

# Operating Manual

SurroundControl 30900/30900-24

## Operating Manual

### RTW SurroundControl 30900/30900-24

Manual Version: 2.2 english  
Issued: 2006-11-28  
Software Version: 02.01.06 (2006-11-09)

© **RTW**

**RADIO-TECHNISCHE WERKSTÄTTEN GmbH & Co. KG**

Fax: +49(0)2 21-7 09 13-32 • Tel.: +49(0)2 21- 7 09 13-33

Elbeallee 19 • 50765 Köln • Germany

P. O. box 71 06 54 • 50746 Köln • Germany

Internet: [www.rtw.de](http://www.rtw.de) • E-Mail: [rtw@rtw.de](mailto:rtw@rtw.de)

WEEE-Reg.-No.: DE 90666819

Category: 9

Device type: These instruments comply with and fall under category 9  
Monitoring and control equipment of Annex 1B of the  
RoHS-Directive 2002/95/EC.

**Note:**

The photos and graphics in this manual are provided to illustrate the functions and displays of the instrument and make the descriptions and instructions more comprehensible. Ongoing product development may result in minor design changes, so that your version of the instrument may look slightly different from the illustrations. This applies in particular to the screen displays.



## Scope of this manual

This operating manual describes features, connection and functionality of the SurroundControl 30900 and the SurroundControl 30900-24.

- Chapter one contains a basic function description of the instrument.
- Chapter two explains the setup of the SurroundControl 30900(-24). This chapter also contains important additional information about safety.
- Chapter three describes all key functions and how to operate the SurroundControl 30900(-24) and the Remote Control 30050.
- Chapter four describes the setting menus
- Informations about software updates can be found in chapter five.
- The appendix covers specifications, declarations of conformity and notes about licenses.

### Symbols used in this manual:

SurroundControl 30900(-24):

This term indicates that all following informations cover the SurroundControl 30900 unit series as well as the SurroundControl 30900-24 unit series.



This symbol draws your attention to related topics.



Press the button/key or select the menu file card ...



Warning! (see below for description)



Attention! (see below for description)



Functional earth terminal (see below for description)



Protective earth terminal (see below for description)

## Safety symbols

The following symbols may be marked on the panels or covers of equipment or modules and are used in this manual:



**WARNING!** - This symbol alerts you to a potentially hazardous condition, such as the presence of dangerous voltage that could pose a risk of electrical shock. Refer to the accompanying Warning Label or Tag, and exercise extreme caution.



**ATTENTION!** - This symbol alerts you to important operating considerations or a potential operating condition that could damage equipment. If you see this marked on equipment, consult the User's manual or Operator manual for precautionary instructions.



**FUNCTIONAL EARTH TERMINAL** - This symbol marks a terminal that is electrically connected to a reference point and is intended to be earthed for any functional purpose other than safety.



**PROTECTIVE EARTH TERMINAL** - This symbol marks a terminal that is bonded to conductive parts of the instrument. Confirm that this terminal is connected to an external protective earthing system.

Please note the safety informations in section 2.2 and the hints in every chapter.

# Index of Contents

Scope of this manual .....	3
Safety symbols .....	3
<b>Index of Contents .....</b>	<b>4</b>
<b>1 Introduction .....</b>	<b>9</b>
<b>1.1 The SurroundControl 30900(-24) and its Components .....</b>	<b>9</b>
<b>1.2 Description .....</b>	<b>10</b>
Signal Interfaces: .....	10
Control Interfaces and Other Ports .....	10
<b>1.3 Product Designations .....</b>	<b>10</b>
<b>1.4 Screen Display and Controls .....</b>	<b>11</b>
<b>1.5 Functions .....</b>	<b>12</b>
Metering Functions .....	12
Monitoring Controller Functions .....	12
<b>1.6 Metering Instruments .....</b>	<b>13</b>
1.6.1 The Peak Program Meter Instrument (PPM) .....	13
1.6.2 The Surround Sound Analyzer Instrument (SSA) .....	15
1.6.3 The Audio Vectorscope Instrument (VSC) .....	18
1.6.4 The Correlator Instrument (Cor) .....	20
1.6.5 The 1/3 Octave RTA Instrument (RTA 1/3) .....	22
1.6.6 The 1/6 Octave RTA Instrument (RTA 1/6) .....	23
1.6.7 The (Two-Channel) Downmix Meter Instrument (Downmix) .....	24
1.6.8 The AES/EBU Status Monitor instrument (AES/EBU) .....	25
1.6.9 The Dialnorm Instrument (DIALNORM) .....	26
<b>1.7 Monitoring Controller Instruments .....</b>	<b>28</b>
1.7.1 The Monitoring Instrument .....	28
The CAL Instrument (sub-function of the Monitoring instrument) .....	29
1.7.2 The Remote Control 30050 .....	30
<b>2 Getting Started .....</b>	<b>33</b>
<b>2.1 Installation and Setup .....</b>	<b>33</b>
<b>2.2 Safety Information .....</b>	<b>34</b>
<b>2.3 Connections .....</b>	<b>35</b>
2.3.1 Power Supply .....	36
2.3.2 Remote Connector .....	36
2.3.3 VGA-OUT Monitor Connector .....	36
2.3.4 LAN Connector .....	37
2.3.5 USB A Connector .....	37
2.3.6 USB B Connector .....	37
2.3.7 XLR Connector .....	37
2.3.8 Meter IN Analog Connector .....	38
2.3.9 Monitoring IN 1 Analog Connector .....	39
2.3.10 Monitoring IN 2 Analog Connector .....	40
2.3.11 Monitoring IN 3 Digital Connector .....	41
2.3.12 Monitoring IN 4 Digital Connector .....	42
2.3.13 Monitoring Analog OUT Connector .....	43
2.3.14 Monitoring Digital OUT Connector .....	44
2.3.15 Aux IN/OUT Ref Sync IN Connector .....	45
2.3.16 GP IO Connector (General-purpose Input/Output) .....	46

<b>2.4 Presets</b> .....	<b>47</b>
2.4.1 Preset F 15: 5.1 DA .....	47
2.4.2 Preset F 16: 5.1 DD .....	47
2.4.3 Preset F 17: 5.1 AA .....	48
2.4.4 Preset F 18: 5.1 AD .....	48
2.4.5 Preset F 19: 5.1 DA2 .....	48
2.4.6 Preset F 20: 5.1 DD2 .....	49
2.4.7 Preset F 21: 7.1 DA .....	49
2.4.8 Note for Audio Signal Wiring .....	50
<b>3 Operation</b> .....	<b>51</b>
<b>3.1 Operating Options</b> .....	<b>51</b>
<b>3.2 The Control Keys and the Toolbar</b> .....	<b>52</b>
<b>3.3 Toolbar Modes: Function Select and Instrument Select</b> .....	<b>53</b>
3.3.1 Function Select .....	53
3.3.2 Instrument Select .....	53
<b>3.4 Functions of the PPM Instrument</b> .....	<b>54</b>
3.4.1 Memory .....	54
3.4.2 Reset .....	54
3.4.3 Gain .....	55
3.4.4 PHold .....	55
3.4.5 SPL .....	55
3.4.6 Meter In .....	55
<b>3.5 Functions of the SSA Instrument</b> .....	<b>56</b>
3.5.1 PSI .....	56
3.5.2 DMI .....	56
3.5.3 LPF .....	56
<b>3.6 Functions of the VSC Instrument</b> .....	<b>57</b>
3.6.1 Input Select (Sur) – L - R (2Ch) .....	58
3.6.2 Mode 2Ch/4Ch (Sur) – Lext - Rext (2Ch) .....	58
3.6.3 Display .....	58
3.6.4 Corr .....	58
3.6.5 Grid .....	59
<b>3.7 Functions of the COR Instrument</b> .....	<b>60</b>
3.7.1 LPF .....	61
<b>3.8 Functions of the RTA 1/3 and RTA 1/6 Instruments</b> .....	<b>62</b>
3.8.1 Input Select .....	63
3.8.2 Display Hold .....	63
3.8.3 < Cur and Cur > .....	63
3.8.4 Cur Ref .....	64
3.8.5 Ref + and Ref – .....	64
3.8.6 Scale .....	64
3.8.7 Range .....	64
3.8.8 Weighting .....	64
3.8.9 RMS .....	64
3.8.10 Peak .....	65
3.8.11 PHold .....	65
3.8.12 PHold Reset .....	65
<b>3.9 Functions of the Downmix Instrument</b> .....	<b>66</b>
3.9.1 Memory .....	66
3.9.2 Reset .....	66
3.9.3 PHold .....	66
3.9.4 SPL .....	66
3.9.5 Display .....	67
3.9.6 Meter/Directout .....	67
3.9.7 Grid .....	67

<b>3.10 Functions of the Monitoring Instrument .....</b>	<b>68</b>
3.10.1 Mono Mode .....	68
3.10.2 DIM Level.....	69
3.10.3 LF Boost.....	69
3.10.4 Sur -3 dB .....	69
3.10.5 Vol Sens .....	69
3.10.6 Ch Setting .....	70
3.10.7 Cal.....	70
3.10.8 Level .....	70
<b>3.11 Functions of the Cal Instrument.....</b>	<b>71</b>
3.11.1 Trim .....	71
3.11.2 Delay .....	72
3.11.3 Delay Unit .....	72
3.11.4 Next Cha .....	73
3.11.5 All.....	73
3.11.6 Signal Select.....	73
3.11.7 Close .....	73
3.11.8 RTA .....	73
3.11.9 SPL Meter .....	74
3.11.10 Ref SPL Dec .....	75
3.11.11 Ref SPL.....	75
3.11.12 Ref SPL Inc.....	75
3.11.13 Close .....	75
<b>3.12 The Cal Instrument's Signal Select Functions (Monitoring) .....</b>	<b>76</b>
3.12.1 P-Noise .....	78
3.12.2 LF-Test .....	79
3.12.3 Sine .....	81
<b>3.13 Functions of the AES/EBU Instrument .....</b>	<b>82</b>
3.13.1 Next Channel and Previous Channel .....	82
3.13.2 Ch Status .....	82
3.13.4 Binary .....	83
3.13.3 HW Status .....	83
3.13.5 Audio.....	84
<b>3.14 Functions of the Dialnorm Instrument .....</b>	<b>85</b>
3.14.1 Start .....	85
3.14.2 Stop .....	85
3.14.3 Pause .....	85
3.14.4 Reset.....	85
3.14.5 Channel Select.....	86
<b>3.15 The Controls of the Remote Control 30050 Unit .....</b>	<b>87</b>
3.15.1 The Monitoring Sound Pressure Level Display (SPL) .....	87
3.15.2 The Function Keys .....	88
3.15.3 The Control Keys and the Select Key .....	88
3.15.4 Function Selector for the Channel Keys .....	89
3.15.5 The Channel Keys .....	90
3.15.6 The 2C Key .....	90
3.15.7 The EX Key.....	90
3.15.8 The CS Channel Key .....	91
3.15.9 The LF Channel Key .....	91
3.15.10 The Mono Key.....	91
3.15.11 The Volume Dial .....	91
3.15.12 The Input Key (input switcher) .....	92
3.15.13 The DIM Key .....	92
3.15.14 The Output Key (output switcher) .....	92

<b>3.16 Connecting several Remote Control 30050</b> .....	<b>93</b>
3.16.1 Addressing .....	93
3.16.2 Operating priority .....	94
<b>4 Menus</b> .....	<b>95</b>
<b>4.1 Introduction</b> .....	<b>95</b>
<b>4.2 Settings – Basic Principles</b> .....	<b>97</b>
Routing in the Global Settings .....	98
Special case: Local routing settings in the Instrument Settings .....	98
The surround format setting .....	98
The Downmix Matrix .....	98
Downmix in 6.1 and 7.1 Format .....	99
The Lext/Rext channels .....	99
The LO/RO channels .....	99
Routing configuration .....	99
<b>4.3 Menu Structure Reference</b> .....	<b>100</b>
<b>4.4 The Instrument Settings Menu</b> .....	<b>102</b>
4.4.1 General Presets .....	103
4.4.2 Peakmeter .....	104
4.4.3 Two Channel Downmix .....	106
4.4.4 Extern .....	108
4.4.5 Vectorscope .....	109
4.4.6 RTA .....	110
4.4.7 Local Input/Output Routing .....	112
<b>4.5 The General Settings Menu</b> .....	<b>117</b>
<b>4.6 The Input/Output Routing Menu</b> .....	<b>119</b>
<b>4.7 The Audio System Menu</b> .....	<b>124</b>
<b>4.8 The Reference Levels Menu</b> .....	<b>128</b>
<b>4.9 The Over Indicator Menu</b> .....	<b>130</b>
<b>4.10 The Communication Menu</b> .....	<b>131</b>
<b>4.11 The Alarm Configuration Menu</b> .....	<b>132</b>
4.11.1 Alarms General Settings .....	132
4.11.2 Alarms Threshold Settings .....	134
4.11.3 Alarms Timing .....	135
4.11.4 Alarm-Event Type Selection .....	135
<b>4.12 The Key Settings Menu</b> .....	<b>137</b>
4.12.1 Preset Recall Mode .....	137
4.12.2 Display Mode for External Monitoring .....	138
4.12.3 Display Mode for Downmix Monitoring .....	138
4.12.4 Disable Keys/GPI .....	139
4.12.5 Function Mode for Monitoring Channel Keys .....	140
<b>4.13 Channel Group Settings in Channel mode Surround</b> .....	<b>141</b>
<b>4.14 Channel Group Settings in Channel mode 2 Channel Stereo</b> .....	<b>149</b>
<b>5 Software Update</b> .....	<b>155</b>
<b>5.1 General</b> .....	<b>155</b>
<b>5.2 Proceeding the export of the User Presets</b> .....	<b>156</b>
<b>5.3 Proceeding a Software Update</b> .....	<b>160</b>
<b>5.4 Proceeding the import of the User Presets</b> .....	<b>165</b>
<b>6 Mechanical Layout</b> .....	<b>169</b>
<b>6.1 Dimensions</b> .....	<b>169</b>
<b>6.2 Configuration</b> .....	<b>170</b>
<b>6.3 Accessories</b> .....	<b>170</b>

<b>Appendix A: Specifications .....</b>	<b>171</b>
<b>Appendix B: Declaration of Conformity .....</b>	<b>177</b>
<b>Appendix C: Licenses .....</b>	<b>179</b>
<b>Information on the licenses that apply to the software supplied     with the product .....</b>	<b>179</b>
<b>Appendix D: GNU GENERAL PUBLIC LICENSE.....</b>	<b>181</b>



# 1 Introduction

## 1.1 The SurroundControl 30900(-24) and its Components

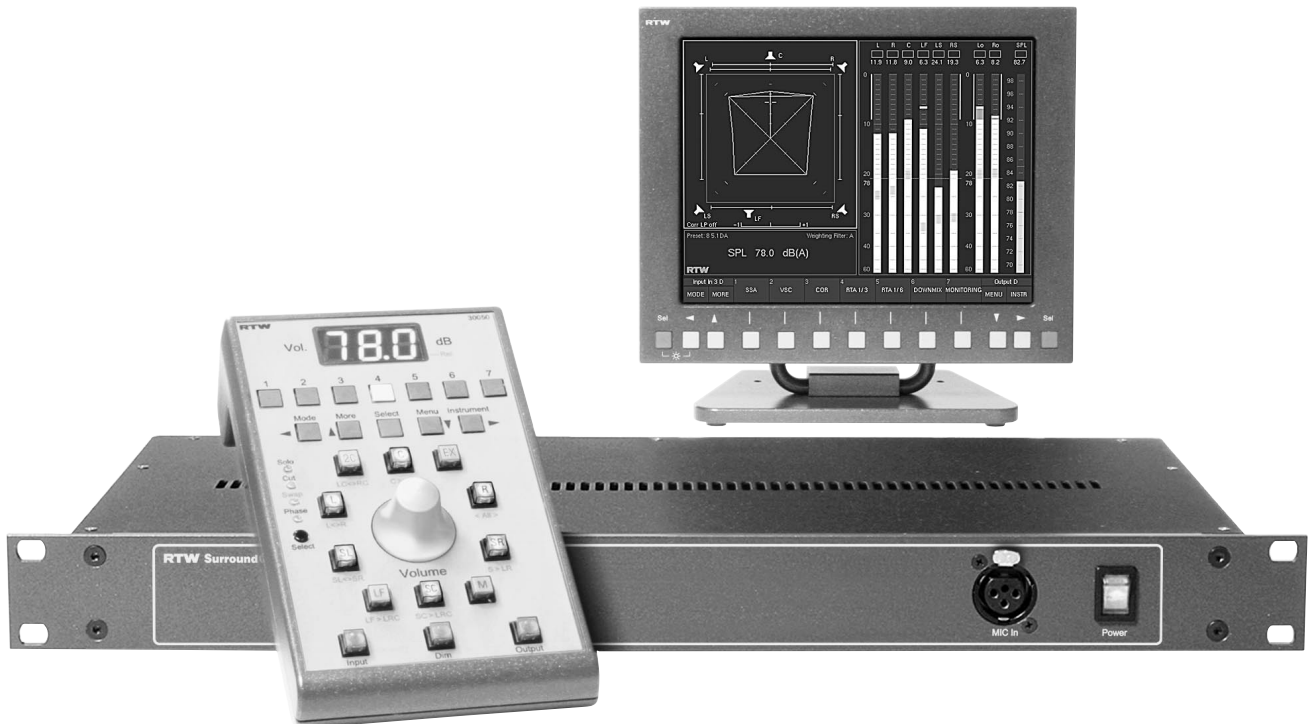

Fig. 1-1: The SurroundControl 30900(-24) with Remote Control 30050 and the optional Remote Display 30010 (not included in standard package)



Fig. 1-2: Remote Control 30050

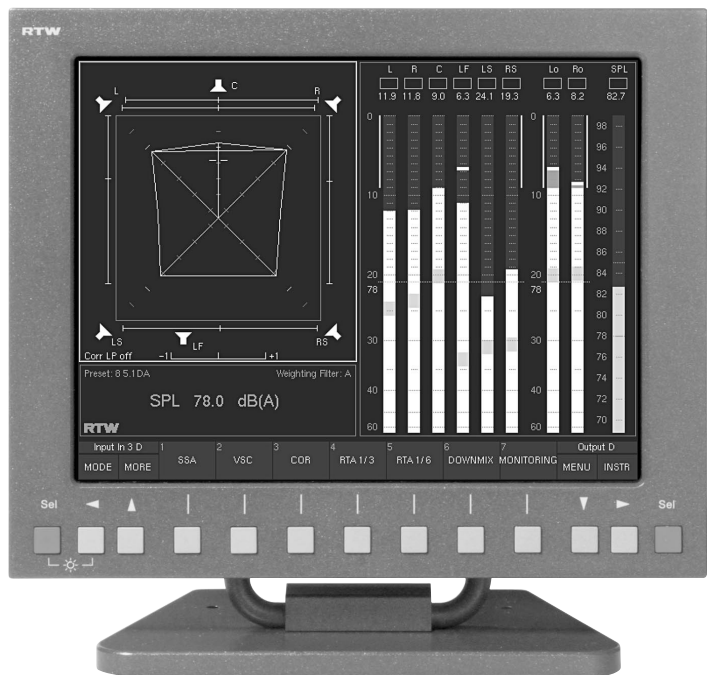

Fig. 1-3: Remote Display 30010 (optional – not included)

## 1.2 Description

The SurroundControl 30900(-24) is an 8-channel monitoring controller with level metering and signal analysis functions for comprehensive metering and monitoring of your audio programmes. The combination of metering and monitoring controller functions in a single unit makes the SurroundControl 30900(-24) ideal for surround sound productions. Additional features like the integrated multi-channel test signal generator and the connection for a calibration microphone extend the SurroundControl's scope to calibration and general maintenance of your entire studio monitoring setup.

The electronics are installed in a 19"/1U housing. The instrument is operated with Remote Control 30050 remote control units. Up to three remote control units can be connected simultaneously. To view the instrument's output you need an external CRT or TFT display, such as the optional 8.4" Remote Display 30010 from RTW (see Fig. 1-3), the colour and design of which match the main SurroundControl 30900(-24) unit.

The SurroundControl 30900(-24) has the following signal and control interfaces:

### Signal Interfaces:

- Three analog 8-channel inputs (Monitoring In 1 analog, Monitoring In 2 analog, Meter In analog)
- Two digital 8-channel (4 x 2) AES/EBU inputs (Monitoring In 3 digital, Monitoring In 4 digital)
- One analog 8-channel output (Monitoring analog Out)
- Sampling rate 44.1, 48 or 96 kHz selectable in analog mode without digital signal present or else up to 96 kHz according to the digital input or reference signal
- One digital 8-channel (4 x 2) AES/EBU output (Monitoring digital Out)
- Sampling rate according to the ref sync signal or the selected internal sampling rate.
- Separate AES/EBU Ref Sync input

In addition to this the unit also has an analog mic input. This is used in for the SPL meter as the input for the calibration microphone (additional XLR-F input on the front panel).

### Control Interfaces and Other Ports

- VGA output (640 x 480, 256 colours) for connection of a standard TFT or CRT monitor or RTW's optional 8.4" Remote Display 30010, which features control keys that can communicate directly with the SurroundControl 30900(-24) via the VGA port.
- Ethernet network connector
- USB 1.1 connector for an optional mouse
- GP IO interface (16 inputs, 8 outputs)
- RS-422 port for the Remote Control 30050 (required)

## 1.3 Product Designations

SurroundControl 30900: 19"/1U main unit up to +18 dBu maximum level  
SurroundControl 30900-24: 19"/1U main unit up to +24 dBu maximum level  
Remote Control 30050: control unit  
Remote Display 30010: TFT monitor with integrated function and control keys

## 1.4 Screen Display and Controls

In this manual the SurroundControl's display functions are referred to as "instruments". The instruments and other functions are displayed in up to four windows. Usually, all four windows are visible, but sometimes larger instruments can cover other instruments. The sizes and positions of the instruments on the screen are fixed and cannot be adjusted by the user.

- **Window 1: Toolbar**

The Toolbar is always visible. It contains the controls for all the instruments' functions and displays information on current operating modes. You can control the functions in three ways: With the Remote Control 30050, with the keys on the Remote Display 30010 or with an optional computer mouse.

- **Window 2: Peak Program Meter**

The right half of the screen is normally occupied by the PPM display. It is only covered when the RTA 1/6 instrument is activated.

- **Window 3: Selected Instruments**

The left part of the screen is used to display the instruments selected with the buttons in the Toolbar, the function keys on the Remote Control 30050 or an optional mouse.

- **Window 4: Status Box**

This window is used to display current status information, messages etc. Some of the instruments cover the Status Box when they are activated.

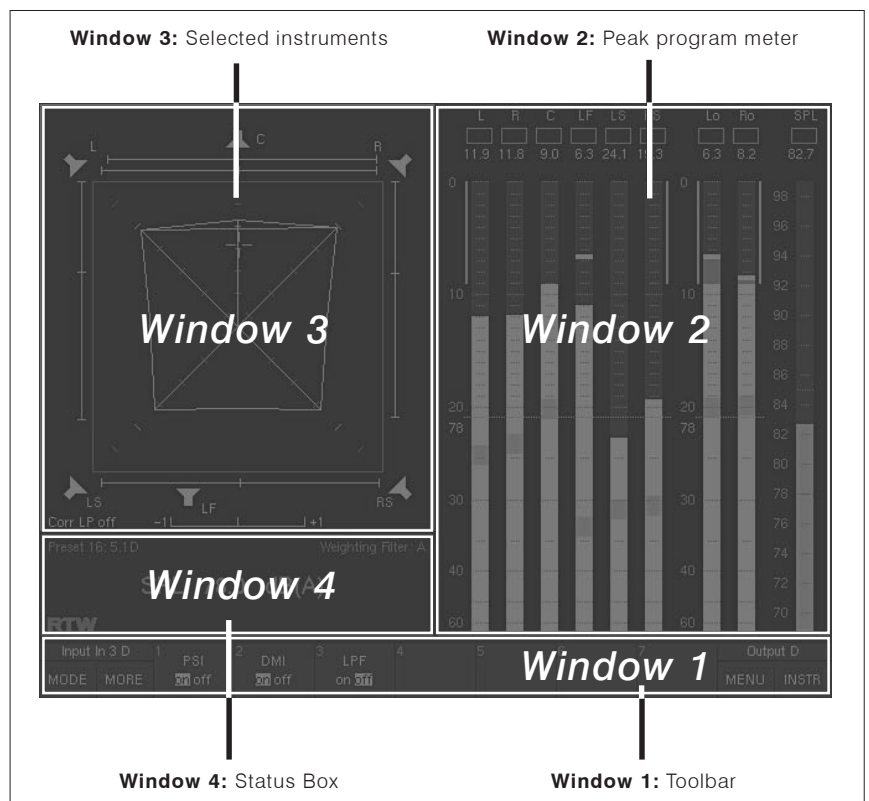



Fig. 1-4: The four screen display windows



See Chapter 1.6 for full details 

## 1.5 Functions

The SurroundControl 30900(-24) has two main function categories: the Metering functions and the Monitoring Controller functions (see below). All the metering and monitoring controller functions can be operated with the Remote Control 30050 (see figure beside). The metering functions can also be controlled with the keys on the optional Remote Display 30010 or with an optional computer mouse.

### Metering Functions

These functions include the peakmeter and all other functions for signal analysis and monitor calibration:

- Multi-format PPM for all common standards, analog and/or digital, with RMS/SPL display, selectable track layout, for surround formats 5.1, (3/2), 6.1 (3/3), 7.1 (5/2), 2/0, SPL calibration supported with display of the resulting SPL
- 2-Channel PPM in 2 Channel Stereo mode for all common standards, analog and/or digital, with RMS/SPL display, SPL calibration supported with display of the resulting SPL
- Multi-correlator for surround formats 5.1, 6.1, 7.1 (COR)
- Surround sound analyzer (SSA)
- Audio vectorscope with 2 and 4 channel mode (VSC)
- 1/3 octave real time analyzer (RTA 1/3)
- 1/6 octave real-time-analyzer (RTA 1/6)
- SPL Meter
- AES/EBU status monitor
- Dialnorm meter
- Downmix matrix with downmix meter (level, correlation meter, vectorscope)
- Multi-channel test signal generator
- Alarm functions

See Chapter 1.7 for full details 

### Monitoring Controller Functions

The Monitoring Controller consists of an 8-channel level control and a routing matrix for executing the various functions like Solo, Cut, Channel Swap and Phase Reverse for each channel.

- Supports surround formats 5.1, 6.1 and 7.1
- 8-channel digital volume control with preset function
- Calibratable volume display
- Channel functions:
  - Solo
  - Cut
  - Channel Swap (individual channels and all channels)
  - Rear-to-Front
  - Phase Reverse
  - Mono (several modes)
  - Level Trim for every surround monitoring output, analog and digital
  - adjustable Delay for every surround monitoring output, analog and digital
- Downmix outputs DL<sub>0</sub>/DR<sub>0</sub> (Direct Downmix Out, independent of volume controls) and VL<sub>0</sub>/VR<sub>0</sub> VOL for listening via volume controls
- DIM key with adjustable dimming (attenuation)

## 1.6 Metering Instruments

See Chapter 3.4 for operating instructions



### 1.6.1 The Peak Program Meter Instrument (PPM)

Window 2 in the screen display is permanently assigned to the peakmeter groups and is always displayed in the right-hand window, only the RTA 1/6 instrument overwrites the PPM instrument. The display of the Peakmeter and according to that the display of other instruments depends on the Channel Mode selected with the combo box in the Peakmeter menu.

#### • Surround Mode:

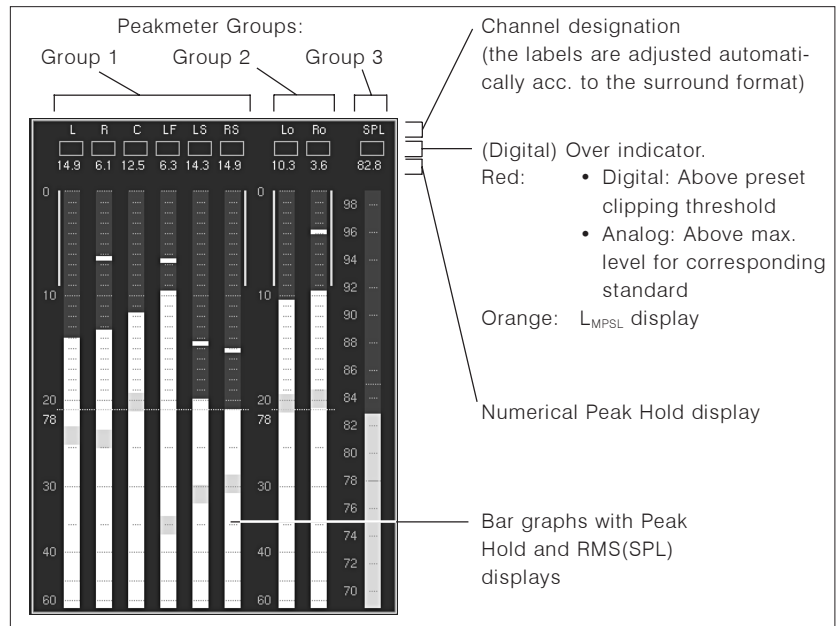

Fig. 1-5: Display elements of the Peak Program Meter instrument (PPM) in Surround mode

See Chapter 4.2 and 4.13 for description of settings



The peakmeter display in surround mode consists of up to three peakmeter groups (channel groups). Each group can have different domains, standards and settings. Peakmeter group 1 dictates the surround format for the entire unit.

#### Selecting the Surround formats:

- with the buttons/keys:
  - MENU → button Edit selected preset → Menu Peakmeter → select the Surround option in Combo box Channel Mode → button Channel Group 1 → Combo box Mode Select → select the surround format
- optional with the mouse:
  - Right click onto the Peakmeter window (Window 2) → click Combo box Channel Mode and select the Surround option → left click button Channel Group 1 → click combo box Mode Select → select the surround format

By the use of the Position combo boxes in the Peakmeter menu (see Chapter 4.4.2) the displays of the groups can be turned on and off and their order can be selected as required. The widths of the display bars are adjusted automatically by the software. Every peakmeter group has a numerical display, an Over indicator and a Peak Hold function. The RMS/SPL display can be switched on.

• **2 Channel Stereo Mode:**

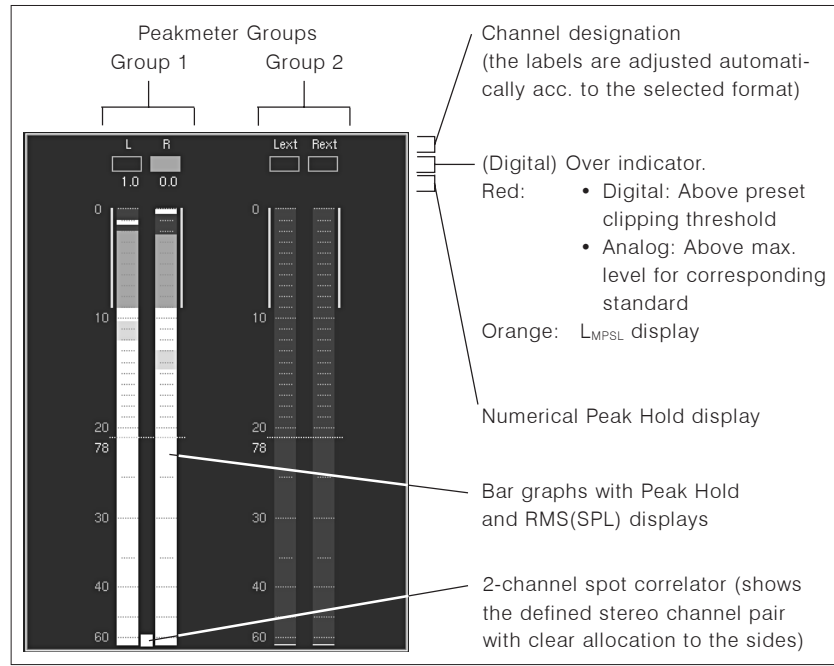

Fig. 1-6: Display elements of the Peak Program Meter instrument (PPM) in 2 Channel Stereo mode

See Chapter 4.2 and 4.14 for description of settings



The peakmeter display consists of up to two peakmeter groups (channel groups). Peakmeter group 1 dictates the 2 Channel Stereo format for the entire unit and displays a stereo channel pair with the dedicated channels L and R. This peakmeter (Channel Group 1) is labelled with 2 Ch Stereo + SpCor (2-Channel stereo with spot correlator, see Chapter 4.14). The Channel Group 2 can be used for the display of an external stereo signal with the channels L<sub>ext</sub> and R<sub>ext</sub>. Each group can have different domains, standards and settings.

**Selecting the 2 Channel Stereo format:**

→ MENU → button Edit selected preset → Menu Peakmeter → select the 2 Channel Stereo option in Combo box Channel Mode → button Channel Group 1 → the combo box Mode Select displays 2 Ch Stereo + SpCor

By the use of the Position combo boxes in the Peakmeter menu the displays of the groups can be turned on and off and their order can be selected. The widths of the display bars are adjusted automatically by the software. Every peakmeter group has a numerical display, an Over indicator and a Peak Hold function. The RMS/SPL display can be switched on.

See Chapter 3.5 for operating instructions

## 1.6.2 The Surround Sound Analyzer Instrument (SSA)

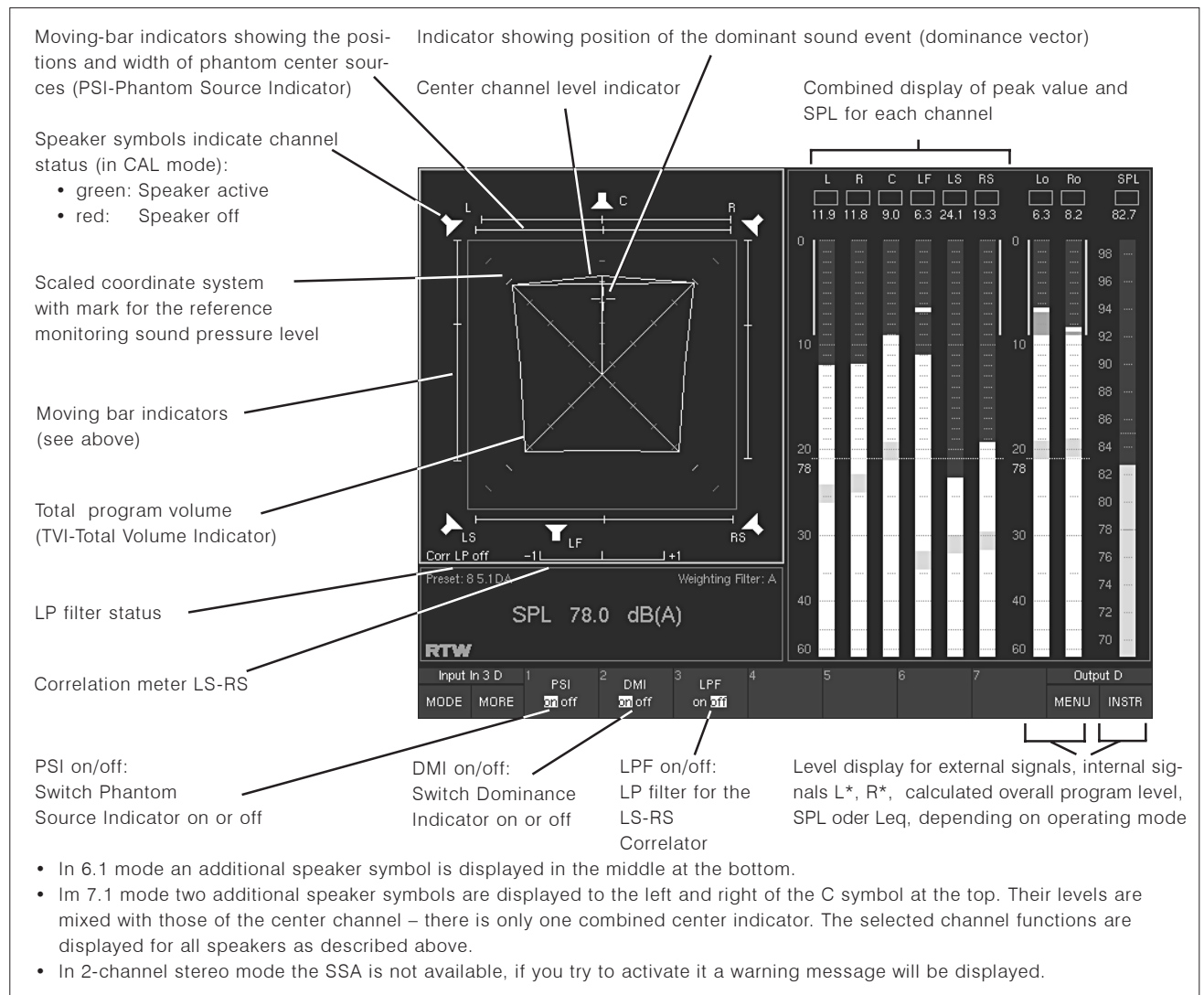

Fig. 1-7: Surround Sound Analyzer instrument displays (SSA)

The SSA instrument is **only** available in Surround mode!



The Surround Sound Analyzer combines displays of all the following information for surround format signals:

- Balance between front and surround channels
- Balance of the L-C-R front channels
- Front, side and rear phantom sources
- Dominant sound events
- Calibratable coordinate system (SPL – volume level)
- Overall volume of the surround signal (indicated by the area of the polygon)
- Phase correlation of the surround channels for low frequencies



The Surround Sound Analyzer displays a correctly-scaled graphical representation of the relative volumes in the surround sound field. The interaction of levels (volume or sound pressure level) and the correlation of all channels in the production of the overall surround sound is displayed graphically, providing a very clear overview. The graphical display has been carefully designed so that the dynamic behaviour of all display elements corresponds to the subjective listening impression, enabling you to see the balance of your surround programme intuitively and at a glance. The display in the Surround Sound Analyzer can be set to correspond to the volume or the reference sound pressure level by calibrating the SurroundControl 30900(-24) and your studio monitoring equipment accordingly. The axes of the 45° coordinate system use a dB volume level or dB-SPL scale and have a reference mark that is also displayed in the volume level and SPL displays in the peak program meters.

### Graphical display of the overall volume

The Surround Sound Analyzer displays the relative levels of the surround signals with lines that form a polygon. This makes it possible to provide a clear, at-a-glance display of several parameters simultaneously. The polygon is generated by combining the displayed level values on the scales of the 45° coordinate system. If you feed noise signals with exactly the same levels to all channels you will get a square, the area of which corresponds to the overall volume. The relative distribution in the four quadrants corresponds to the volume distribution in the surround field. In addition to this the phase correlation and the positions of possible phantom sources are also displayed.

See Fig. 1-8, No. 1  
(on next page)



### The Front Center Channel

The balance between the center channel and the L and R front channels is critical for all surround sound productions. The center channel is displayed with its own pair of lines to enable you to see volume differences between the Center and L and R channels very clearly. An additional indicator shows the base width of the center sound source.

See Fig. 1-8, No. 4 - 5  
(on next page)



### The Center Surround Channel

In 6.1 mode the levels of the additional center surround channel are combined with those of the LS and RS surround channels. Currently, there is no separate center surround indicator.

In 7.1 mode the levels of the additional front channels are combined with the front center channel. There is thus only one combined front center indicator.

### Surround Channel Correlation Display

The “envelopment effect” of the surround channels can be evaluated with a separate display that shows the correlation of surround channels LS and RS for broadband or for low frequencies only. Ideally, the low-frequency signal components (reverberation) should be decorrelated as far as possible.

See description in  
Chapter 1.6.4



The SurroundControl 30900(-24) also includes an instrument called the 10-fold Multi-Correlator (COR) with which you can check the correlation of all other possible channel pairs.



## Volume-Referenced Level Metering

Volume-referenced level metering has now been generally recommended for some time as the best method for adjusting the levels of multi-channel programmes. The SurroundControl 30900(-24) allows you to adjust your levels on the basis of volume against a defined reference sound pressure level. To do this you calibrate the components in the studio's transmission chain to a reference monitoring sound pressure level (e. g. 85 dB(A)). One of the big advantages of this level control method is that any loudness increase, for example as a result of compression, is automatically included as an absolute value. Volume-based level control makes it much easier to accurately measure and monitor the balance between dialogue, effects and music.

## Examples of the Surround Sound Analyzer's displays

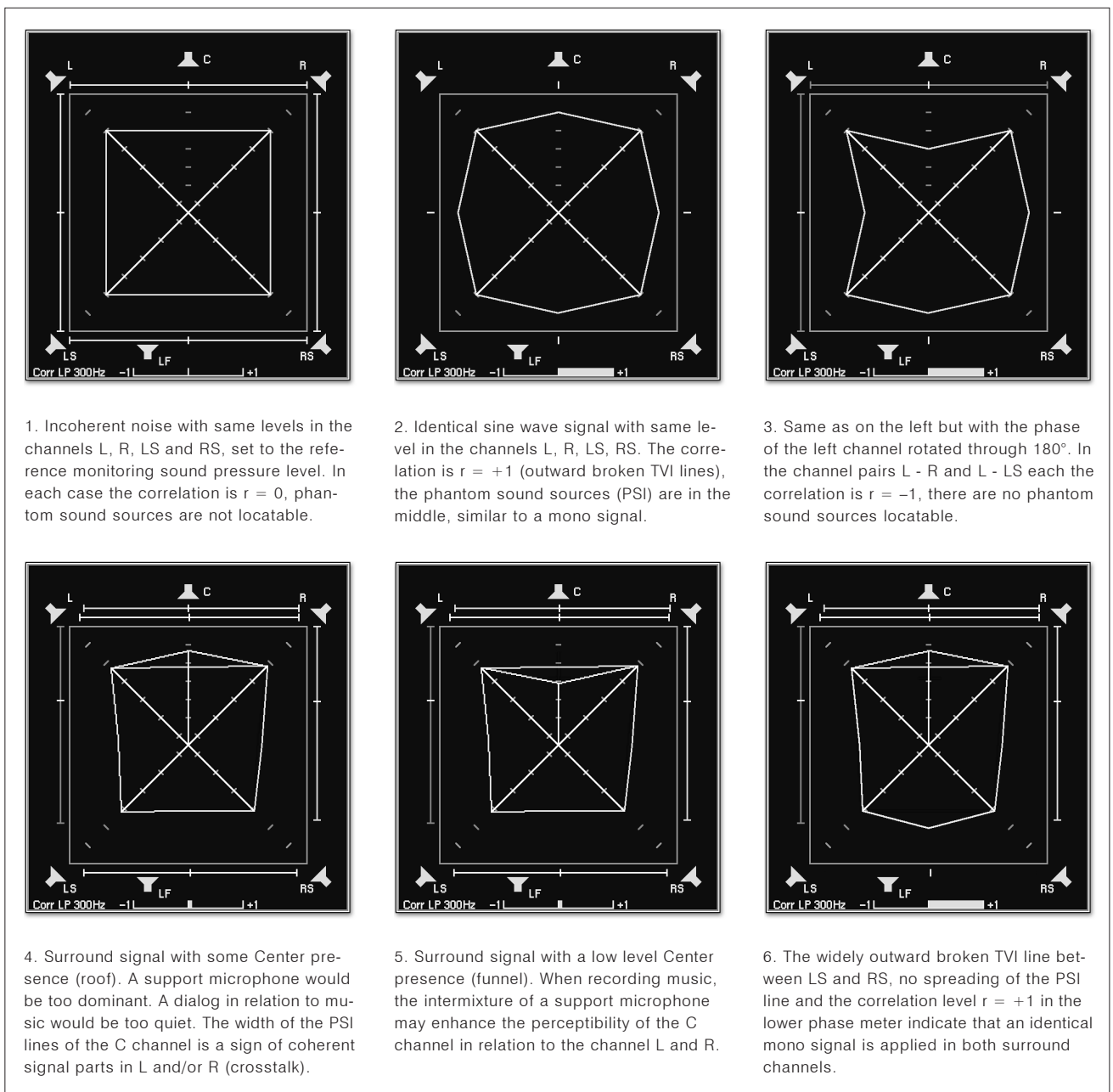

Fig. 1-8: Examples of displays in the Surround Sound Analyzer instrument (SSA), also see: [www.rtw.de/english/special/index.html](http://www.rtw.de/english/special/index.html)

See Chapter 3.6 for operating instructions

### 1.6.3 The Audio Vectorscope Instrument (VSC)

- **Surround Mode:**

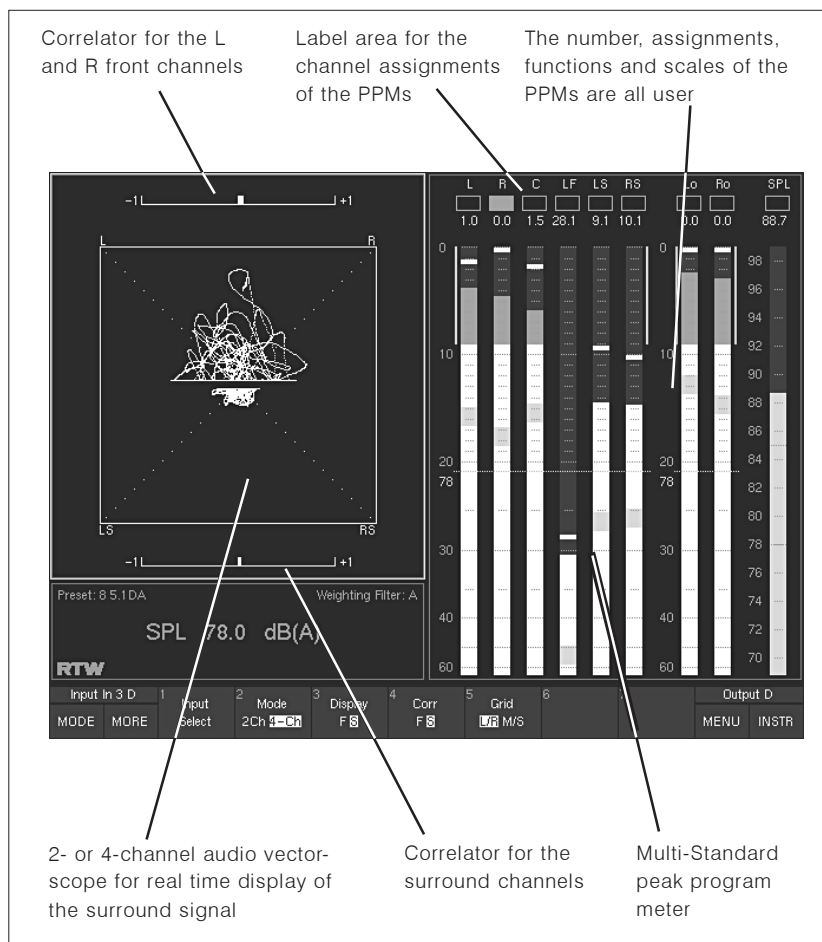

Fig. 1-9: The Audio Vectorscope instrument (VSC) in Surround mode (4-channel mode)

The audio vectorscope display in Surround mode is switchable between 2-channel and 4-channel mode with channel pairs L-R and LS-RS and has separate correlation displays for these channel pairs.

• **2 Channel Stereo Mode:**

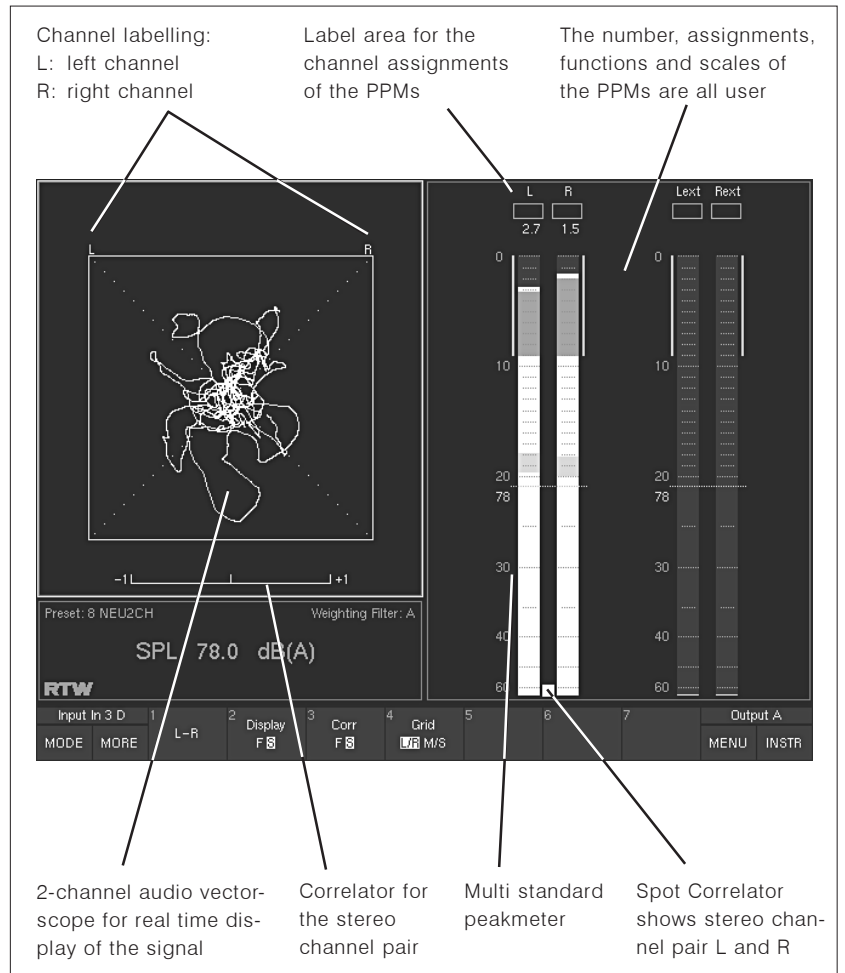

Fig. 1-10: The Audio Vectorscope instrument (VSC) in 2 Channel Stereo mode (L and R channel mode)

Also see Chapter 1.6.1 and Figs. 1-6 and 1-10



In 2 Channel Stereo mode the VSC instrument offers an audio vectorscope display for the Peakmeter - Channel Group 1 and its defined stereo channel pair with the dedicated channels L and R (displayed with a Spot Correlator between the bar graphs of the peakmeter display in window 2, see Chapter 1.6.1 and Figs. 1-6 and 1-10) or for the Peakmeter - Channel Group 2 displaying external stereo signals ( $L_{ext}$  and  $R_{ext}$ ).

See Chapter 3.7 for operating instructions



## 1.6.4 The Correlator Instrument (Cor)

- **Surround Mode:**

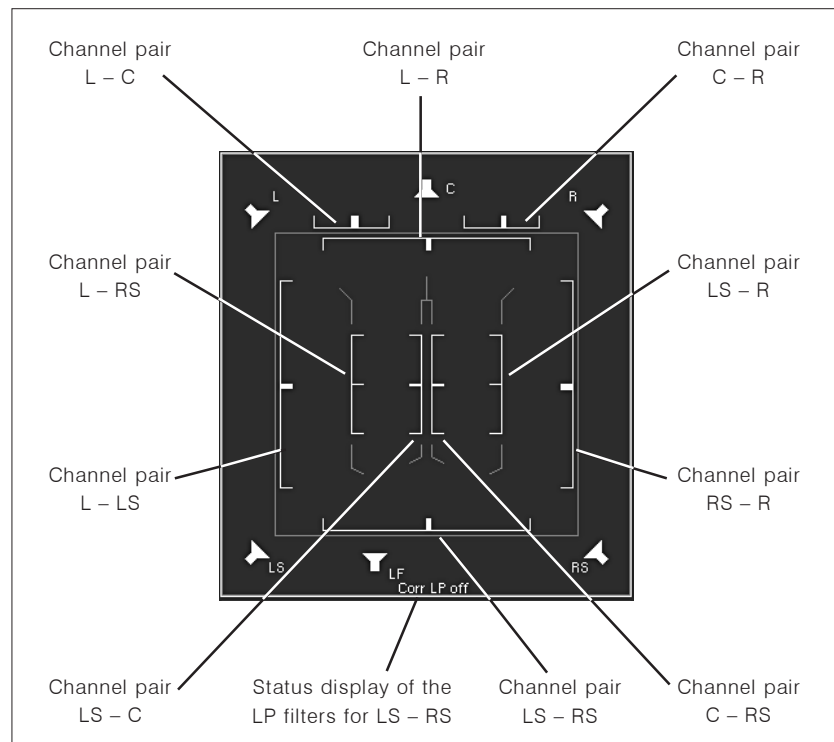

Fig. 1-11: The Correlator instrument (COR) as multi correlator in Surround mode

In 5.1 mode the multi-correlator display shows a clear graphical representation of all 10 channel pairs. You can also activate an optional 300 Hz low pass filter upstream from the instrument to obtain a view of the “surround envelopment” effect. This makes it possible to identify correlations at low frequencies that detract from the sense of envelopment.

In 6.1 mode the system does not yet have a separate display for the surround center channel.

In 7.1 mode the levels of the additional front channels are mixed with those of the front center channel. There is thus only one common front center indicator.

• **2 Channel Stereo Mode:**

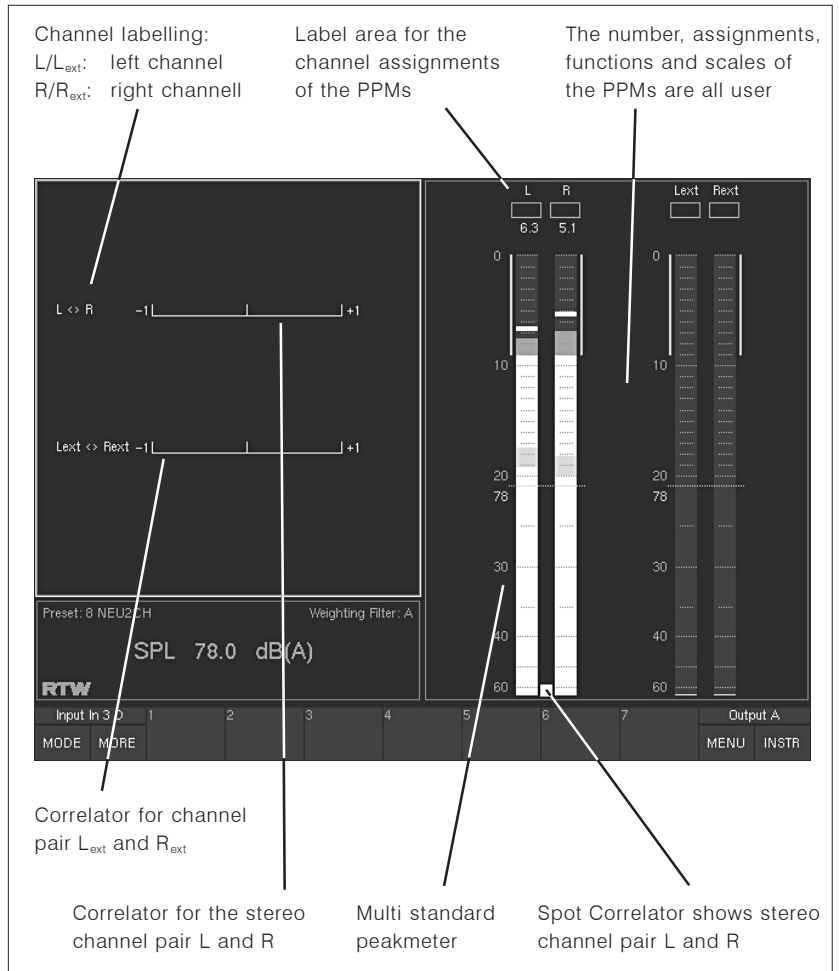

Fig. 1-12: The Correlator instrument (COR) in 2 Channel Stereo mode with defined stereo channel pair and the external channels  $L_{ext}$  and  $R_{ext}$

Also see Chapter 1.6.1 and Figs. 1-6 and 1-12



In 2 Channel Stereo mode the COR instrument offers a correlator display for the defined stereo channel pair with the dedicated channels L and R (displayed with a Spot Correlator between the bar graphs of the peakmeter display in window 2, see Chapter 1.6.1 and Figs. 1-6 and 1-12) and the external stereo signals ( $L_{ext}$  and  $R_{ext}$ ).

See Chapter 3.8 for operating instructions

## 1.6.5 The 1/3 Octave RTA Instrument (RTA 1/3)

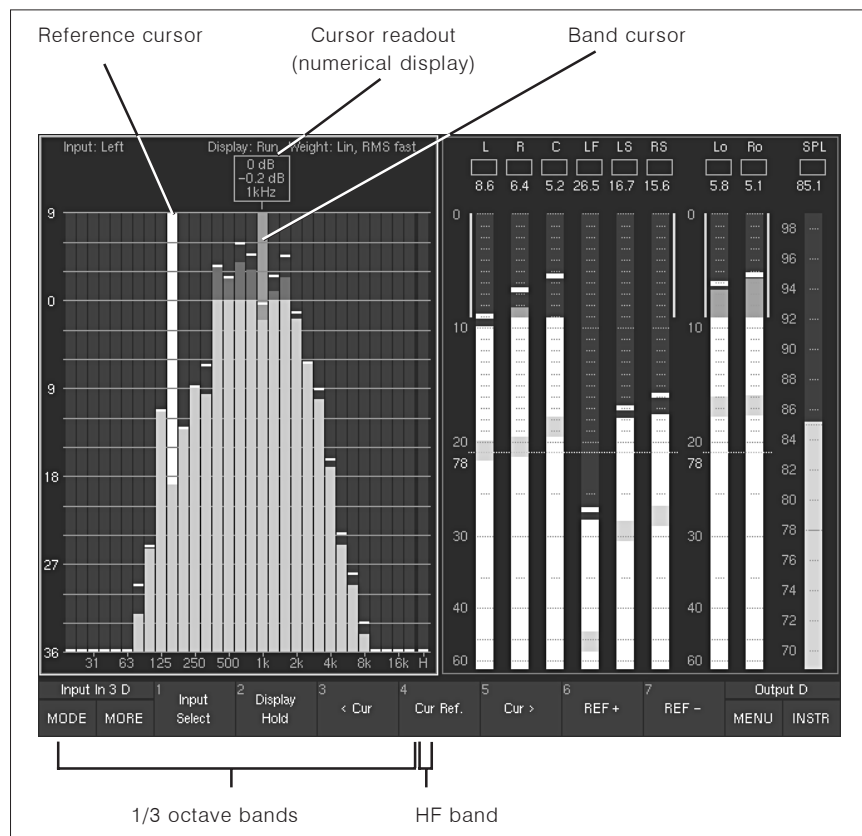

Fig. 1-13: The 1/3 octave RTA instrument (RTA 1/3)

The Real-Time Analyzer displays the spectral distribution of individual channels, the front channel group or the surround channel group.

- RMS integration time pursuant to IEC651
- RMS peak: Rise time 10 ms, fallback time same as a peakmeter
- Additional HF range for signal components above 20 kHz
- Display Hold function for easy evaluation
- Band Cursor with cursor readout to make the values more easily readable
- Reference Cursor function shows the difference between the current band and the reference band

When the RTA 1/3 instrument is activated it covers the Status Box.

See Chapter 3.8 for operating instructions

## 1.6.6 The 1/6 Octave RTA Instrument (RTA 1/6)

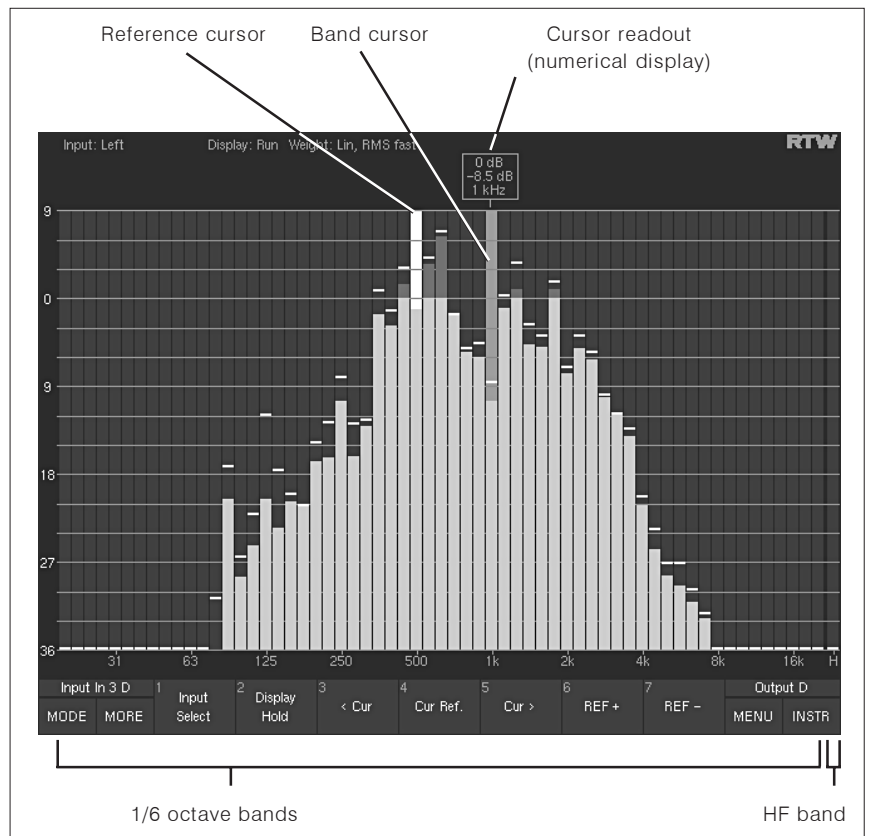

Fig. 1-14: The 1/6 octave RTA instrument (RTA 1/6)

The RTA 1/6 is the only instrument that covers Window 2 with the Peak Program Meter when it is activated. This is necessary because the 1/6 octave analyzer needs more space to be displayed legibly. The functions and controls are identical to those of the RTA 1/3 instrument, with one exception: When you are calibrating the monitoring system you can activate RTA 1/6 from the SPL Meter instrument for evaluation of the signal from the calibration microphone.

See Chapter 3.9 for operating instructions



## 1.6.7 The (Two-Channel) Downmix Meter Instrument (Downmix)

The Downmix instrument is **only** available in Surround mode!

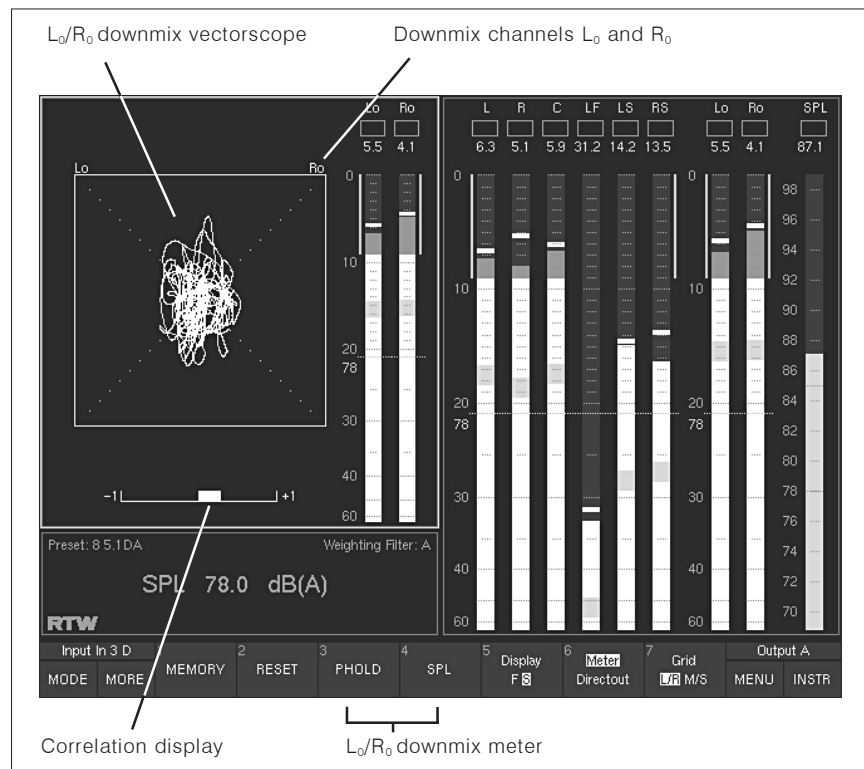

Fig. 1-15: The (Two-Channel) Downmix Meter instrument (DOWNMIX)

The (Two-Channel) Downmix Meter instrument displays the levels and the correlation of the internally-generated two-channel downmix, and it also has a stereo vectorscope function. **The Downmix Meter is only active when the internal downmix matrix is also activated.**

See Chapters 4.6 and 4.4.7 for activating the Downmix Matrix



### Activating the Downmix Matrix:

→ MENU → Menu Input/Output Routing → activate the favoured option button of the Downmix Input Source frame



See Chapter 3.12 for operating instructions



## 1.6.8 The AES/EBU Status Monitor instrument (AES/EBU)

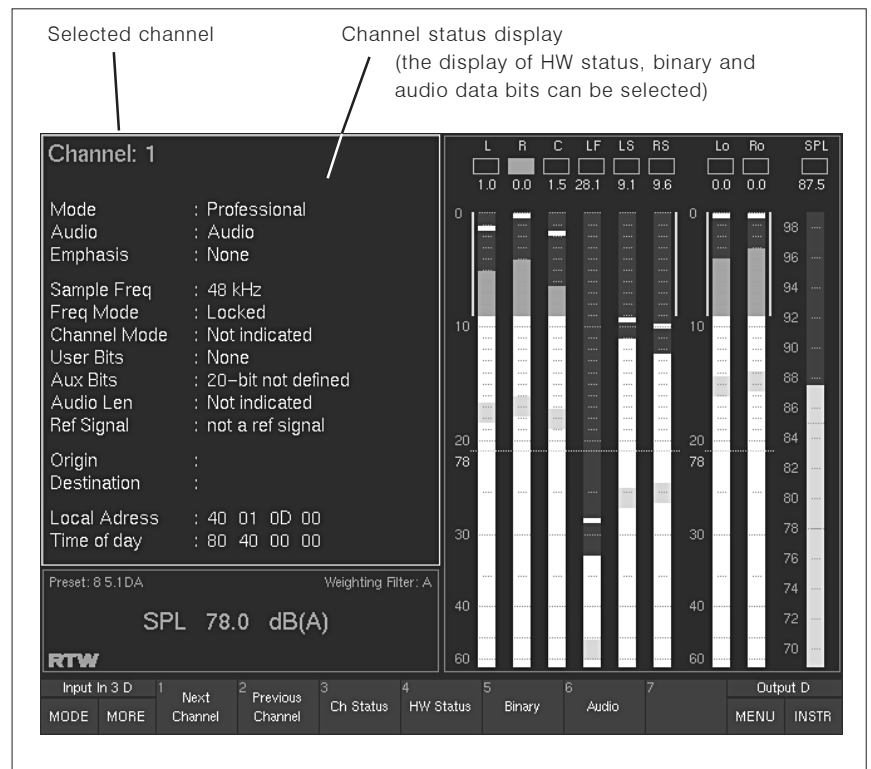

Fig. 1-16: Instrument „AES/EBU-Statusmonitor“ (AES/EBU)

The AES/EBU Status Monitor displays the status bytes from the AES/EBU data stream as plain text. In addition to this it also displays a range of signal status information, including Confidence, Lock, Coding, Parity and Validity. Finally, the AES/EBU Status Monitor displays the audio data bits and their activity, which is useful when you need to determine the word width or identify defective bits in the data stream.

See Chapter 3.13 for operating instructions

## 1.6.9 The Dialnorm Instrument (DIALNORM)

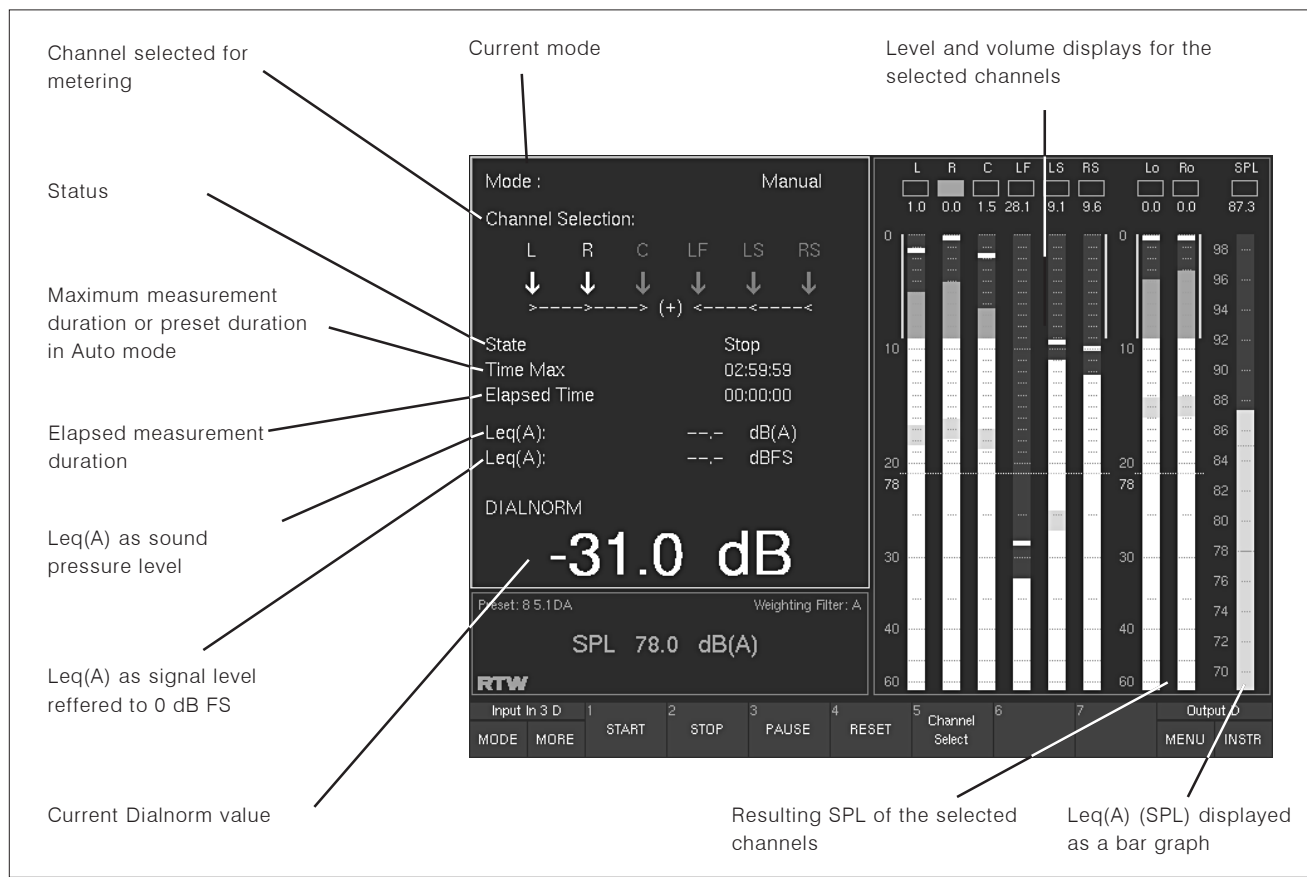

Fig. 1-17: The Dialnorm instrument (DIALNORM)

The term Dialnorm originates from film sound mixing and is an abbreviation for "dialogue normalisation". It refers to the process of normalising the dialogue loudness level, for which a reference value of  $-31$  dB FS is used in surround sound programmes. The idea is that the perceived total loudness of a mixed audio signal may be determined and kept relatively constant for the listener by using the dialogue level (optimised for a balance between good intelligibility and minimisation of annoying excessive dialogue volume levels) with its fixed loudness ratio in relation to music and sound effects as a reference. The ATSC standards A/53 and A/52 specify the transmission of the Dialnorm parameter as part of the meta data in multi-channel sound programmes.

The Dialnorm value is determined with a method used in noise pollution measurement, in which one measures Leq(A), the energy-equivalent A-weighted sound pressure level as defined in IEC 60804. The Dialnorm system uses a modified version of this standard. Instead of using the sound pressure level with a value of  $20 \mu\text{Pa}$  as a reference, Dialnorm measures the electrical signal level with reference to 0 dB FS. This Dialnorm value with 0 dB FS as a reference corresponds to the measured Leq(A) value, using a lower

threshold value of  $-31$  dB FS. In the decoder, Dialnorm values above  $-31$  dB FS lead to a level reduction of the total audio signal by a value of  $(31 \text{ dB} + (\text{Dialnorm}))$  [dB].

Dialnorm has no effect on the dynamics of the audio programme or the loudness ratios of dialogue, music, and effects. Only the overall level of the programme is controlled in relation to a reference value. The overall level of the programme is reduced if the Dialnorm value exceeds this reference value. The Dialnorm value is used by the decoder in the receiver to control the average overall volume in order to achieve a constant perceived loudness. This correction process operates slowly and smoothly and is not noticed by the listener.

## 1.7 Monitoring Controller Instruments

See Chapter 3.10 for operating instructions

### 1.7.1 The Monitoring Instrument

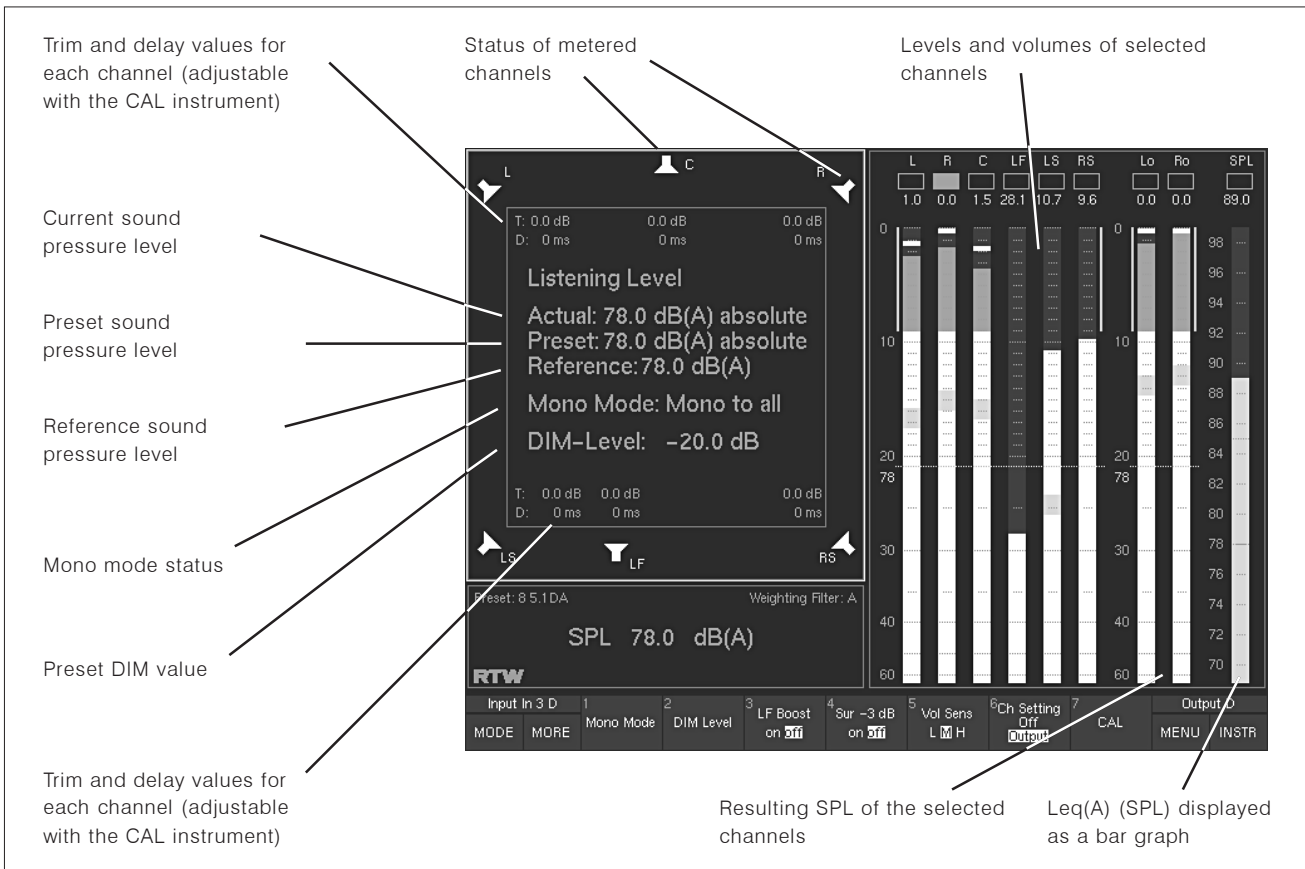

Fig. 1-18: The Monitoring instrument

This instrument is used to manage the functions configuration settings of the Monitoring Controller.

When the Monitoring instrument is activated a window is displayed showing symbols for the loudspeakers and the values of the level trim offset, the delay, the listening level setting, the reference level, the dimming level and the selected mode for generation of the mono signal.

See Chapter 3.11 for operating instructions



### The CAL Instrument (sub-function of the Monitoring instrument)

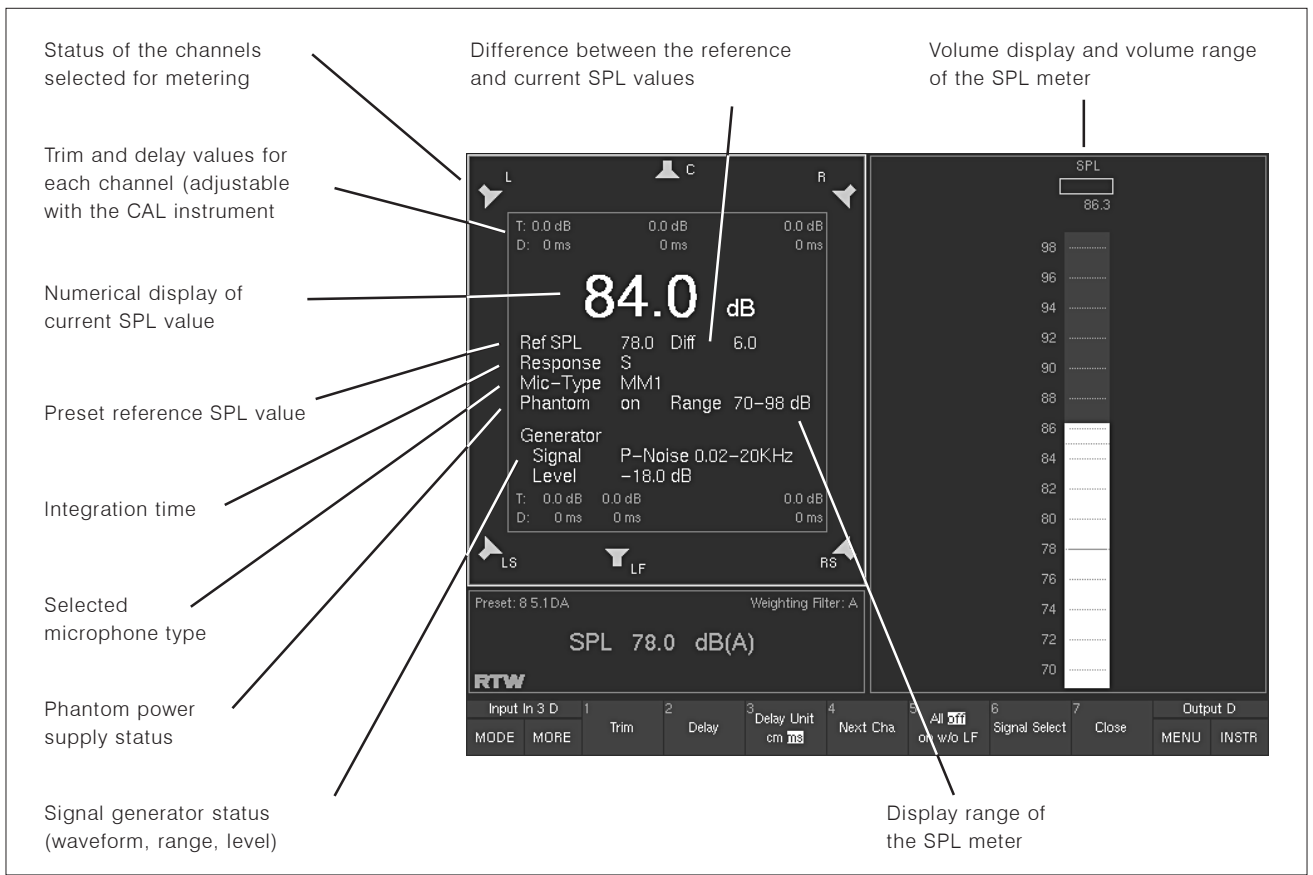

Fig. 1-19: The CAL (Calibration) instrument

This instrument provides an 8-channel test signal generator and an SPL meter for calibration of the monitoring system. The test signal generator can generate either sine wave signals or pink noise with a variety of bandwidths and levels. The values required for calibration to the various standards are preset, but you can also use variable values.

The SurroundControl 30900(-24)'s SPL meter enables you to perform the sound pressure level (SPL) measurements that are necessary to calibrate the sound monitoring system. The unit is also fitted with a calibration microphone preamplifier with settings for two different microphone types (i. e. beyerdynamic's MM-1 or Behringer's ECM 8000).



## 1.7.2 The Remote Control 30050

The Remote Control 30050 includes controls for all of the SurroundControl 30900(-24)'s monitoring functions and the metering functions. The metering functions can also be controlled with an optional computer mouse or with the function and control keys on the optional 8.4" Remote Display 30010 unit. One Remote Control 30050 is included in the standard SurroundControl 30900(-24) package but it is also available as an accessory because you can connect up to three Remote Control 30050 units simultaneously to the SurroundControl 30900(-24) (therefor see Chapter 3.16).

### Remote Control 30050 Key Functions:

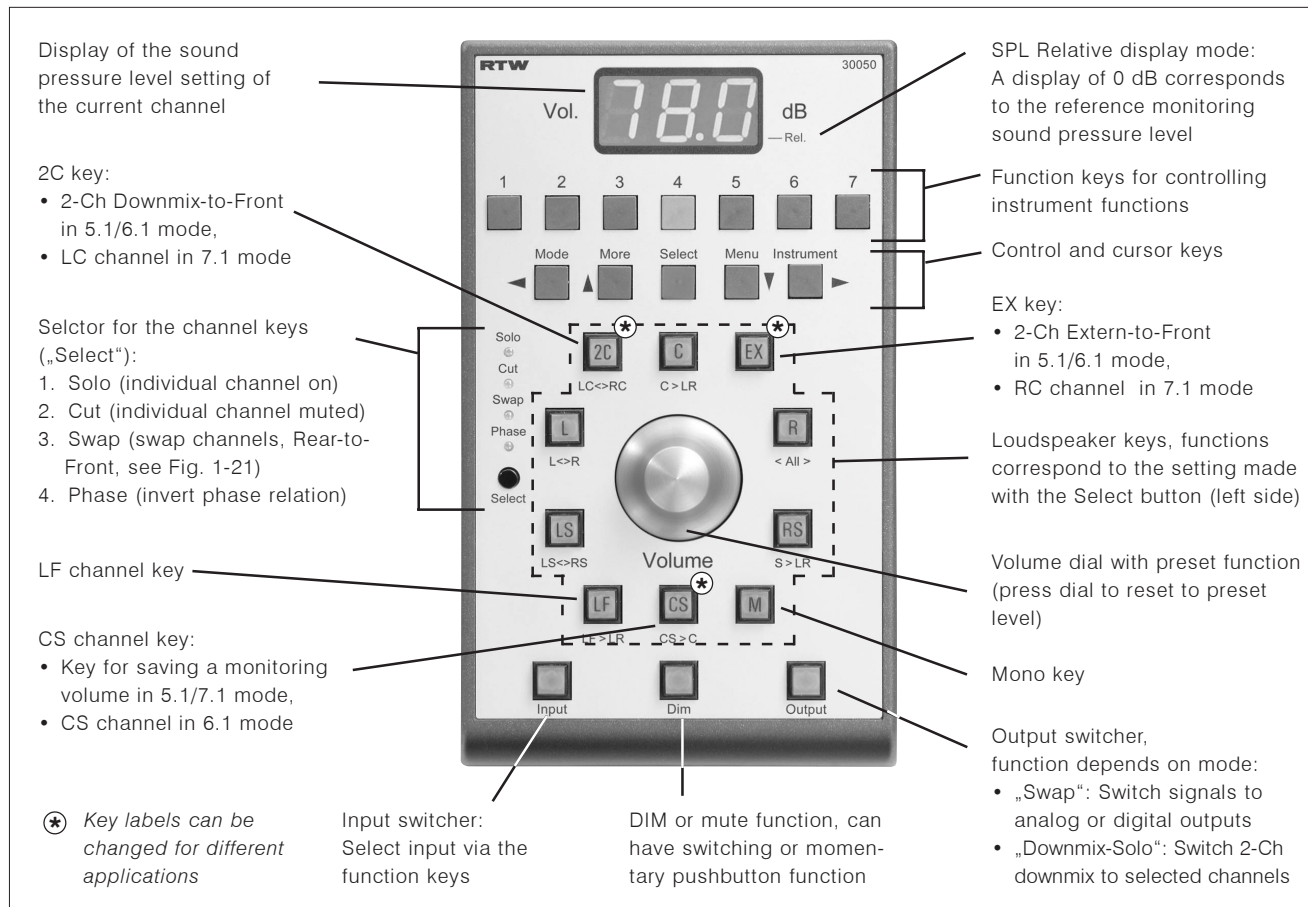

Fig. 1-20: Function keys of the Remote Control 30050

The Swap mode indicator LED on the left of the Remote Control 30050 unit has a blue label corresponding to the blue labels for the Channel Swap mode functions on the panel beneath the keys. When you activate Channel Swap mode with the Select button the Channel Swap functions shown by the blue labels on the panel are assigned to the channel keys. (See Fig. 1-21 on the next page for descriptions of these functions.)

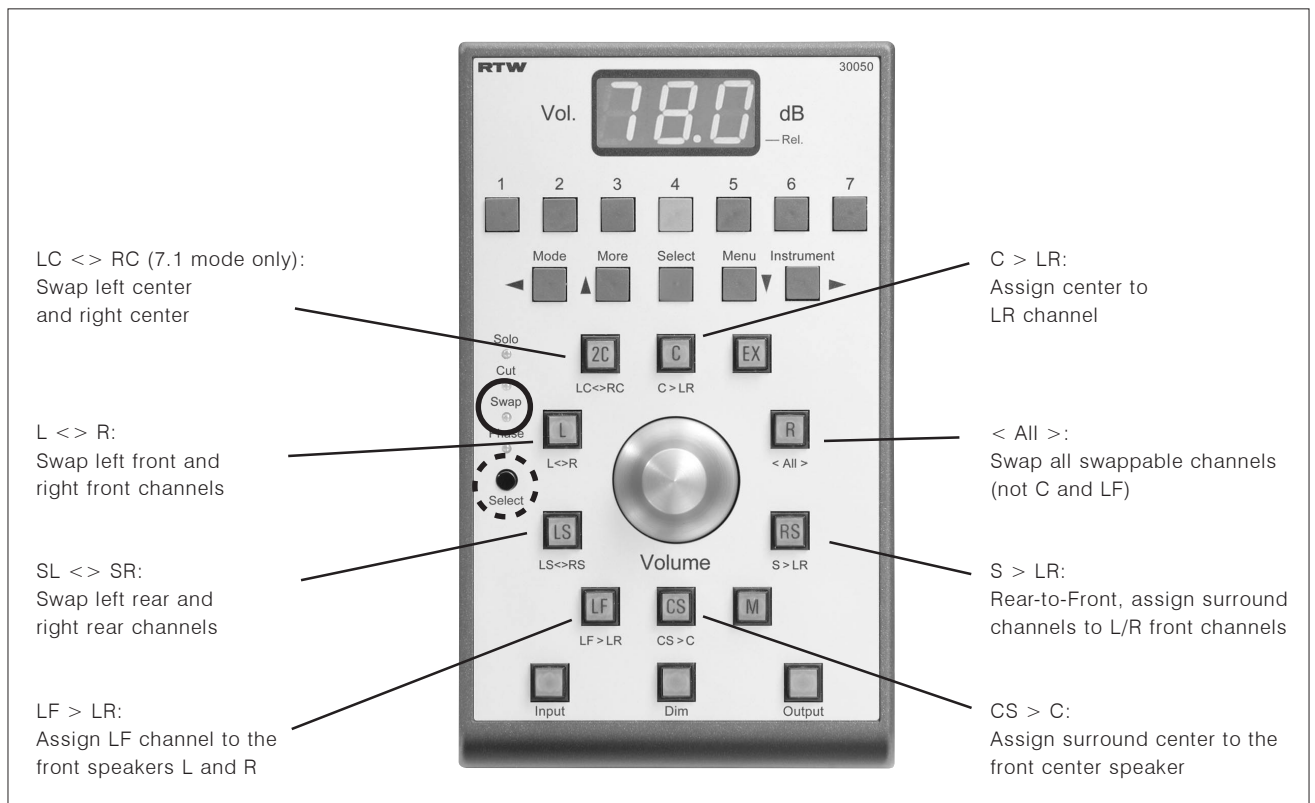

Fig. 1-21: Remote Control 30050 function keys assignments in Swap mode





# 2 Getting Started

## 2.1 Installation and Setup

The main SurroundControl 30900 or SurroundControl 30900(-24) unit is designed for installation in 19" rack systems. All necessary power supply voltages (including the power for the Remote Control 30050) are supplied by the integrated wide voltage power supply unit. The Remote Control 30050 is connected to the main unit with a cable fitted with a 9-pin Sub-D connector. The SurroundControl 30900(-24) can be operated either with the optional Remote Display 30010 from RTW or with a standard external VGA monitor. The Remote Display 30010 unit is powered by an external 24V DC power supply unit. A 5-meter VGA connection cable is included with the display unit.



If you need to purchase a replacement VGA connection cable for the Remote Display 30010 please make sure that **all** the pins of the connectors listed in Chapter 2.3.3 are wired as shown.

The other ports and interfaces are connected with the appropriate standard connection cables.

### Important information – please read before installing:

See chapters  
2.3.1. – 2.3.16.



- Before installing the unit please study the safety information in Chapter 2.2 and the information on connections in Chapters 2.3.1 to 2.3.16.
- Make sure that the power supply cord is **not** connected and the power switch on the front panel is in the OFF position.

See Fig. 2-2 and  
Chapter 2.3.3.



- Connect the Remote Control 30050 unit (included and required for operation of the SurroundControl) to the Remote connector on the rear panel of the main unit.

See Fig. 2-2 and  
Chapter 2.3.2.



- Connect the optional Remote Display 30010 unit to the VGA Out connector on the rear panel of the main unit using the VGA connection cable included with the display. Alternatively you can connect a standard VGA monitor to the same output, using a standard VGA connection cable.

See Fig. 2-2 and  
Chapter 2.3.4. – 2.3.16.



- Connect all your other components to the appropriate connectors on the SurroundControl 30900(-24), using the correct standard connection cables for the components.

See Chapter 2.3.1.



- Then connect the power with an earthed 3-wire power supply cord. **Never operate the unit without a properly earthed power supply cord!**
- Switch on the power. The SurroundControl 30900(-24) will then initiate its system startup sequence. This takes around 25 seconds, after which it is ready for use.

## 2.2 Safety Information

Before installing and configuring the unit please study the following safety information carefully and observe all the recommendations:



To prevent possible electrical shock, fire, injuries and malfunctions:

- Never open the housing.
- Never insert your fingers or any other objects into the housing.
- Never expose the unit to moisture and do not install it in a dusty environment.
- Never cover the unit or place any objects on it.
- Never operate the unit without adequate ventilation.
- Never place anything containing liquids on the unit.
- Turn off and disconnect the power supply immediately if the unit produces unusual smells, noises or smoke, or if foreign substances (e. g. liquids) or foreign objects enter the unit.



There are no user-serviceable parts in the SurroundControl 30900(-24). Please always have any necessary servicing performed by a properly qualified technician. Never remove any parts from the unit and do not make any modifications to the unit without the express written consent of RTW. Modifications can cause both safety hazards and affect the unit's EMI-CE conformity.



The SurroundControl 30900(-24) is designed for indoor use and may only be operated with a properly-earthed, 3-wire power supply cord.

## 2.3 Connections

All of the unit's audio inputs and audio outputs are electronically balanced.

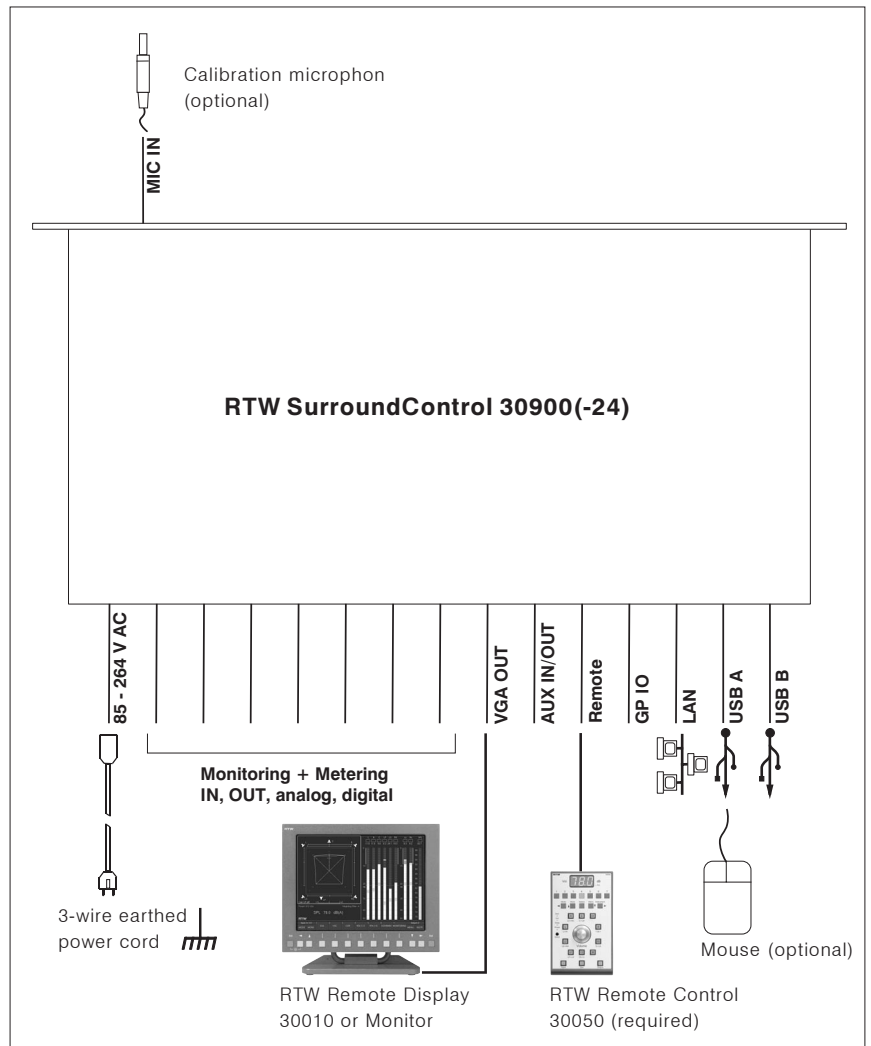

Fig. 2-1: Schematic representation of the unit's connections

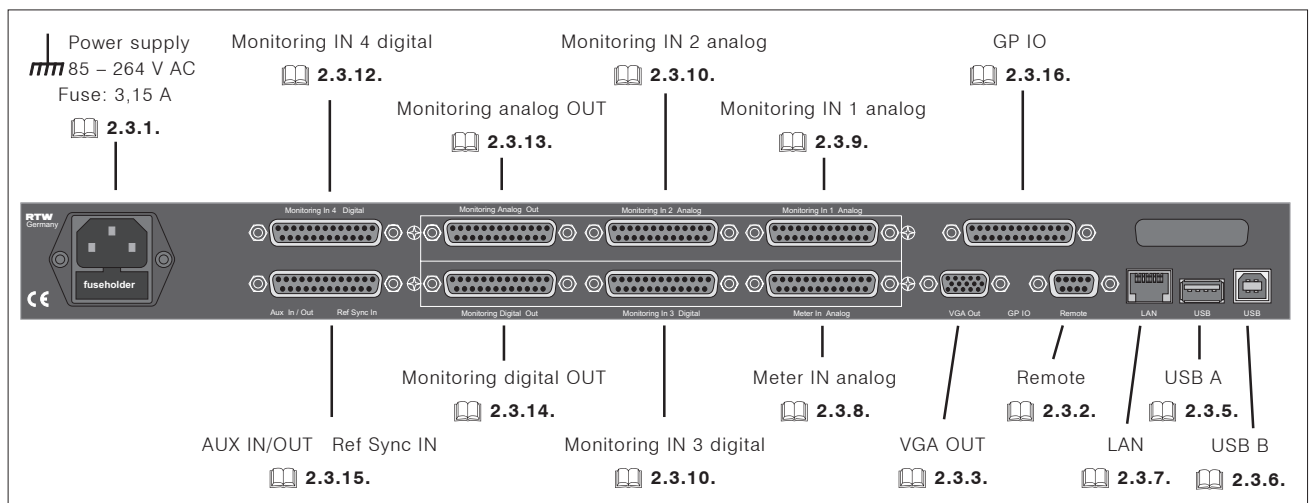

Fig. 2-2: Connectors on the rear panel of the SurroundControl 30900(-24)

### 2.3.1 Power Supply

The SurroundControl 30900(-24)'s integrated wide voltage power supply unit can be operated on mains voltages between 85 and 264 V AC. The power supply is fitted with a 3.15 A fuse, which is the same irrespective of the mains voltage. The unit must be connected with a properly-earthed 3-wire power cord.



### 2.3.2 Remote Connector

Remote is an RS-422 port and can only be used to connect the Remote Control 30050. You can connect up to three Remote Control 30050 units to this port simultaneously with external Y-adaptor cables.

The pins labelled “not used” in the table **must** remain unconnected!



9-pin Sub-D-F female connector

Pin:	Function:
1	Vcc +24 V DC
2	Not used
3	Tx +
4	Rx –
5	GND
6	GND
7	Tx –
8	Rx +
9	Not used

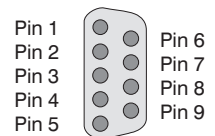

(External view of the connector)

The maximum total cable length for connection of 1 – 3 Remote Control 30050 units is 25 meters.

### 2.3.3 VGA-OUT Monitor Connector

15-pin female Sub-D-F connector

The pins labelled “not used” in the table **must** remain unconnected!



Pin:	Function:
1	R   Video signal
2	G
3	B
4	Not used
5	GND
6	GND
7	GND
8	GND
9	Not used
10	GND
11	Tx – Remote Display 30010
12	Rx – Remote Display 30010
13	H-sync
14	V-sync
15	Not used

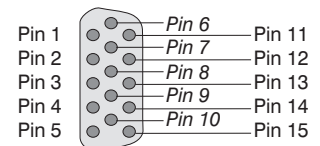

(External view of the connector)

Pins 11 and 12 are used for connection of the signals for the control keys on the optional Remote Display 30010.

### 2.3.4 LAN Connector

This is a standard network port with an RJ45 connector. It can be connected with a standard RJ45 network cable (not included).

### 2.3.5 USB A Connector

This is a standard USB 1.1 port for connection of an optional computer mouse (not included).

### 2.3.6 USB B Connector

This connector is currently not used.

### 2.3.7 XLR Connector

This connector is located on the front panel of the 19"/1U SurroundControl 30900(-24) main unit. It is used for connection of a calibration microphone.

3-pin XLR-F connector

Pin:	Function:
1	Shield/Chassis
2	+, hot
3	-, cold

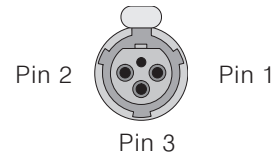

(External view of the connector)

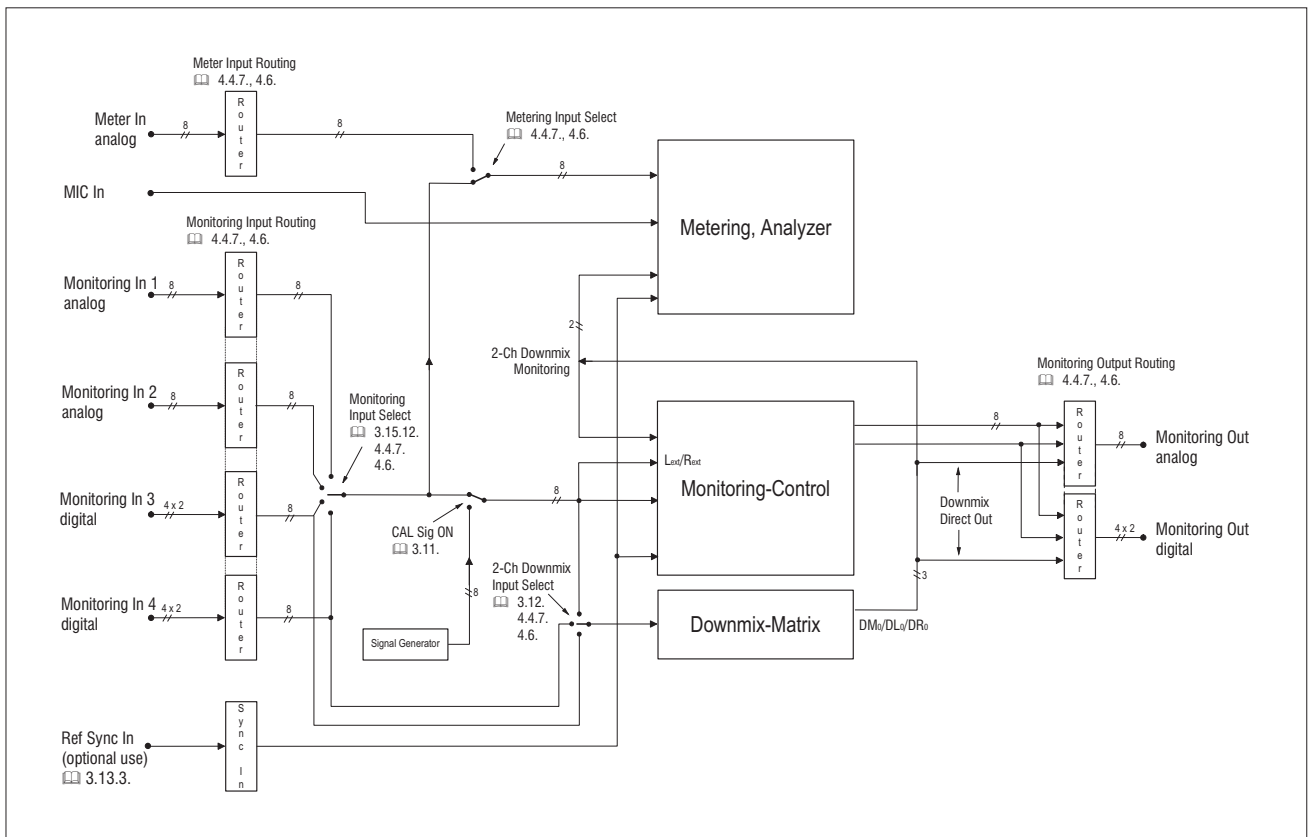

Fig. 2-3: Information flowchart SurroundControl 30900(-24)

## 2.3.8 Meter IN Analog Connector

This is an 8-channel analog input for the metering functions.

25-pin female Sub-D-F connector

Pin:	Function:
1	Analog audio input 8 (+, hot)
14	Analog audio input 8 (-, cold)
2	Shield/chassis
15	Analog audio input 7 (+, hot)
3	Analog audio input 7 (-, cold)
16	Shield/chassis
4	Analog audio input 6 (+, hot)
17	Analog audio input 6 (-, cold)
5	Shield/chassis
18	Analog audio input 5 (+, hot)
6	Analog audio input 5 (-, cold)
19	Shield/chassis
7	Analog audio input 4 (+, hot)
20	Analog audio input 4 (-, cold)
8	Shield/chassis
21	Analog audio input 3 (+, hot)
9	Analog audio input 3 (-, cold)
22	Shield/chassis
10	Analog audio input 2 (+, hot)
23	Analog audio input 2 (-, cold)
11	Shield/chassis
24	Analog audio input 1 (+, hot)
12	Analog audio input 1 (-, cold)
25	Shield/chassis

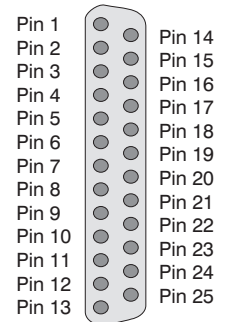

*(External view of the connector)*

### 2.3.9 Monitoring IN 1 Analog Connector

This is an 8-channel analog input for the monitoring functions.

25-pin female Sub-D-F connector

Pin:	Function:
1	Analog audio input 8 (+, hot)
14	Analog audio input 8 (-, cold)
2	Shield/chassis
15	Analog audio input 7 (+, hot)
3	Analog audio input 7 (-, cold)
16	Shield/chassis
4	Analog audio input 6 (+, hot)
17	Analog audio input 6 (-, cold)
5	Shield/chassis
18	Analog audio input 5 (+, hot)
6	Analog audio input 5 (-, cold)
19	Shield/chassis
7	Analog audio input 4 (+, hot)
20	Analog audio input 4 (-, cold)
8	Shield/chassis
21	Analog audio input 3 (+, hot)
9	Analog audio input 3 (-, cold)
22	Shield/chassis
10	Analog audio input 2 (+, hot)
23	Analog audio input 2 (-, cold)
11	Shield/chassis
24	Analog audio input 1 (+, hot)
12	Analog audio input 1 (-, cold)
25	Shield/chassis

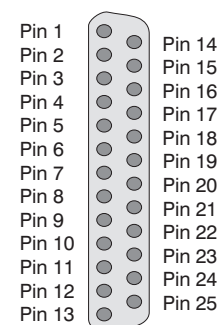

*(External view of the connector)*

### 2.3.10 Monitoring IN 2 Analog Connector

This is an 8-channel analog input for the monitoring functions.

25-pin female Sub-D-F connector

Pin:	Function:
1	Analog audio input 8 (+, hot)
14	Analog audio input 8 (-, cold)
2	Shield/chassis
15	Analog audio input 7 (+, hot)
3	Analog audio input 7 (-, cold)
16	Shield/chassis
4	Analog audio input 6 (+, hot)
17	Analog audio input 6 (-, cold)
5	Shield/chassis
18	Analog audio input 5 (+, hot)
6	Analog audio input 5 (-, cold)
19	Shield/chassis
7	Analog audio input 4 (+, hot)
20	Analog audio input 4 (-, cold)
8	Shield/chassis
21	Analog audio input 3 (+, hot)
9	Analog audio input 3 (-, cold)
22	Shield/chassis
10	Analog audio input 2 (+, hot)
23	Analog audio input 2 (-, cold)
11	Shield/chassis
24	Analog audio input 1 (+, hot)
12	Analog audio input 1 (-, cold)
25	Shield/chassis

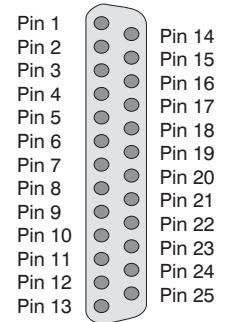

*(External view of the connector)*



### 2.3.11 Monitoring IN 3 Digital Connector

This is a 4-fold AES/EBU interface for metering and monitoring.

25-pin female Sub-D-F connector:

Pin:	Function:
1	Not used
14	Not used
2	Not used
15	Not used
3	Not used
16	Not used
4	Not used
17	Not used
5	Not used
18	Not used
6	Not used
19	Not used
7	Digital audio input 4 (+, hot)
20	Digital audio input 4 (-, cold)
8	Shield/chassis
21	Digital audio input 3 (+, hot)
9	Digital audio input 3 (-, cold)
22	Shield/chassis
10	Digital audio input 2 (+, hot)
23	Digital audio input 2 (-, cold)
11	Shield/chassis
24	Digital audio input 1 (+, hot)
12	Digital audio input 1 (-, cold)
25	Shield/chassis

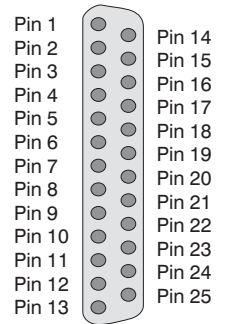

*(External view of the connector)*

The AES/EBU inputs are permanently terminated with 110  $\Omega$ .

### 2.3.12 Monitoring IN 4 Digital Connector

This is a 4-fold AES/EBU interface for metering and monitoring.

25-pin female Sub-D-F connector:

Pin:	Function:
1	Not used
14	Not used
2	Not used
15	Not used
3	Not used
16	Not used
4	Not used
17	Not used
5	Not used
18	Not used
6	Not used
19	Not used
7	Digital audio input 4 (+, hot)
20	Digital audio input 4 (-, cold)
8	Shield/chassis
21	Digital audio input 3 (+, hot)
9	Digital audio input 3 (-, cold)
22	Shield/chassis
10	Digital audio input 2 (+, hot)
23	Digital audio input 2 (-, cold)
11	Shield/chassis
24	Digital audio input 1 (+, hot)
12	Digital audio input 1 (-, cold)
25	Shield/chassis

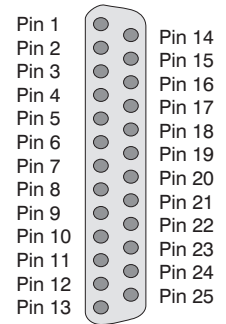

*(External view of the connector)*

The AES/EBU inputs are permanently terminated with 110  $\Omega$ .

### 2.3.13 Monitoring Analog OUT Connector

This 8-channel analog output is for the monitoring functions and is used to connect the analog monitoring loudspeakers.

25-pin female Sub-D-F connector:

Pin:	Function:
1	Analog audio output 8 (+, hot)
14	Analog audio output 8 (-, cold)
2	Shield/chassis
15	Analog audio output 7 (+, hot)
3	Analog audio output 7 (-, cold)
16	Shield/chassis
4	Analog audio output 6 (+, hot)
17	Analog audio output 6 (-, cold)
5	Shield/chassis
18	Analog audio output 5 (+, hot)
6	Analog audio output 5 (-, cold)
19	Shield/chassis
7	Analog audio output 4 (+, hot)
20	Analog audio output 4 (-, cold)
8	Shield/chassis
21	Analog audio output 3 (+, hot)
9	Analog audio output 3 (-, cold)
22	Shield/chassis
10	Analog audio output 2 (+, hot)
23	Analog audio output 2 (-, cold)
11	Shield/chassis
24	Analog audio output 1 (+, hot)
12	Analog audio output 1 (-, cold)
25	Shield/chassis

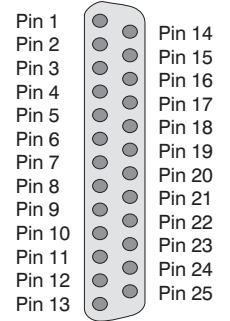

*(External view of the connector)*

### 2.3.14 Monitoring Digital OUT Connector

This 4-fold digital output is for the monitoring functions and is used to connect the digital monitoring loudspeakers.

25-pin female Sub-D-F connector:

Pin:	Function:
1	Not used
14	Not used
2	Not used
15	Not used
3	Not used
16	Not used
4	Not used
17	Not used
5	Not used
18	Not used
6	Not used
19	Not used
7	Digital audio output 4 (+, hot)
20	Digital audio output 4 (-, cold)
8	Shield/chassis
21	Digital audio output 3 (+, hot)
9	Digital audio output 3 (-, cold)
22	Shield/chassis
10	Digital audio output 2 (+, hot)
23	Digital audio output 2 (-, cold)
11	Shield/chassis
24	Digital audio output 1 (+, hot)
12	Digital audio output 1 (-, cold)
25	Shield/chassis

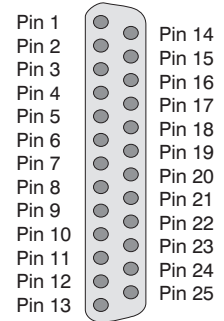

*(External view of the connector)*

### 2.3.15 Aux IN/OUT Ref Sync IN Connector

This is an 8-channel connection to which the AUX input and output signals and/or external sync signals can be connected.

25-pin female Sub-D-F connector:

The pins labelled "not used" in the table **must** remain unconnected!



Pin:	Function:
1	not used
14	not used
2	Shield/chassis
15	not used
3	not used
16	Shield/chassis
4	Preamp OUT (+, heiß)
17	Preamp OUT (-, kalt)
5	Shield/chassis
18	not used
6	not used
19	Schirm/Gehäuse
7	not used
20	not used
8	Shield/chassis
21	not used
9	not used
22	Shield/chassis
10	not used
23	not used
11	Shield/chassis
24	AES/EBU-sync in (+, heiß)
12	AES/EBU-sync in (-, kalt)
25	Shield/chassis

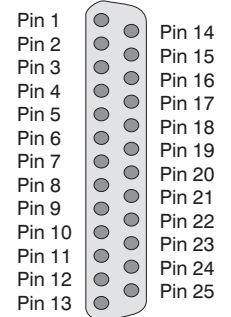

(External view of the connector)

Permanently terminated with 110 Ω

The AES/EBU-sync input is permanently terminated with 110 Ω.

## 2.3.16 GP IO Connector (General-purpose Input/Output)

This interface can be used for the input and the output of control signals.

25-pin female Sub-D-F connector:

See Chapter 4.12 and Figs. 3-29, 4-30 and 4-31

See Chapter 4.12.4 and Figs. 3-29 and 4-30

See Chapter 4.12.4

See Chapter 4.11.4 and Fig. 4-29

Pin:	Function:
1	GP IO IN Function key 1
2	GP IO IN Function key 2
3	GP IO IN Function key 3
4	GP IO IN Function key 4
5	GP IO IN Function key 5
6	GP IO IN Function key 6
7	GP IO IN Function key 7
8	GP IO IN Control key MODE
9	GP IO IN Control key MENU
10	GP IO IN Control key MOrE
11	GP IO IN Control key INSTR(UMENT)
12	GP IO IN Select key SEL(ECT)
13	GP IO IN Key Input (parallel to key on Remote Control 30050)
14	GP IO IN Key DIM (parallel to key on Remote Control 30050)
15	GP IO IN Key Output (parallel to key on Remote Control 30050)
16	GP IO IN Mute on/off key ( <b>NOT</b> on Remote Control 30050)
17	GP IO OUT Output 1
18	GP IO OUT Output 2
19	GP IO OUT Output 3
20	GP IO OUT Output 4
21	GP IO OUT Output 5
22	GP IO OUT Output 6
23	GP IO OUT Output 7
24	GP IO OUT Output 8
25	Common potential and shield/chassis

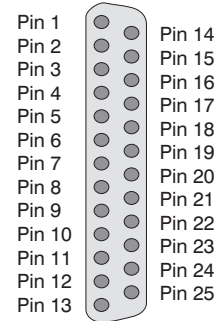

(External view of the connector)



### Please note:

- All GP IO inputs are active low. The pins each have to be connected with Pin 25 for switching the corresponding function.
- The logic state of the GP IO outputs is selectable via Alarm Configuration menu (see Chapter 4.11). The pins each have to be connected with Pin 25 for switching the corresponding function.
- The described assignments are factory-made standard settings.
  - Using the Key Setting menu (see Chapter 4.12) keys, groups of keys or control inputs (see above) can be locked or can have other functions (i. e. preset call).
  - Using the Alarm Configuration menu (see Chapter 4.11) different alarm events can be selected to put out via the several control outputs (see above).

## 2.4 Presets

The SurroundControl 30900(-24) features 7 Factory- (F 15 to F 21) and 14 User- (U 1 to U 14) Presets. When delivered from the factory the factory programmed presets are copied into the User-Presets U 1 to U 7 and again into the User-Presets U 8 to U 14. The User-Presets provide a basis for own settings.



Please note, that all **Factory-Presets** are set to **Use Local Routing Settings** (see Chapter 4.4.1) and that thus uses the **local** routing settings (see Chapter 4.4.7)!

→ MODE → MORE → MORE  
→ MORE → MORE  
→ Button/key 1

See Chapters 4.1 and 4.4



### 2.4.1 Preset F 15: 5.1 DA

(copied to: U 1 and U 8)

Definition:	<ul style="list-style-type: none"><li>• 5.1 format</li><li>• Digital input</li><li>• Analog output</li></ul>
Input:	Monitoring In 3 digital (📖 2.3.11)
Output:	Monitoring analog Out: (📖 2.3.13.)
Output mode:	Downmix Solo (📖 4.4.7, 4.6)
Scale PPM:	60 dB FS (📖 4.13)
Select default instrument:	Surround Sound Analyzer (📖 4.4.1)
Downmix Input Source:	Monitor Input (📖 4.4.7, 4.6)
DL <sub>0</sub> /DR <sub>0</sub> Out:	-- (📖 2.3.9)
Routing Input(s):	Standard configuration (📖 2.4.8)
Routing Output(s):	Standard configuration (📖 2.4.8)
Use Local Routing Settings:	Activated (📖 4.4.1)

→ MODE → MORE → MORE  
→ MORE → MORE  
→ Button/key 2

See Chapters 4.1 and 4.4



### 2.4.2 Preset F 16: 5.1 DD

(copied to: U 2 and U 9)

Definition:	<ul style="list-style-type: none"><li>• 5.1 format</li><li>• Digital input</li><li>• Digital output</li></ul>
Input:	Monitoring In 3 digital (📖 2.3.11)
Output:	Monitoring digital Out: (📖 2.3.14)
Output mode:	Downmix Solo (📖 4.4.7, 4.6)
Scale PPM:	60 dB FS (📖 4.13)
Select default instrument:	Surround Sound Analyzer (📖 4.4.1)
Downmix Input Source:	Monitor Input (📖 4.4.7, 4.6)
DL <sub>0</sub> /DR <sub>0</sub> Out:	-- (📖 2.3.4)
Routing Input(s):	Standard configuration (📖 2.4.8)
Routing Output(s):	Standard configuration (📖 2.4.8)
Use Local Routing Settings:	Activated (📖 4.4.1)

→ MODE → MORE → MORE  
 → MORE → MORE  
 → Button/key 3

See Chapters 4.1 and 4.4



### 2.4.3 Preset F 17: 5.1 AA

(copied to: U 3 and U 10)

Definition:	<ul style="list-style-type: none"> <li>• 5.1 format</li> <li>• Analog input</li> <li>• Analog output</li> </ul>
Input:	Monitoring In 1 analog (📖 2.3.4)
Output:	Monitoring analog Out: (📖 2.3.13)
Output mode:	Downmix Solo (📖 4.4.7, 4.6)
Scale PPM:	DIN (📖 4.13)
Select default instrument:	Surround Sound Analyzer (📖 4.4.1)
Downmix Input Source:	Monitor Input (📖 4.4.7, 4.6)
DL <sub>0</sub> /DR <sub>0</sub> Out:	– – (📖 2.3.9)
Routing Input(s):	Standard configuration (📖 2.4.8)
Routing Output(s):	Standard configuration (📖 2.4.8)
Use Local Routing Settings:	Activated (📖 4.4.1)

→ MODE → MORE → MORE  
 → MORE → MORE  
 → Button/key 4

See Chapters 4.1 and 4.4



### 2.4.4 Preset F 18: 5.1 AD

(copied to: U 4 and U 11)

Definition:	<ul style="list-style-type: none"> <li>• 5.1 format</li> <li>• Analog input</li> <li>• Digital output</li> </ul>
Input:	Monitoring In 1 analog (📖 2.3.9)
Output:	Monitoring digital Out: (📖 2.3.14)
Output mode:	Downmix Solo (📖 4.4.7, 4.6)
Scale PPM:	DIN (📖 4.13)
Select default instrument:	Surround Sound Analyzer (📖 4.4.1)
Downmix Input Source:	Monitor Input (📖 4.4.7, 4.6)
DL <sub>0</sub> /DR <sub>0</sub> Out:	– – (📖 2.3.9)
Routing Input(s):	Standard configuration (📖 2.4.8)
Routing Output(s):	Standard configuration (📖 2.4.8)
Use Local Routing Settings:	Activated (📖 4.4.1)

→ MODE → MORE → MORE  
 → MORE → MORE  
 → Button/key 5

See Chapters 4.1 and 4.4



### 2.4.5 Preset F 19: 5.1 DA2

(copied to: U 5 and U 12)

Definition:	<ul style="list-style-type: none"> <li>• 5.1 format</li> <li>• Digital input</li> <li>• Analog output</li> <li>• Direct Downmix out digital</li> </ul>
Input:	Monitoring In 3 digital (📖 2.3.11)
Output:	Monitoring analog Out: (📖 2.3.13)
Output mode:	Downmix Solo (📖 4.4.7, 4.6)
Scale PPM:	60 dB FS (📖 4.13)
Select default instrument:	Surround Sound Analyzer (📖 4.4.1)
Downmix Input Source:	Monitoring In 3 digital (📖 4.4.7, 4.6)
DL <sub>0</sub> /DR <sub>0</sub> Out:	Monitoring digital out (4) (📖 4.4.7, 4.6)
L <sub>ext</sub> /R <sub>ext</sub> Out:	Monitoring digital out (3) (📖 4.4.7, 4.6)
Routing Input(s):	Standard configuration (📖 2.4.8)
Routing Output(s):	Standard configuration (📖 2.4.8)
Use Local Routing Settings:	Activated (📖 4.4.1)



→ MODE → MORE → MORE  
 → MORE → MORE  
 → Button/key 6

See Chapters 4.1 and 4.4



## 2.4.6 Preset F 20: 5.1 DD2

(copied to: U 6 and U 13)

Definition:

- 5.1 format
- Digital input
- Digital output
- Direct Downmix out digital

Input:	Monitoring In 3 digital	( 2.3.11)
Output:	Monitoring digital Out:	( 2.3.14)
Output mode:	Swap Analog Digital	( 4.4.7, 4.6)
Scale PPM:	60 dB FS	( 4.13)
Select default instrument:	Surround Sound Analyzer	( 4.4.1)
Downmix Input Source:	Monitoring In 3 digital	( 4.4.7, 4.6)
DL <sub>0</sub> /DR <sub>0</sub> Out:	Monitoring digital out (4)	( 4.4.7, 4.6)
L <sub>ext</sub> /R <sub>ext</sub> Out:	Monitoring analog out (5-6)	( 4.4.7, 4.6)
VL <sub>0</sub> /VR <sub>0</sub> Out:	Monitoring analog out (7-8)	( 4.4.7, 4.6)
Routing Input(s):	Standard configuration	( 2.4.8)
Routing Output(s):	Standard configuration	( 2.4.8)
Use Local Routing Settings:	Activated	( 4.4.1)

→ MODE → MORE → MORE  
 → MORE → MORE  
 → Button/key 7

See Chapters 4.1 and 4.4



## 2.4.7 Preset F 21: 7.1 DA







(copied to: U 7 and U 14)

Definition:

- 7.1 format
- Digital input
- Digital output
- Downmix Monitoring  
(digital input, analog output)
- Direct Downmix out digital

Input:	Monitoring In 3 digital	( 2.3.11)
Output:	Monitoring analog Out:	( 2.3.13)
Output mode:	Swap Analog Digital	( 4.4.7, 4.6)
Scale PPM:	60 dB FS	( 4.13)
Select default instrument:	Surround Sound Analyzer	( 4.4.1)
Downmix Input Source:	Monitor input	( 4.4.7, 4.6)
DL <sub>0</sub> /DR <sub>0</sub> Out:	Monitoring digital out (3)	( 4.4.7, 4.6)
VL <sub>0</sub> /VR <sub>0</sub> Out:	Monitoring digital out (4)	( 4.4.7, 4.6)
Routing Input(s):	Standard configuration	( 2.4.8)
Routing Output(s):	Standard configuration	( 2.4.8)
Use Local Routing Settings:	Activated	( 4.4.1)

## 2.4.8 Note for Audio Signal Wiring

Standard Channel Configuration				
In/Out analog 25-pin Sub-D-F	XLR connector (RTW 1186)	In/Out digital 25-pin Sub-D-F	XLR connector (RTW 1186)	Internal channels (Surround)
1	1	1A	1	L
2	2	1B	1	R
3	3	2A	2	C
4	4	2B	2	LF
5	5	3A	3	LS
6	6	3B	3	RS
7	7	4A	4	L <sub>ext</sub> (inputs only)
8	8	4B	4	R <sub>ext</sub> (inputs only)
 <b>2.3.8</b>  <b>2.3.9</b>  <b>2.3.10</b>  <b>2.3.13</b>		 <b>2.3.11</b>  <b>2.3.12</b>  <b>2.3.14</b>		
RTW 1186: 8-pair snake cable 25-pin Sub-D-M to 8 XLR-F				

# 3 Operation

## 3.1 Operating Options

The SurroundControl 30900(-24) can be operated in three different ways: With the Remote Control 30050 unit, with an optional computer mouse using the controls displayed in the Toolbar on the screen (Window 1), or with the control keys on the optional Remote Display 30010 unit.

All the system's functions and setup menus except the monitoring functions can be accessed with the optional mouse and the control keys on the Remote Display 30010. The Remote Control 30050 has all the same keys available on the Remote Display 30010 unit, plus a numerical display and keys and controls for operation of the monitoring functions.

Fig. 3-1 shows the key layouts of the Remote Display 30010 and the Remote Control 30050 units and an example of a Toolbar as displayed on the screen.

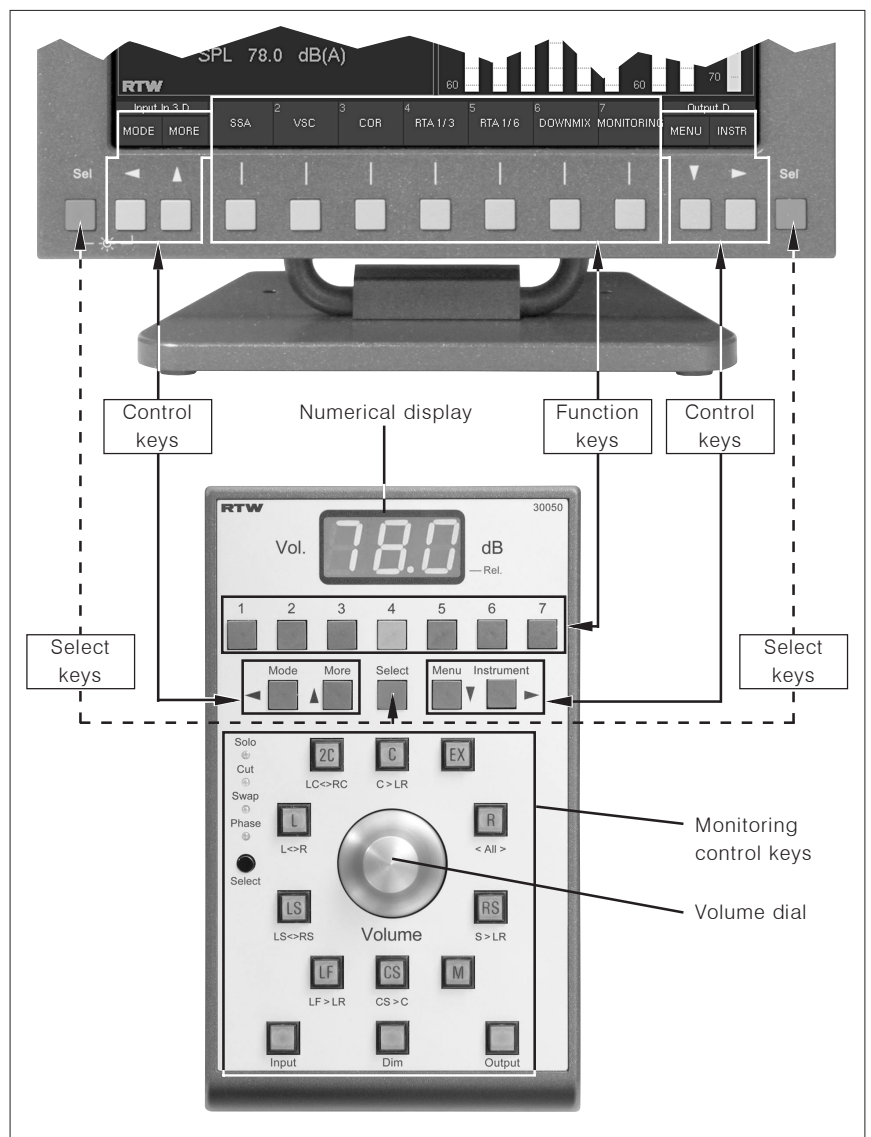

Fig. 3-1: The SurroundControl 30900(-24) controls

## 3.2 The Control Keys and the Toolbar

The Remote Control 30050 and Remote Display 30010 have a total of 11 keys for operating the SurroundControl 30900(-24) system. On-screen buttons providing the same control functions for access with an optional mouse are displayed in the Toolbar in Window 1 of the display.

Function keys see Fig. 3-1



The functions assigned to function keys 1 – 7 change depending on the current system mode. The functions that are currently active are displayed in the Toolbar. These keys can function as either pushbuttons or switches, and they can also be used to adjust settings with up to three options for some instruments. The current option is highlighted (see illustration on the left) and you can switch between the available options by pressing the key or clicking the corresponding button repeatedly.

Control keys see Fig. 3-1

→ MODE

→ MORE

→ „MENU“

→ „INSTRUMENT“



Two pairs of control keys are located to the left and right of the function keys on the Remote Display 30010 and below the function keys on the Remote Control 30050:

- **MODE:** Switches between Function Select and Instrument Select modes.
- **MORE:** Moves down to the next Toolbar level. When you are on the last available level selecting MORE returns you to the first level. The text in the Toolbar buttons also changes to grey when no more levels are available.
- **MENU:** Opens the configuration menu pages in which you can view and adjust settings.
- **INSTR:** Stands for “Instrument” and switches the focus between Window 2 and Window 3.

In the configuration menus these four keys function as cursor keys.

Select keys see Fig. 3-1

→ „SEL(ECT)“



The Remote Control 30050 has one Select key and the Remote Display 30010 has two Select keys. These keys are used to confirm selections in the menus. When you are using the optional mouse the left mouse key is used to confirm selections.

The buttons displayed in the Toolbar are numbered. These numbers correspond to the numbers above the function keys on the Remote Control 30050 unit (see Fig. 3-1).

In addition to pushbutton and switch function buttons the Toolbar also includes displays for the current input and output status (see Fig. 3-2) of the SurroundControl 30900(-24). You can change the current selections by pressing the Input and Output keys on the Remote Control 30050 (see Fig. 3-1) or by clicking the Toolbar buttons with the optional mouse.

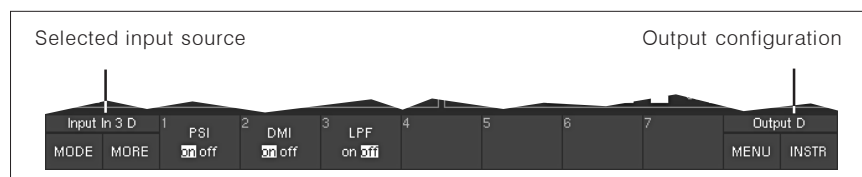

Fig. 3-2: The Toolbar buttons for selecting the input source and the output configuration

### 3.3 Toolbar Modes: Function Select and Instrument Select

→ MODE

See Chapter 3.3.1  
See Chapter 3.3.2



The Toolbar has two different modes which can be selected with the MODE key:

- **Function Select:** Mode for operating the instruments
- **Instrument Select:** Mode for selecting an instrument or a preset

The default mode is Function Select.

#### 3.3.1 Function Select

→ INSTR

When Function Select mode is active you can operate the active instrument, which is identified by a highlighted frame around the instrument window. You can switch the focus between Window 2 and Window 3 by pressing the INSTR key or clicking in the window with the left mouse key. Window 1 (Toolbar) and Window 4 (Status Box) can never be given the focus (made active) because this mode is not relevant for them.

→ (Button/key 1 – 7)

The available functions for the active instrument are shown as buttons in the Toolbar. If more than 7 functions are available the additional functions can be displayed by selecting MORE.

→ MORE → (other functions)

#### 3.3.2 Instrument Select

→ MODE → (Instruments)

In this mode there are two Toolbar levels for selecting the available instruments and three additional levels with 7 factory presets and 14 user presets. To display an instrument in Window 3 and activate it just press the corresponding function key or optional click on its Toolbar button with the mouse. When you select a new instrument the current settings of the instrument you were using are stored automatically and restored when you return to the instrument again later.

→ MODE → MORE

→ (other instruments)

**Example:**

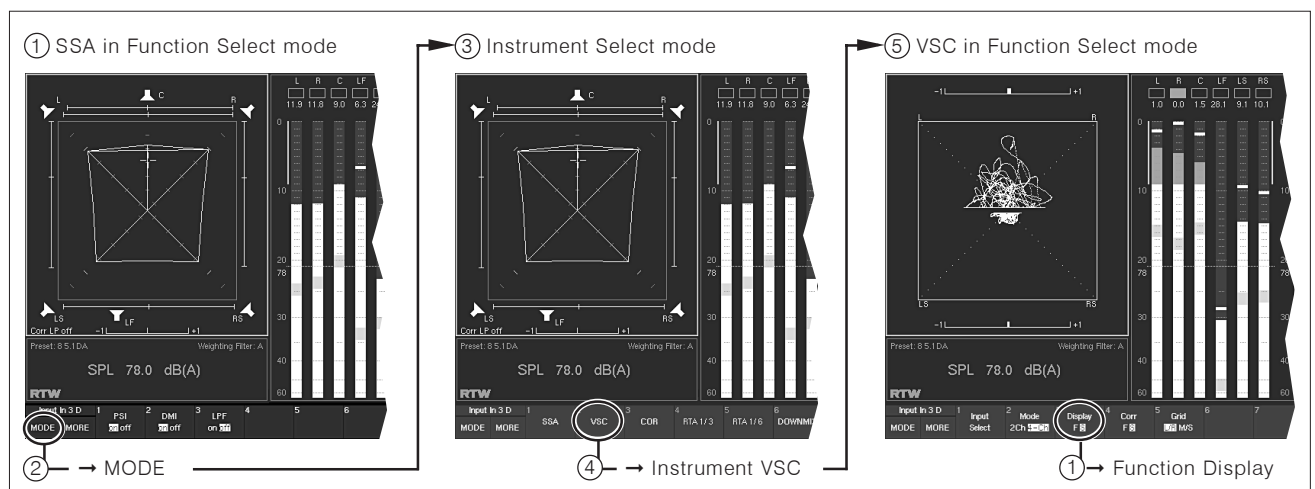

Fig. 3-3: Changing between Function Select and Instrument Select mode when selecting another instrument. Example with the instruments SSA and VSC

Function Select  
 (see Chapter 3.3.1):  
 → INSTR



## 3.4 Functions of the PPM Instrument

Brief description in  
 Chapter 1.6.1



Focus on Window 2  
 (highlighted frame)

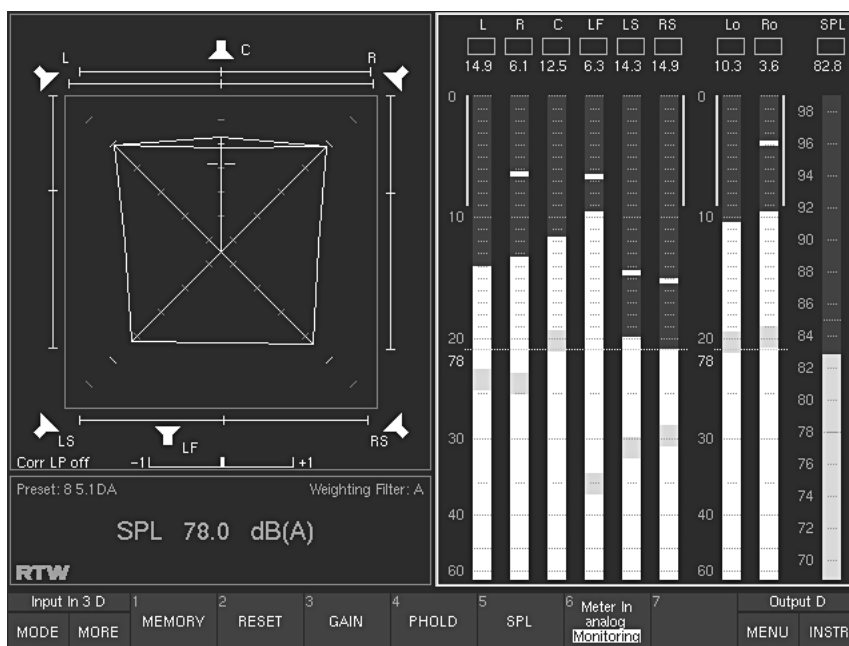

Fig. 3-4: Screen display with PPM instrument selected

The PPM instrument is always displayed in Window 2. To select it assign the focus to it (indicated by a highlighted frame around the window) by pressing the INSTR key. When the focus is on this window the Peak Program Meter functions are displayed in the Toolbar. (The PPM functions are available simultaneously with all other instruments except the RTA 1/6 instrument, which covers Window 2 and thus hides the peakmeter.) Pressing the INSTR key again returns the focus to Window 3 and displays the functions of the instrument displayed there in the Toolbar (Window 1).

Functions of the PPM instrument:

### 3.4.1 Memory

(Button/Key 1, see Fig. 3-4)

Depending on the preset this function activates the numerical display of the long-term memory for maximum level, volume level, most negative correlation or digital errors.

### 3.4.2 Reset

(Button/key 2, see Fig. 3-4)

This function deletes the long-term memory, the peak hold memory and the stored digital errors.

### 3.4.3 Gain

(Button/key 3, see Fig. 3-4)

This function activates the measurement range expansion and simultaneously switches the peak meter scale. The following gain increases are applied in accordance with the scale standards:

Mode/Standard	Gain
Digital scales	40 dB
DIN	20 dB
Nordic	40 dB
British IIa + IIb	40 dB
VU	20 dB
Zoom20	20 dB
+24 dBu	20 dB
+20 dBr	20 dB

For digital input signals the reference point on scales DIN+5, DIN+10, Nordic, British IIa, British IIb, Zoom20 and Zoom2 corresponds to the set headroom value. Factory default: -9 dB FS.

### 3.4.4 PHold

(Button/key 4, see Fig. 3-4)

This function activates or deactivates the PPM's peak hold display. The function has no effect on the numerical display.

### 3.4.5 SPL

(Button/key 5, see Fig. 3-4)

This function activates or deactivates the volume level displays of the individual channels.

### 3.4.6 Meter In

(Button/key 6, see Fig. 3-4)

This function switches between the analog signal source of the Meter In analog connector described in Chapter 2.3.8 (Meter In analog) or the signal being used for monitoring (Meter In Monitoring) to be shown on the peak meter displays.

See Chapter 2.3.8



Instrument Select  
(see Chapter 3.3.2):  
→ MODE → SSA



## 3.5 Functions of the SSA Instrument

Brief description in  
Chapter 1.6.2



Focus on Window 3  
(highlighted frame)



The SSA instrument is **only**  
available in Surround mode!

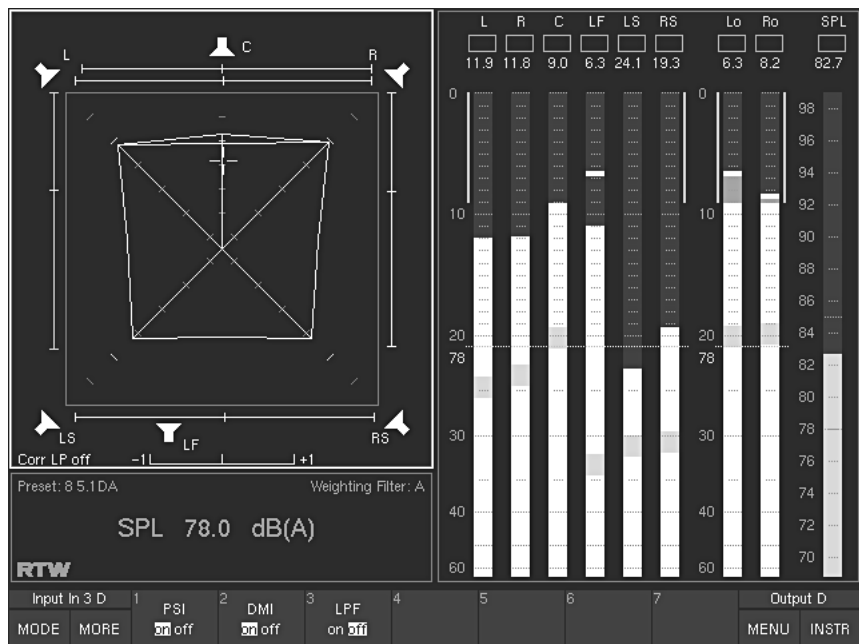

Fig. 3-5: Screen display with SSA instrument selected

### 3.5.1 PSI

(Button/key 1, see Fig. 3-5)

The PSI function (Phantom Source Indicator) activates or deactivates the indicators for phantom sound sources.

### 3.5.2 DMI

(Button/key 2, see Fig. 3-5)

The DMI (Dominance Indicator) activates or deactivates the dominance indicator in the surround sound field (white cross).

### 3.5.3 LPF

(Button/key 3, see Fig. 3-5)

The LPF (Low Pass Filter) function activates or deactivates the low pass filter function (300Hz) of the Surround Correlator. The current status is shown on the lower left in the SSA window.



Instrument Select  
 (see Chapter 3.3.2):  
 → MODE → VSC

Brief description in  
 Chapter 1.6.3

Focus on Window 3  
 (highlighted frame)



### 3.6 Functions of the VSC Instrument

- **Surround mode:**

(Please note: description of key labeling is marked with index Sur!)

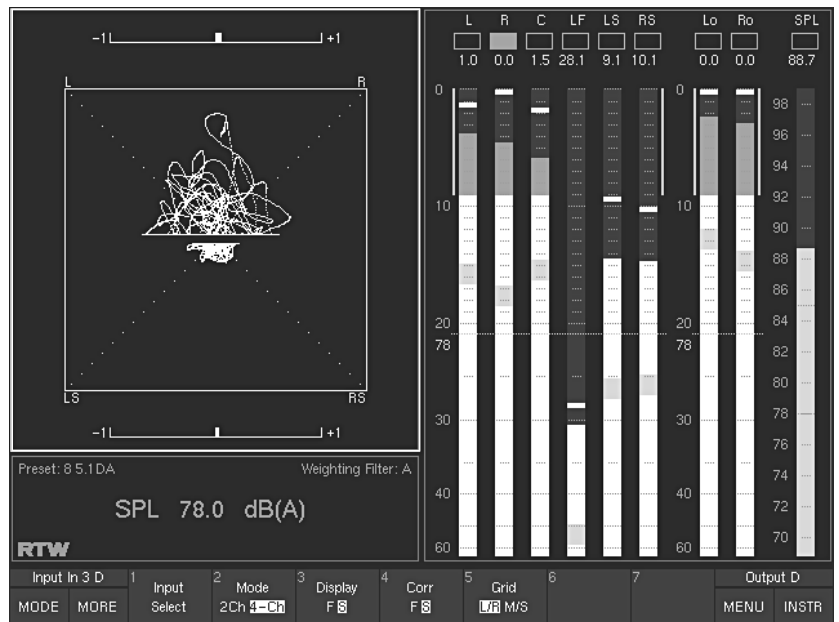

Fig. 3-6: Screen display with VSC instrument in Surround mode and 4-channel mode selected

- **2 Channel Stereo mode:**

(Please note: description of key labeling is marked with index 2Ch!)

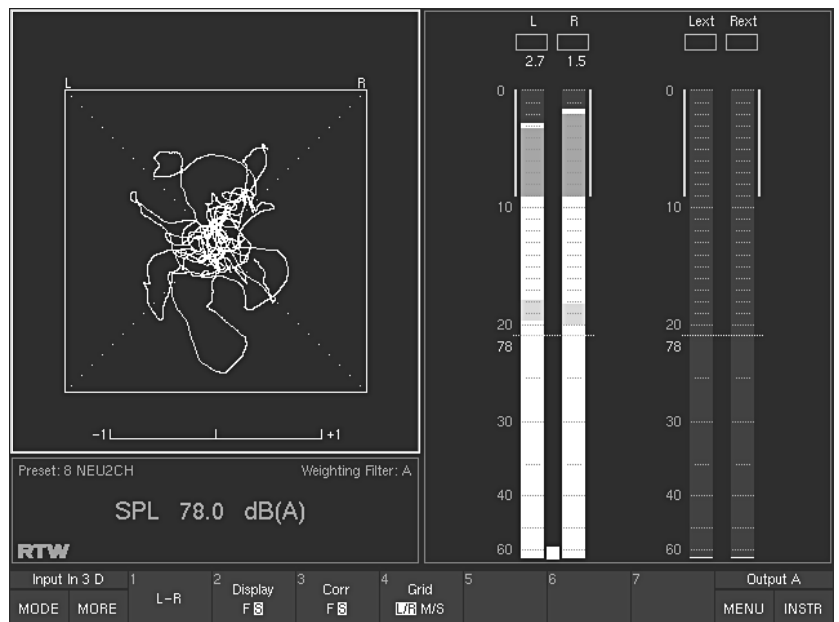

Fig. 3-7: Screen display with VSC instrument in 2 Channel Stereo mode selected

### 3.6.1 Input Select (Sur) – L - R (2Ch)

(in Surround mode: Input Select, button/key 1, see Fig. 3-6

in 2 Channel Stereo mode: L - R, button/key 1, see Fig. 3-7)

Depending on the selected mode the buttons/keys get a different labelling (compare Fig. 3-6 with Fig. 3-7).

- **Surround mode:**

Selecting this function displays an additional menu for selecting the inputs for the **two**-channel stereo vectorscope when 2-channel mode is selected (2 Ch, see Chapter 3.6.2):

- L – R (Button/key 1)
- LS – RS (Button/key 2)
- L – C (Button/key 3)
- C – R (Button/key 4)
- L – LS (Button/key 5)
- R – RS (Button/key 6)
- $L_0 - R_0$  resp.  $L_{ext} - R_{ext}$  (Button/key 7)

When you select a channel pair the Toolbar display will automatically switch back to the previous level. In 4-channel mode (4 Ch) this button/key has no function.

Also see Chapter 1.6.1 and Figs. 1-6 and 1-10



- **2 Channel Stereo Mode:**

In 2 Channel Stereo mode the button/key 1 is labeled L - R and displays the input channels L and R.

This function is **only** available in Surround mode!



### 3.6.2 Mode 2Ch/4Ch (Sur) – Lext - Rext (2Ch)

(in Surround mode: Mode, button/key 2, see Fig. 3-6)

- **Surround mode:**

The Mode function switches the vectorscope display between 2 and 4 channel mode (2Ch/4Ch).

In 4-channel mode channels L and R are represented in the upper half of the display, channels LS and RS in the lower half. The channel pairs L – R and LS – RS each have a correlation indicator. The Input Select function (see Chapter 3.6.1) is not available.

### 3.6.3 Display

(in Surround mode: button/key 3, see Fig. 3-6

in 2 Channel Stereo mode: button/key 2, see Fig. 3-7)

This function switches the display speed of the vectorscope between fast (F) and slow (S).

### 3.6.4 Corr

(in Surround mode: button/key 4, see Fig. 3-6

in 2 Channel Stereo mode: button/key 3, see Fig. 3-7)

This function switches the display speed of the correlator between fast (F) and slow (S).

### **3.6.5 Grid**

(in Surround mode: button/key 5, see Fig. 3-6

in 2 Channel Stereo mode: button/key 4, see Fig. 3-7)

This function switches the vectorscope grid between L/R (left/right) and M/S (middle/side).

Instrument Select  
 (see Chapter 3.3.2):  
 → MODE → COR

Brief description in  
 Chapter 1.6.4

Focus on Window 3  
 (highlighted frame)



### 3.7 Functions of the COR Instrument



- Surround mode

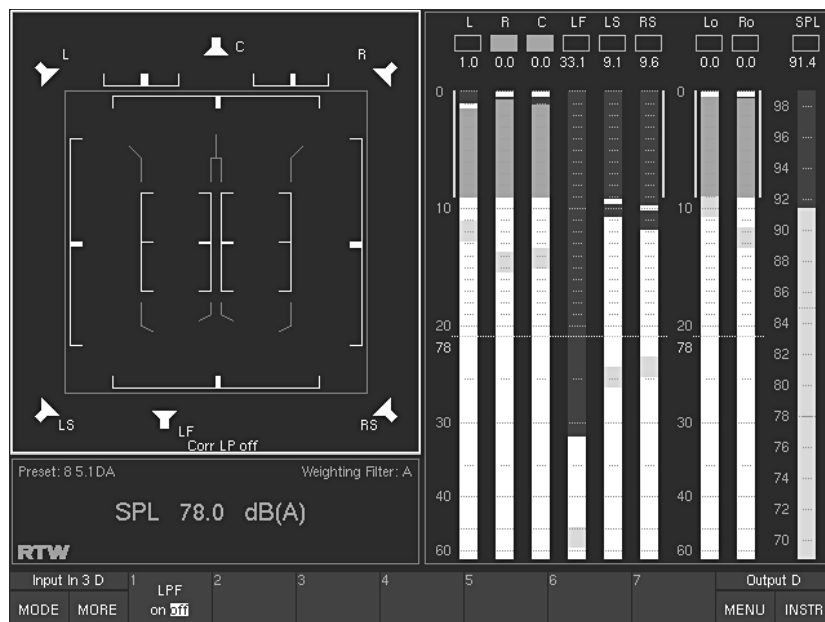

Fig. 3-8: Screen display with COR instrument in Surround mode selected

- 2 Channel Stereo mode

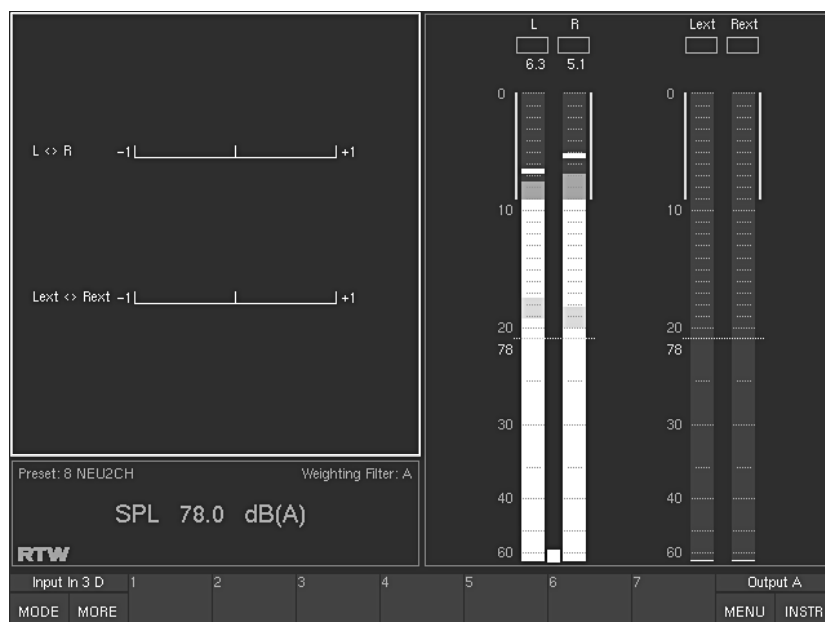

Fig. 3-9: Screen display with COR instrument in 2 Channel Stereo mode selected

See Fig. 3-8



- **Surround Mode**

In Surround mode the channel pairs of the surround channel combinations are displayed (see Fig. 3-8).

See Fig. 3-9



- **2 Channel Stereo Mode**

In 2 Channel Stereo mode channel pair L and R is displayed, also channel pair  $L_{ext}$  and  $R_{ext}$  when enabled (see Fig. 3-9).

This function is **only** available in Surround mode!



### 3.7.1 LPF

(Button/key 1, see Fig. 3-8, compare with Fig. 3-9)

The LPF (Low Pass Filter) function which is **only** available in Surround mode activates or deactivates the low pass filter (300 Hz) of the surround correlator. The current status is shown at the bottom left of the SSA window.

## 3.8 Functions of the RTA 1/3 and RTA 1/6 Instruments

### First function level:

Instrument Select  
(see Chapter 3.3.2):  
→ MODE → RTA 1/3

Brief description in  
Chapter 1.6.5

Focus on Window 3  
(highlighted frame),  
RTA 1/3 covers Window 4

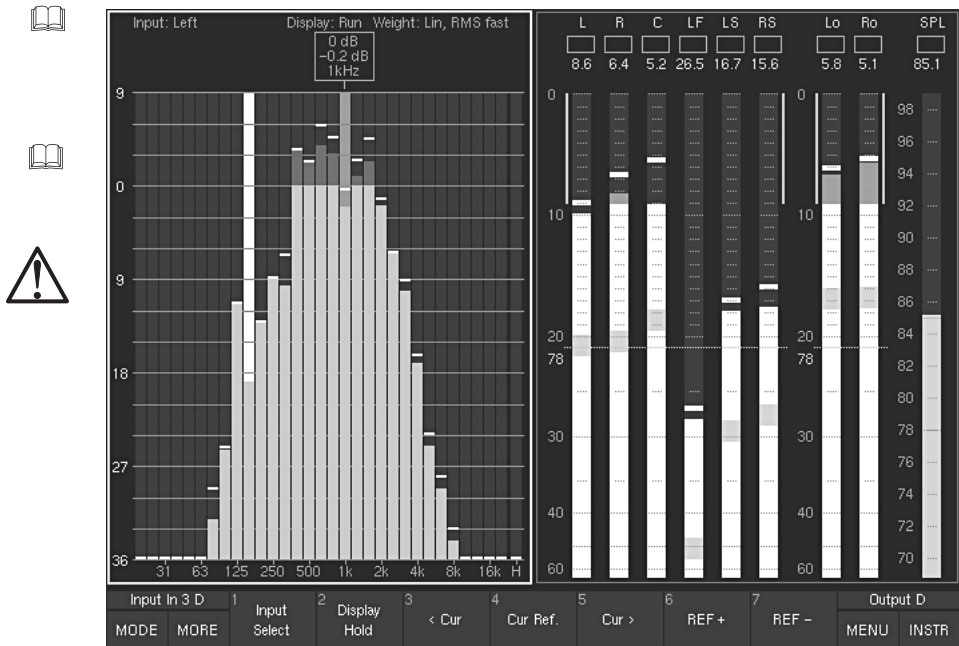

Fig. 3-10: First Toolbar function level of the RTA 1/3 instrument. Select MORE to display additional functions (level 2).

### First function level:

Instrument Select  
(See Chapter 3.3.2):  
→ MODE → RTA 1/6

Brief description in  
Chapter 1.6.6

Focus on Window 3  
(highlighted frame),  
„RTA 1/6“ covers  
Window 2 and Window 4

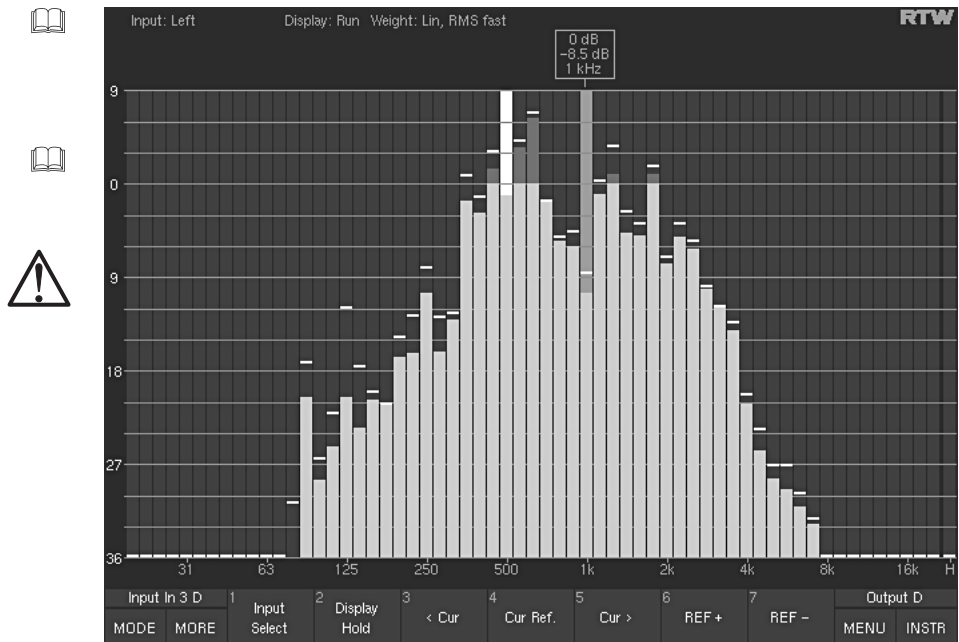

Fig. 3-11: First Toolbar function level of the RTA 1/6. Select MORE to display additional functions (level 2).

### 3.8.1 Input Select

(Button/key 1 – first level, see Figs. 3-10 and 3-11)

This function displays an additional Toolbar level where you can select the input signal sources:

Also see Chapter 4.4.6



#### • Surround mode:

- All w/o LF: All channels mixed, without LF, (Button/key 1)  
when selected in menu RTA Settings. Otherwise All is displayed here on the button and all channels including LF will be mixed and displayed in the RTA.
- Single: Opens an additional level for selection of a single channel. When you then select a channel the Toolbar will switch back to Function Select mode. (Button/key 2)
- Front: Sum of the front channels (Button/key 3)
- Rear: Sum of the surround channels (Button/key 4)
- L/R: Sum of L + R (Button/key 5)
- LF: LF channel (Button/key 6)

#### • 2 Channel Stereo mode:

- L/R: Sum of the channels L and R (Button/key 1)
- L: left channel L (Button/key 2)
- R: right channel R (Button/key 3)
- Lext/Rext: Sum of the external channels (Button/key 4)  
 $L_{ext}$  and  $R_{ext}$
- Lext: left external channel  $L_{ext}$  (Button/key 5)
- Rext: right external channel  $R_{ext}$  (Button/key 6)

### 3.8.2 Display Hold

(Button/key 2 – first level, see Fig. 3-10 and 3-11)

Selecting this function freezes the RTA display. A cursor readout is possible but the buttons/keys Ref+ and Ref- are disabled. This button/key has toggle function – select again to turn off Display Hold.

### 3.8.3 < Cur and Cur >

(Button/key 3 and button/key 5 – first level, see Figs. 3-10 and 3-11)

These functions move the cursor to the previous or next frequency band in the RTA. You can also move the cursor to the left and right by clicking and dragging with the optional mouse.

### 3.8.4 Cur Ref

(Button/key 4 – first level, see Figs. 3-10 and 3-11)

Selecting this function sets the current level of the selected frequency band as the reference value. If you then set the cursor on another band the difference between this band and the reference value is shown in the cursor readout.

### 3.8.5 Ref + and Ref –

(Button/key 6 and button/key 7 – first level, see Fig. 3-10 and 3-11)

These functions enable you to shift the display's reference point for a clearer readout in the window. The RTA's level display is **always** relative.

→ MORE

**Second function level** (select MORE to activate):

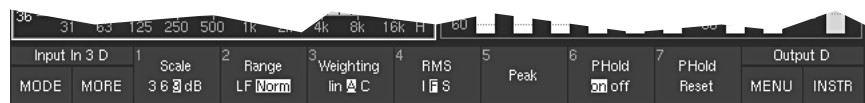

Fig. 3-12: Second Toolbar function level of the RTA 1/3 and RTA 1/6 instruments (displayed by selecting MORE)

### 3.8.6 Scale

(Button/key 1 – second level, see Fig. 3-12)

This function switches the display scale between 3 dB, 6 dB and 9 dB divisions.

### 3.8.7 Range

(Button/key 2 – second level, see Fig. 3-12)

This function switches the frequency range of the RTA display between LF (5 Hz – 5 kHz) and Norm (20 Hz – 20 kHz).

### 3.8.8 Weighting

(Button/key 3 – second level, see Fig. 3-12)

This function allows you to select weighting filter A or C. Selecting lin (linear) deactivates the weighting filters.

### 3.8.9 RMS

(Button/key 4 – second level, see Fig. 3-12)

This function (toggle function linked to button/key 5 – Peak) changes the integration time of the RTA display's RMS detector, as follows:

- I: Impulse
- S: Slow
- F: Fast (corresponds to IEC standard)



### **3.8.10 Peak**

(Button/key 5 – second level, see Fig. 3-12)

This function (toggle function linked to button/key 4 RMS) switches the display between peak integration with 10 ms and RMS integration.

### **3.8.11 PHold**

(Button/key 6 – second level, see Fig. 3-12)

This function switches the peak hold display on or off.

### **3.8.12 PHold Reset**

(Button/key 7 – second level, see Fig. 3-12)

This function clears the long-term memory, the peak hold memory and any stored digital errors.

Instrument Select  
 (see Chapter 3.3.2):  
 → MODE → DOWNMIX



## 3.9 Functions of the Downmix Instrument

Brief description in  
 Chapter 1.6.7



Focus on Window 3  
 (highlighted frame)



The Downmix instrument is  
**only** available in Surround  
 mode!

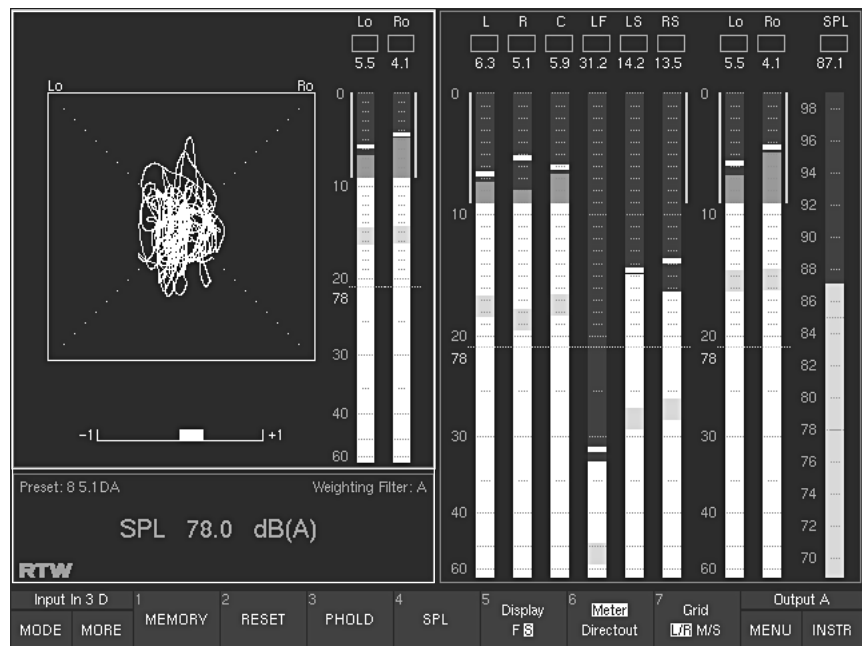

Fig. 3-13: Screen display with DOWNMIX instrument selected

Functions 3.9.1 to 3.9.5 all  
 apply only to the Downmix  
 Meter in Window 3.  
 None of these functions  
 have any effect on the  
 peakmeter displays in  
 Window 2!



### 3.9.1 Memory

(Button/key 1, see Fig. 3-13)

Depending on the current setting this function activates the numerical display of the long-term memory for maximum level, volume level, most negative correlation or digital errors.

### 3.9.2 Reset

(Button/key 2, see Fig. 3-13)

This function deletes the long-term memory, the peak hold memory and any stored digital errors.

### 3.9.3 PHold

(Button/key 3, see Fig. 3-13)

This function switches the peak hold display on or off.

### 3.9.4 SPL

(Button/key 4, see Fig. 3-13)

This function activates or deactivates the volume (sound pressure level) display.

### 3.9.5 Display

(Button/key 5, see Fig. 3-13)

This function switches the display speed of the vectorscope between fast (F) and slow (S).

### 3.9.6 Meter/Directout

(Button/key 6, see Fig. 3-13)

With this function the source for the display of the downmix signals can be selected:

- Meter: The signal source can be the analog or digital domain and the internal generated downmix signals are displayed. These signals cannot be routed to the outputs.
- Directout: The values of the internal generated downmix signals present on the digital output (see Fig. 2-3) are displayed.

See Fig. 2-3



### 3.9.7 Grid

(Button/key 7, see Fig. 3-13)

This function switches the vectorscope grid between L/R (left/right) and M/S (middle/side).

Instrument Select  
(see Chapter 3.3.2):  
→ MODE → MONITORING

Brief description in  
Chapter 1.7.1

Focus on Window 3  
(highlighted frame)



## 3.10 Functions of the Monitoring Instrument



**First function level:**

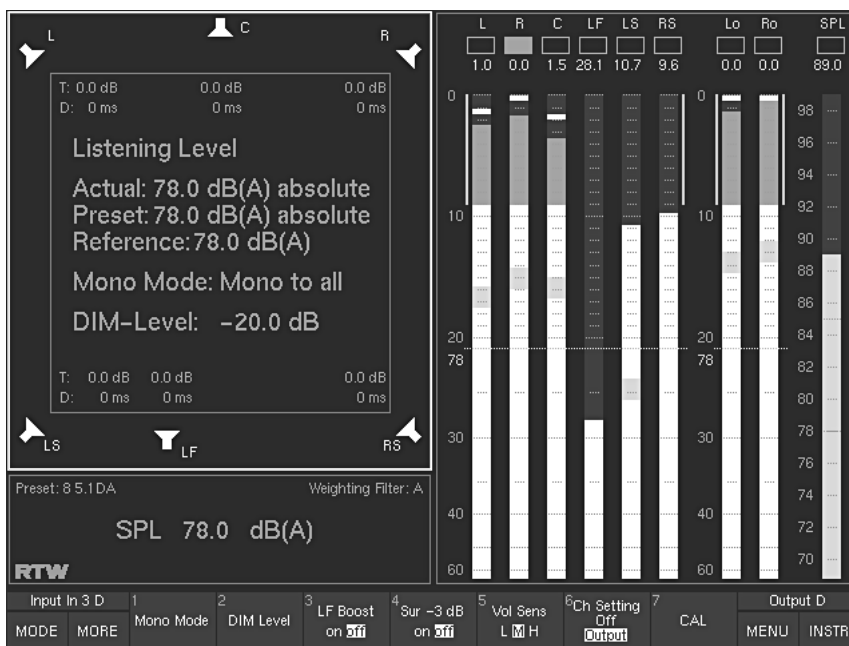

The controls of the Remote Control 30050 are described in detail in Chapter 3.15 (also see Chapter 1.7.2)

Fig. 3-14: First Toolbar function level of the MONITORING instrument. Select MORE to display additional functions (level 2).

Also see Chapter 3.15.10



### 3.10.1 Mono Mode

(Button/key 1 – first level, see Fig. 3-14)

This function enables you to select which loudspeaker you want to send the mono signal to when you press the M key on the Remote Control 30050 unit (see illustration on the left and Fig. 1-20 in Chapter 1.7.2). Selecting the function opens a second function level in the Toolbar with the following button/key assignments:



M key on the Remote Control 30050

- Centre (Button/key 1)
- L (Button/key 2)
- R (Button/key 3)
- L + R (Button/key 4)
- All (Button/key 5)
- Close (return to previous level) (Button/key 7)

The selection is activated immediately. After you make your selection the Toolbar remains displayed to allow you to compare the effects of different settings. You must select button/key 7 Close to switch back to the previous function level.

Also see Chapter 3.15.13



### 3.10.2 DIM Level

(Button/key 2 – first level, see Fig. 3-14)



DIM key on the Remote Control 30050

This function is used to set the amount of dimming (level attenuation) applied when you press the DIM key on the Remote Control 30050 (see illustration on the left and Fig. 1-20 in Chapter 1.7.2) or by an external control signal. Selecting the function opens a second function level in the Toolbar with the following button/key assignments:

- +10 dB (Button/key 1)
- +1 dB (Button/key 2)
- -1 dB (Button/key 3)
- -10 dB (Button/key 4)

Pressing button/key 1 through 4 increases or decreases the setting by the corresponding value. The result is displayed in Window 3. Activating the Mute function (button/key 5) switches the display off.

- Mute: When the DIM key on the Remote Control 30050 unit is pressed the Monitoring Controller's output signal is muted. (Button/key 5)
- Moment: Defines the switching behaviour of the DIM key on the Remote Control 30050 unit: (Button/key 6)
  - On: The DIM function only remains active while the DIM key on the Remote Control 30050 is pressed.
  - Off: Pressing DIM on the Remote Control 30050 switches the DIM function on or off. The current status is indicated by the light in the key.
- Close: Returns you to the previous Toolbar function level. (Button/key 7)

### 3.10.3 LF Boost

(Button/key 3 – first level, see Fig. 3-14)

This function boosts the output level of the LF channel by 10 dB (SMPTE Rec). This does not have any effect on the peak meter displays.

### 3.10.4 Sur -3 dB

(Button/key 4 – first level, see Fig. 3-14)

This function reduces the level of the surround channels by 3 dB (SMPTE recommendation for Mono Surround).

Also see Chapter 3.15.11



### 3.10.5 Vol Sens

(Button/key 5 – first level, see Fig. 3-14)

This function adjusts the sensitivity of the volume dial on the Remote Control 30050 unit:

- L: Low
- M: Medium
- H: High

### 3.10.6 Ch Setting

(Button/key 6 – first level, see Fig. 3-14)

This function sets the display mode for the trim and delay values:

- Off: No display
- Output: Shows the values set for the outputs

Detailed description in Chapter 3.11, (also see Chapter 1.7.1.1)



### 3.10.7 Cal

(Button/key 7 – first level)

This function activates the CAL instrument for calibration of the monitoring functions (see Chapter 3.11 for a detailed description).

→ MORE

**Second function level** (select MORE to activate):



Fig. 3-15: Second Toolbar function level of the MONITORING instrument (displayed by selecting MORE)

Also see Chapter 3.15.1



### 3.10.8 Level

(Button/key 1 – second level, see Fig. 3-15)

This function switches the listening level displayed on the Remote Control 30050 unit between absolute and relative (in relation to the set reference value). The current mode is indicated by the decimal point of the rightmost digit on the Remote Control 30050 display (see illustration on the left and Fig. 1-20 in Chapter 1.7.2).

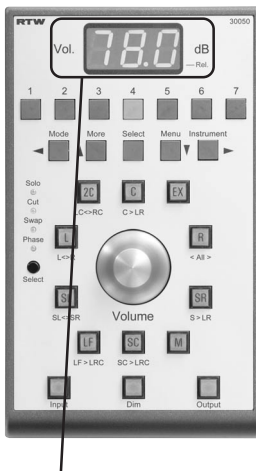

Display on the Remote Control 30050

See Chapter 3.10.7,  
 (also Chapter 1.7.1.1)  
 → MODE → MONITORING  
 → CAL



## 3.11 Functions of the Cal Instrument

The signal form and level are selected with the function keys. Switching the test signal to the desired outputs is easiest with the channel keys on the Remote Control 30050 unit. When you activate the CAL instrument all loudspeakers are automatically muted (indicated by red speaker symbols in Window 3). The default test signal is pink noise with a bandwidth of 20 Hz – 20 kHz and a level of –18 dB FS RMS. The SPL meter is displayed in Window 2 and the calibration microphone input is active.

Focus on Window 3  
 (highlighted frame)



### First function level:



Fig. 3-16: First Toolbar function level of the CAL instrument. Select MORE to display additional functions (level 2).

Also see Chapter 3.15.14



### 3.11.1 Trim

(Button/key 1 – first level, see Fig. 3-16)

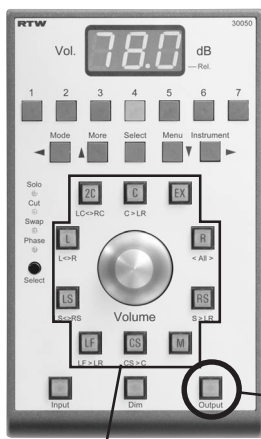

Channel keys and volume dial  
 on the Remote Control 30050

The Trim function allows you to adjust the levels of individual speaker channels to accommodate the acoustic properties of the listening room. To select the channel or channels for which you want to adjust the trim values press the corresponding keys on the Remote Control 30050 unit (see illustration on the left and Fig. 1-20 in Chapter 1.7.2). You can then adjust the trim value for the selected channel(s) by holding down the Trim key (button/key 1) and simultaneously turning the Volume dial on the Remote Control 30050. Trim values also can be set on the Audio System menu tab (see Chapter 4.7).

You can set different trim values for the analog and digital outputs. The output is selected with the Output key on the Remote Control 30050 unit or by clicking the corresponding button in the Toolbar (see Fig. 3-2 in Chapter 3.2) with the optional mouse.

### 3.11.2 Delay

(Button/key 2 – first level, see Fig. 3-16)

The Delay function allows you to adjust the delay applied to the individual loudspeaker channels to accommodate the acoustic properties of the listening room.

When you select cm as the units for setting the delay (see Delay Unit, Chapter 3.11.3 below) the left front speaker (L) is used as the reference point. Loudspeaker positioning according to the ITU standard is assumed as the basis. Deviations from this ideal circle can be set for all loudspeaker positions as positive (larger) and negative (smaller) distance values in cm. When you select ms as the units for setting the delay (see Delay Unit, Chapter 3.11.3 below) you can set individual time delay values for all speaker channels.

Also see Chapter 3.15.14



Channel keys and volume dial on the Remote Control 30050

Output key

To select one or more channels to adjust press the corresponding keys on the Remote Control 30050 (see illustration on the left and Fig. 1-20 in Chapter 1.7.2). You can then adjust the delay value for the selected channel(s) by holding down the Delay key (button/key 2) and simultaneously turning the Volume dial on the Remote Control 30050 resp. by setting them on the Audio System menu tab (see Chapter 4.7).

You can set different delay values for the analog and digital outputs. The output is selected with the Output key on the Remote Control 30050 or by clicking the corresponding button in the Toolbar (see Fig. 3-2 in Chapter 3.2) with the optional mouse.

### 3.11.3 Delay Unit

(Button/key 3 – first level, see Fig. 3-16)

This function sets the units for the delay setting:

- cm: Deviation of the loudspeaker's position from the ITU ideal position in cm
- ms: Allows you to set the desired delay individually for each channel

You can enter both negative and positive values for the distance delay:

- Entering positive values delays the selected channel and moves it back acoustically.
- Entering negative values leaves the selected channel unchanged and applies the select delay value to all the other channels (compare with the displayed values in the Audio System menu tab, description see Chapter 4.7). This delays all channels except the selected channel, thus moving the selected channel forward acoustically.

**Caution!** This can cause synchronisation problems with sound that is synced to the picture!



**Important!** Always allow for the standard delays applied to the signal by the SurroundControl 30900(-24) according to the selected mode and sampling frequency, as shown in the table!



Delay	Digital to Digital	Digital to Analog	Analog to Digital	Analog to Analog
<b>Delay in Frames:</b>				
	9	54	73	118
<b>Sampling Frequency</b>	<b>Delay in ms</b>			
44.1 kHz	0.2043	1.2258	1.6571	2.6786
48 kHz	0.1872	1.1232	1.5184	2.4544
96 kHz	0.0936	0.5616	0.7592	1.2272



### 3.11.4 Next Cha

(Button/key 4 – first level, see Fig. 3-16)

This function switches the test signal to the next channel (all other channels are muted). If no channel is currently active the sequence begins with channel L. Switching is performed clockwise.

### 3.11.5 All

(Button/key 5 – first level, see Fig. 3-16)

This function selects the test signal configuration for all speakers as follows:

- Off: Switches the test signal off
- On: Switches the test signal to all outputs including LF
- w/o LF: Switches the test signal to all outputs except LF

Detailed description in Chapter 3.12



### 3.11.6 Signal Select

(Button/key 6 – first level, see Fig. 3-16)

This function opens a new Toolbar function level with the functions of the test signal generator (see Chapter 3.12 for a detailed description).

### 3.11.7 Close

(Button/key 7 – first level, see Fig. 3-16)

This function closes the CAL instrument and returns you to the Monitoring instrument, resetting the loudspeaker channels to their normal mode and switching off the test signal generator.

→ MORE

**Second function level** (select More to activate):

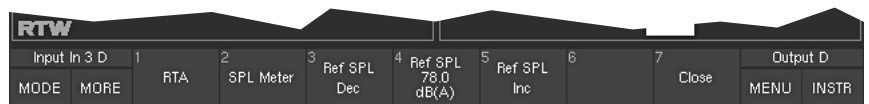

Fig. 3-17: Second Toolbar function level of the CAL instrument (displayed by selecting MORE)

Also see Chapter 1.7.1.1 and 3.8



### 3.11.8 RTA

(Button/key 1 – second level, see Fig. 3-17)

This function opens the RTA 1/6 instrument (the input of which is automatically assigned to the calibration microphone input in this mode) so that you can view the spectrum of the signal input by the microphone. You can use all the functions of the RTA 1/6 instrument (see Chapter 3.8). Selecting the Meter button/key in the Toolbar of the RTA 1/6 instrument takes you back to the first function level of the CAL instrument. Selecting the button/key MORE displays the second-level functions again.

### 3.11.9 SPL Meter

(Button/key 2 – second level, see Fig. 3-17)

This function opens an additional function level with controls for the SPL Meter functions.

- **Weighting**

(Button/key 1)

This function allows you to select the A or C weighting filters. Selecting lin (linear mode) switches the weighting filters off.

- **Response**

(Button/key 2)

This function switches the integration time between fast (F, 125 ms) and slow (S, 1 s) in accordance with the IEC 651 standard.

- **Microphone Select**

(Button/key 4)

This function allows you to select the calibration microphone type:

- MM-1: Calibration microphone MM 1, 15 mV/Pa (beyerdynamic)
- ECM: ECM 8000 (Behringer)

In order to prevent measurement errors there is no facility for entering microphone sensitivity values manually.

- **Phantom**

(Button/key 5)

This function switches the 48V phantom power supply on or off.

- **Range**

(Button/key 6)

This function sets the measurement range:

- L (low): 50 – 80 dB SPL
- M (medium): 70 – 100 dB SPL
- H (high): 90 – 120 dB SPL

- **Close**

(Button/key 7)

This function closes the second function level, leaving the SPL instrument active and returning you to the first function level. To redisplay the second level so that you can access the additional functions again just use the button/key MORE.

### **3.11.10 Ref SPL Dec**

(Button/key 3 – second level, see Fig. 3-17)

This function (Decrement) reduces the current SPL reference value (Ref SPL, see Chapter 3.11.11 below) in 1 dB steps.

### **3.11.11 Ref SPL**

(Button/key 4 – second level, see Fig. 3-17)

This function displays the SPL reference value set with button/key 3 Ref SPL Dec (Chapter 3.11.10) and button/key 5 Ref SPL Inc (Chapter 3.11.12).

### **3.11.12 Ref SPL Inc**

(Button/key 5 – second level, see Fig. 3-17)

This function (Increment) increases the current SPL reference value (Ref SPL, see Chapter 3.11.11 above) in 1 dB steps.

### **3.11.13 Close**

(Button/key 7 – second level, see Fig. 3-17)

This function closes the CAL instrument and returns you to the Monitoring instrument, resetting the loudspeaker channels to their normal mode and switching off the test signal generator.

See Chapter 3.11.6  
 and Fig. 3-16  
 → MODE → MONITORING  
 → CAL → Signal Select



## 3.12 The Cal Instrument's Signal Select Functions (Monitoring)

Selecting Signal Select (button/key 6 in the CAL instrument, see Fig. 3-16 in Chapter 3.11) opens a new function level containing the controls for the functions of the test signal generator:

Focus on Window 3  
 (highlighted frame)

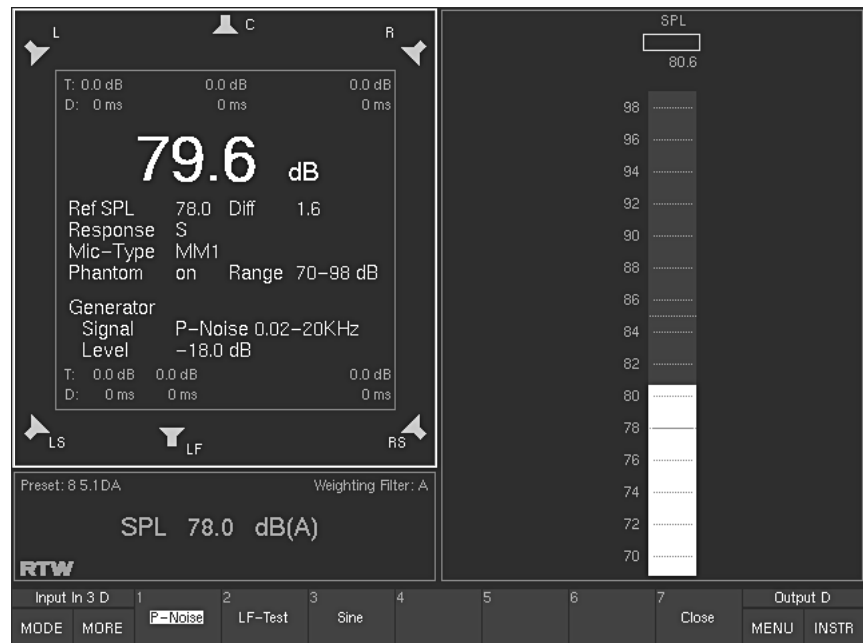

Fig. 3-18: Screen display after selecting "Signal Select" in the CAL instrument

The test signal generator can produce three different signal types:

- P-Noise: Generates a pink noise test signal. (See Chapter 3.12.1)
- LF-Test: The LF-Test function is used for a listening check of the balance between the subwoofer and the other speakers in accordance with the SSF proposal. (See Chapter 3.12.2)
- Sine: The Sine function generates a sine wave signal with an adjustable frequency and level. (See Chapter 3.12.3)

Selecting one of these functions automatically displays a new function level with the settings for the selected signal type. The level value is a common parameter that is applied for all test signal types, irrespective of which of the three buttons/keys you select to set it.

Buttons/keys 1 – 4 in the respective settings levels thus have the same labels and functions for all three test signal types:

- **Level**

(Button/key 1 – toggle function linked to Level Var)

See Chapter 4.8.



This function sets the selected level in dB FS RMS. You can adjust three values in the Reference Levels menu.

Factory settings:

- –9 dB FS RMS: Maximum allowed signal level pursuant to EBU, 0 dB on the peak meter (LMPSSL) (+6 dBu)
- –18 dB FS RMS: EBU adjustment level (–3 dBu)
- –20 dB FS RMS

- **Dec**

(Button/key 2 – Decrement)

This function reduces the variable output signal level (Level Var) in 1 dB steps.

- **Level Var**

(Button/key 3 – toggle function linked to Level)

This function selects the variable output signal level set with the buttons/keys 3 (Dec) and 4 (Inc).

- **Inc**

(Button/key 4 – Increment)

This function increases the variable output level (Level Var) in 1 dB steps.

### 3.12.1 P-Noise

(Button/key 1 – first level, see Fig. 3-18)



Fig. 3-19: Toolbar function level of the P-NOISE instrument

Selecting this function opens a new level with the following functions for setting the signal parameters:

- Level (button/key 1, see description above)
- Dec (button/key 2, see description above)
- Level Var (button/key 3, see description above)
- Inc (button/key 4, see description above)

- **Bandwidth**

(Button/key 5, see Fig. 3-19)

This function sets the bandwidth of the pink noise signal:  
0.2 kHz – 20 kHz or 20 Hz – 20 kHz.

- **Cor/Incor**

(Button/key 6, see Fig. 3-19)

This function switches all channels between coherent and incoherent noise.

- **Close**

(Button/key 7, see Fig. 3-19)

This function stores your settings and closes the current function level. The test signal generator remains active and the test signal remains on.

### 3.12.2 LF-Test

(Button/key 2 – first level, see Fig. 3-18)

Selecting this function displays a new function level with the functions for setting the LF test signal parameters.

When you perform the test by selecting the corresponding function (see below) a low-frequency signal (second level, see Fig. 3-21) is output to the LF channel and all other speakers are muted. When you select the same function again the noise signal with the bandwidth shown in the bottom row is output to the speakers set with the Output function (see below). Switching back and forth between the two allows you to check the balance of the crossover frequencies and the best position for the subwoofer.

#### First function level:



Fig. 3-20: First Toolbar function level of the LF-TEST instrument. Select MORE to display additional functions (level 2).

- Level (button/key 1 – first level, see above)
- Dec(button/key 2 – first level, see above)
- Level Var (button/key 3 – first level, see above)
- Inc (button/key 4 – first level, see above)

#### • Output

(Button/key 5 – first level, see Fig. 3-20)

This function selects the channels to which the surround test signal will be output:

- All: All channels (except subwoofer)
- LCR: Front channels L, R, C only
- LR: Channels L and R only

#### • Close

(Button/key 7 – first level, see Fig. 3-20)

This function stores your settings and closes the current function level. The test signal generator remains active and the test signal remains on.

→ MORE

### Second function level (select More to activate):



Fig. 3-21: Second Toolbar function level of the LF-TEST instrument (displayed by selecting MORE)

#### • **Bandwidth**

(Buttons/keys 1 to 5 – second level, see Fig. 3-21)

These functions select the bandwidth and output of the test signal.

- The upper value is activated the first time you select the function. The signal is then routed to the LF channel and all other channels are muted.
- The lower value is activated when you select the function a second time. The signal is then routed to the channels set with the Output function (button/key 5 – previous level, see above and Fig. 3-20). When All is selected all channels including the LF are activated. When LCR or LR are activated the LF channel is muted.

Values (in Hz):

- 25 – 50  
125 – 250: (button/key 1 – second level)
- 31.5 – 63  
160 – 320: (button/key 2 – second level)
- 40 – 80  
200 – 400: (button/key 3 – second level)
- 50 – 100  
250 – 500: (button/key 4 – second level)
- 63 – 125  
315 – 630: (button/key 5 – second level)
- 25 – 120  
off: (button/key 6 – second level)

The off function switches off the LF test signal.

The current function level remains open, so that you can reposition the subwoofer.

#### • **Close**

(Button/key 7 – second level, see Fig. 3-21)

Selecting this function ends the LF test.



The output levels of the sine wave generator are limited by default to prevent damage to the monitoring system.

If necessary you can deactivate the limiter in the Reference Levels menu (also see Chapter 4.8.).



### 3.12.3 Sine

(Button/key 2 – first level, see Fig. 3-18)

Selecting this function opens a new level with functions for setting the sine signal parameters.

#### First function level:



Fig. 3-22: First Toolbar function level of the SINE instrument. Select MORE to display additional functions (level 2).

The functions in this level allow you to set the frequency and level of the sine wave test signal:

- Level (button/key 1 – first level, see above)
- Dec (button/key 2 – first level, see above)
- Level Var (button/key 3 – first level, see above)
- Inc (button/key 4 – first level, see above)

- **Close**

(Button/key 7 – first level, see Fig. 3-22)

This function stores your settings and closes the current function level. The test signal generator remains active and the test signal remains on.

→ MORE

#### Second function level (select More to activate):



Fig. 3-23: Second Toolbar function level of the SINE instrument (displayed by selecting MORE)

- **Frequency selection functions (in Hz)**

(Buttons/keys 1 to 6 – second level, see Fig. 3-23)

- 20 – 25: (button/key 1 – second level)
- 50 – 100: (button/key 2 – second level)
- 250 – 500: (button/key 3 – second level)
- 1k – 2k: (button/key 4 – second level)
- 4k – 8k: (button/key 5 – second level)
- Off – 10k (button/key 6 – second level)

- **Close**

(Button/key 7 – second level, see Fig. 3-23)

This function stores your settings and closes the current function level. The test signal generator remains active and the test signal remains on.

Instrument Select  
 (See Chapter 3.3.2):  
 → MODE → MORE  
 → AES/EBU

Brief description in  
 Chapter 1.6.8

Focus on Window 3  
 (highlighted frame)



## 3.13 Functions of the AES/EBU Instrument

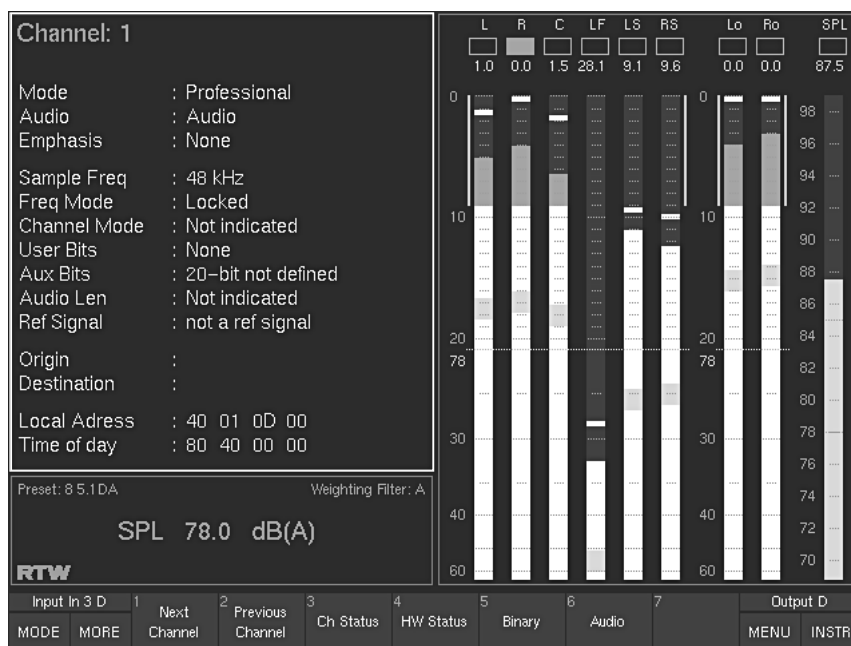

Fig. 3-24: Screen display with AES/EBU instrument selected

### 3.13.1 Next Channel and Previous Channel

(Buttons/keys 1 and 2, see Fig. 3-24)

These functions switch through the available input channels so that you can display and analyse the channel information with the instrument.

### 3.13.2 Ch Status

(Button/key 3, see Fig. 3-24 – toggle function linked to Binary)

This function switches the status information display to decoded plain text (Decoded Channel Status). The information displayed includes the origin and destination of the data (Origin, Destination), the CS block address (Local Adr.) and the block number (Time-Day). If no digital input signal is connected the message “Channel data not available” is displayed.

This function is displayed when you select the AES/EBU instrument.

### 3.13.3 HW Status

(Button/key 4, see Fig. 3-24)

Selecting this function displays the status of the AES/EBU receivers for all digital input sources and shows which digital input is currently being used as the source of the unit's clock signal. The internal sampling rate selected in the Audio System menu is used as clock signal if no digital signal is present at the digital inputs (see Chapter 4.7).

DigIn1 :	Ref	1.2	3.4	5.6	7.8
Status :	--	locked	locked	locked	locked
Reso :		24	24	24	24
-Bits :		24	24	24	24
DigIn2 :		1.2	3.4	5.6	7.8
Status :		--	--	--	--
Reso :					
-Bits :					

Legend:

locked: AES receiver has dubbed  
forced: Reference signal is only taken from this input  
--: There is no valid signal present

Sync Input : Dig1 -> 1.2  
Detected SampleFreq : 48000 Hz

Fig. 3-25: Screen display of Window 3 after selecting HW Status function

### 3.13.4 Binary

(Button/key 5, see Fig. 3-24 – toggle function linked to Ch Status)

Selecting this function activates the hex and binary display of channel status bytes 0 – 23 of the selected channel. If no digital input signal is connected the message “Channel data not available” is displayed.

Channel: 1

Byte 0-23 hex:

04	00	00	00	00	00	00	00
00	00	00	00	00	00	00	00
00	00	00	00	00	00	00	00

Byte 7.....0    Byte 7.....0    Byte 7.....0

0	00000100	8	00000000	16	00000000
1	00000000	9	00000000	17	00000000
2	00000000	10	00000000	18	00000000
3	00000000	11	00000000	19	00000000
4	00000000	12	00000000	20	00000000
5	00000000	13	00000000	21	00000000
6	00000000	14	00000000	22	00000000
7	00000000	15	00000000	23	00000000

Fig. 3-26: Screen display of Window 3 after selecting Binary function

### 3.13.5 Audio

(Button/key 6, see Fig. 3-24)

Selecting this function activates the audio display of the bit pattern of the current audio data and the active audio bits registered for the digital inputs.

Active Bits				Data Bits							
23 ->	16	15 ->	8	7 ->	0	23 ->	16	15 ->	8	7 ->	0
DigIn1				DigIn1							
xxxxxxx	xxxxxxx	xxxxxxx	xxxxxxx	L		00000011	01101111	10111100	L		
xxxxxxx	xxxxxxx	xxxxxxx	xxxxxxx	R		00000100	11010000	11000101	R		
xxxxxxx	xxxxxxx	xxxxxxx	xxxxxxx	C		00000100	11010000	11000101	C		
xxxxxxx	xxxxxxx	xxxxxxx	xxxxxxx	LF		00000100	11010000	11000101	LF		
xxxxxxx	xxxxxxx	xxxxxxx	xxxxxxx	LS		00000100	11010000	11000101	LS		
xxxxxxx	xxxxxxx	xxxxxxx	xxxxxxx	RS		00000100	11010000	11000101	RS		
xxxxxxx	xxxxxxx	xxxxxxx	xxxxxxx	Lext		00000100	11010000	11000101	Lext		
xxxxxxx	xxxxxxx	xxxxxxx	xxxxxxx	Rext		00000100	11010000	11000101	Rext		
DigIn2				DigIn2							
.....	.....	.....	.....	unused		.....	.....	.....	unused		
.....	.....	.....	.....	unused		.....	.....	.....	unused		
.....	.....	.....	.....	unused		.....	.....	.....	unused		
.....	.....	.....	.....	unused		.....	.....	.....	unused		
.....	.....	.....	.....	unused		.....	.....	.....	unused		
.....	.....	.....	.....	unused		.....	.....	.....	unused		
.....	.....	.....	.....	unused		.....	.....	.....	unused		
.....	.....	.....	.....	unused		.....	.....	.....	unused		

Fig. 3-27: The left screen display of Window 3 is shown after selecting Audio function. Selecting the Audio function again will show the right screen display in Window 3.

Instrument Select  
 (See Chapter 3.3.2):  
 → MODE → MORE  
 → DIALNORM

Brief description in  
 Chapter 1.6.9

Focus on Window 3  
 (highlighted frame)

The Dialnorm instrument is  
**only** available in Surround  
 mode and **only** available  
 for **digital** input signals!



## 3.14 Functions of the Dialnorm Instrument

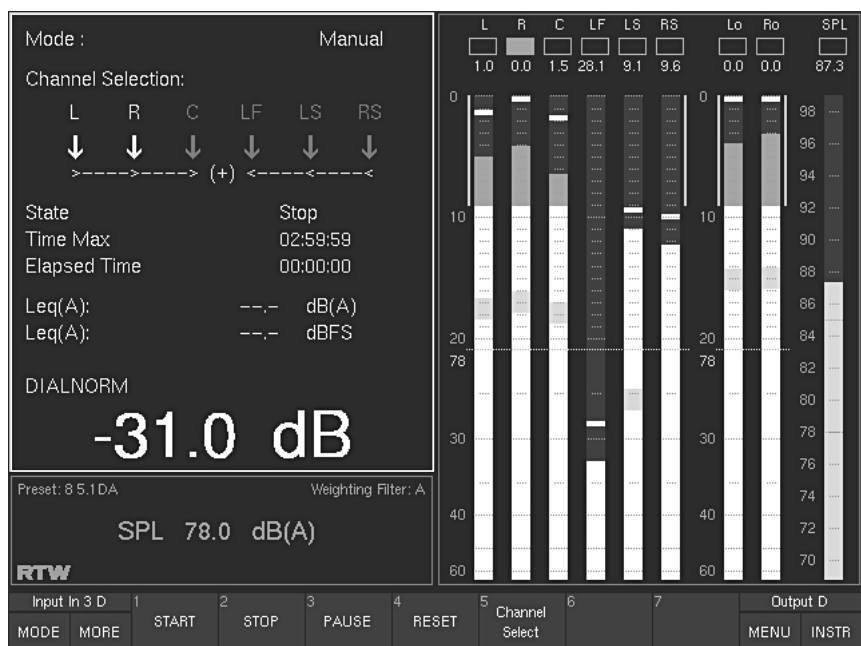

Fig. 3-28: Screen display with DIALNORM instrument selected

### 3.14.1 Start

(Button/key 1, see Fig. 3-28)

Selecting this function starts the Dialnorm measurement. The colour of the displayed values changes to green.

### 3.14.2 Stop

(Button/key 2, see Fig. 3-28)

Selecting this function ends the measurement. The colour of the displayed values changes to yellow.

### 3.14.3 Pause

(Button/key 3, see Fig. 3-28)

Selecting this function interrupts the measurement temporarily. All previously recorded values are stored automatically and the colour of the displayed values changes to red. To restart and continue the measurement select button/key 1 Start (see Chapter 3.13.1).

### 3.14.4 Reset

(Button/key 4, see Fig. 3-28)

This function resets the time counter.

### 3.14.5 Channel Select

(Button/key 5, see Fig. 3-28)

Selecting this function opens a new level in which you can select the channels you want to include in a Dialnorm measurement. Selecting the buttons/keys activates the corresponding channels, selecting again deactivates them. Activated channels are highlighted in yellow in the display.

- L + R:           L and R channel pair together                   (Button/key 1)
- C:               Centre channel                                   (Button/key 2)
- LF:              LF channel                                       (Button/key 3)
- LS + RS:       LS and RS channel pair together       (Button/key 4)
  
- Close:          Terminates the selection and returns       (Button/key 7)  
                    you to the previous level

## 3.15 The Controls of the Remote Control 30050 Unit

See Chapter 1.5 and 1.7.2

 The Remote Control 30050 is the main control unit for the Monitoring Controller (see Chapters 1.5. and 1.7). It controls all the monitoring and metering functions of the SurroundControl 30900(-24).

### The controls:

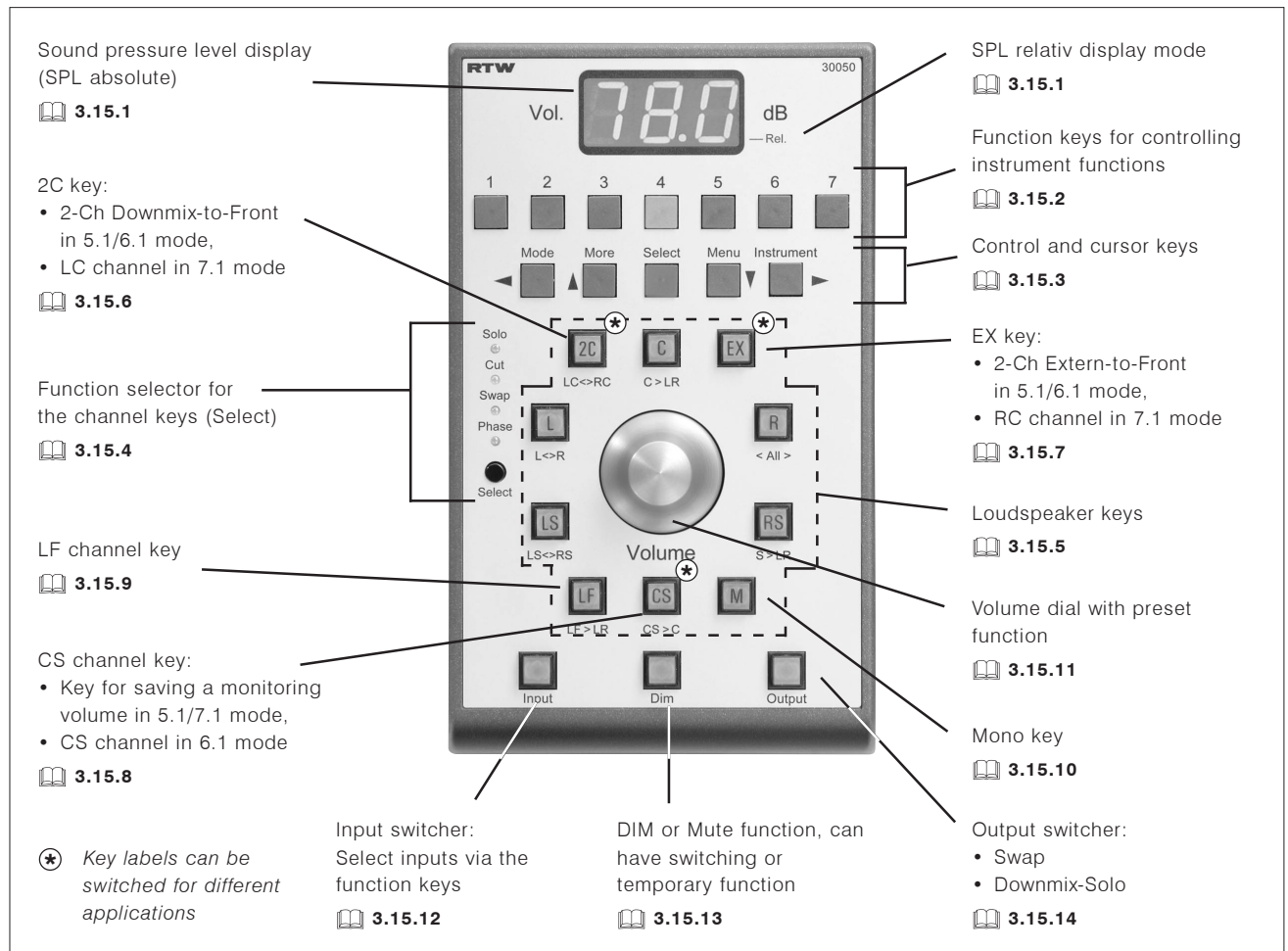



Fig. 3-29: The controls of the Remote Control 30050

### 3.15.1 The Monitoring Sound Pressure Level Display (SPL)

(See Figs. 3-29 and 3-1)

Also see Chapter 3.10.8

 There are two different modes for displaying the monitoring volume in the 8-digit 7-segment display:

- **SPL Absolute:** Displays the set equivalent listening sound pressure level in dB SPL(A). This is the sound pressure you would get if you applied a noise signal with a reference level to the input (e. g. -18 dB FS RMS).

- **SPL Relative:** Displays the attenuation or gain relative to the reference sound pressure level in dB. A display of 0 dB corresponds to your preset reference sound pressure level.

→ MODE → MONITORING  
 → MORE → LEVEL  
 (Also see Chapter 3.10.8)



You can select the display mode with the Monitoring instrument (see Chapter 3.10.8).

The decimal point of the rightmost digit on in the 7-segment display lights up when SPL Relative mode is active. When this decimal point is off this indicates that the display is in SPL Absolute mode.

The SPL display has three digits. In SPL Relative mode both positive and negative values are possible and the first digit of the 7-segment display is used for the sign. When values greater than  $\pm 9.9$  dB are displayed the scale switches automatically and the digit on the right displays the 1 dB values instead of the 1/10 dB values.

You can calibrate the connected monitoring system with the SurroundControl 30900(-24)'s integrated test signal generator and SPL Meter (see Chapters 3.11. and 3.12). You also need a calibration microphone which is available as an optional accessory.

### 3.15.2 The Function Keys

(See Fig. 3-29 and 3-1)

The functions assigned to function keys 1 – 7 change depending on the current instrument and operating mode. The currently active functions are always displayed in the Toolbar on the connected monitor (Remote Display 30010 or a standard VGA monitor). See Chapters 3.1 – 3.14 for detailed descriptions of the functions available in the individual instruments and modes.

### 3.15.3 The Control Keys and the Select Key

(See Figs. 3-29 and 3-1)

Also see Chapter 3.2. and 3.3.



→ MODE

- **MODE:** Switches between Function Select (select functions) and Instrument Select (select instruments) modes. The default mode is Function Select, which is also activated automatically as soon as you select an instrument.

→ MORE

- **MORE:** Displays the next Toolbar function level if additional functions are available. When you are on the last available level selecting MORE returns you to the first level. The text in the Toolbar buttons also changes to grey when no more levels are available.

→ SELECT

- **SELECT:** Used to terminate and confirm your inputs in the menus.

→ MENU

- **MENU:** Opens the menu pages for configuration of the system settings.

→ INSTRUMENT

- **INSTRUMENT:** Switches the focus between Window 2 (Peak Program Meter) and Window 3 (current instrument) – see Chapter 1.4 for details. The function keys always control the instrument that currently has the focus, which is indicated by the highlighted frame around the instrument.

In the configuration menus the control keys on the left and right of the Select key (in the middle) function as cursor keys.



### 3.15.4 Function Selector for the Channel Keys

(See Figs. 3-29 and 3-1)

The Select button on the left hand side of the Remote Control 30050 sets the current function of the channel keys, which is indicated by a yellow LED:

- Solo: Mutes all channels except the selected channel.
- Cut: Mutes the selected channel.
- Swap: Swaps channels as indicated by the blue labels on the panel beneath the keys (see Fig. 3-30)
- Phase: Rotates the phase of the selected channel by 180°. The corresponding loudspeaker symbol of the display changes to a lined symbol, the sign  $\wedge$  is added to the channel labelling.



These functions apply for keys with channel allocations, which correspond to the surround format you are currently using. Please note that depending on the surround format selected the 2C, EX and SC keys also can proceed as channel keys (see Chapters 3.15.5 – 3.15.10).

#### Swap Functions (blue labels on panel)

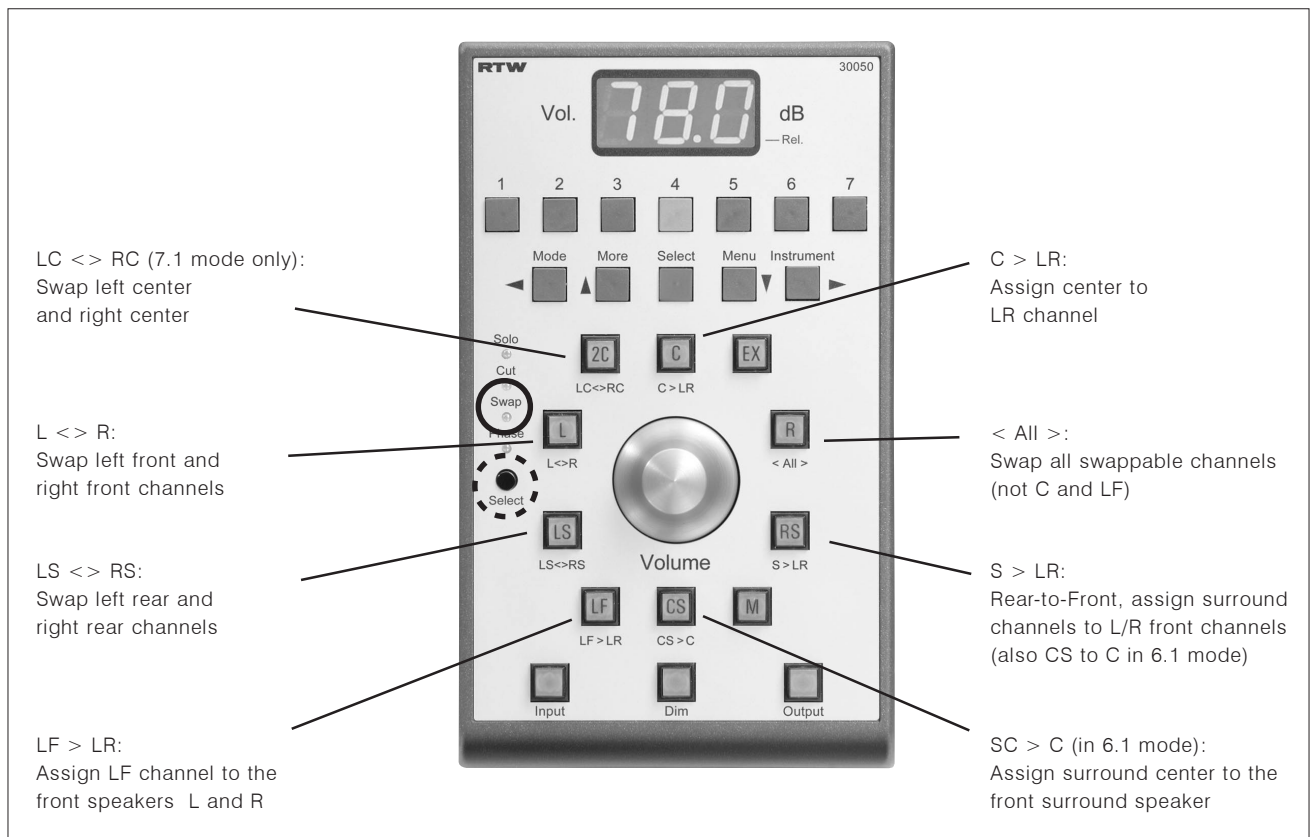

Fig. 3-30: Remote Control 30050 function key assignments in Swap mode (blue labels beneath the keys)

### 3.15.5 The Channel Keys

(See Figs. 3-29 and 3-1)

The channel keys control the channel functions of the loudspeaker outputs. The functions that can be performed by these keys (Solo, Cut, Swap, Phase) are set with the Select button (see 3.15.4) on the left side of the Remote Control 30050 unit. Some of the channel keys can have different functions in some surround formats (see Chapters 3.15.6 – 3.15.10).

### 3.15.6 The 2C Key

(See Figs. 3-29 and 3-1)

This key performs different functions depending on the current mode:

- 5.1/6.1 mode: Irrespective of the channel key function set with the Select button (see Chapter 3.15.4) pressing this key in these modes switches the internal  $L_0/R_0$  (VOL) (2-Ch Downmix) to the L and R front channels, and all other channels including LF are muted. The Swap (channel swap) and Phase (invert phase) functions can be performed with the L and R keys. In these modes the 2C key has a toggle function and is linked to the EX key (see Chapter 3.15.7).

In the Key Settings menu (see Chapter 4.12.3) you can configure the Downmix Meter (settings see Chapter 4.4.3) or the Surround Sound Analyzer (SSA) instrument to activate automatically when you switch to  $L_0/R_0$  Monitoring.

- 7.1 mode: In this mode this key is assigned to the Left Center (LC) channel. It enables you to apply the functions selected with the Select button on the left of the unit (see Chapter 3.15.4.) to the LC channel.

See Chapter 4.12.3 and 4.4.3



2C key cap can be changed with LC key cap included in standard package.

### 3.15.7 The EX Key

(See Figs. 3-29 and 3-1)

This key performs different functions depending on the current mode:

- 5.1/6.1 mode: Irrespective of the channel key function set with the Select button (see Chapter 3.15.4) pressing this key in these modes switches the external  $L_{ext}/R_{ext}$  (2-Ch Downmix) to the L and R front channels, and all other channels including LF are muted. The Swap (channel swap) and Phase (invert phase) functions can be performed with the L and R keys. In these modes the EX key has a toggle function and is linked to the 2C key (see Chapter 3.15.7). In the Key Settings menu (see Chapter 4.12.2) you can configure the Vectorscope (settings see Chapter 4.4.4) or the Surround Sound Analyzer instrument to activate automatically when you switch to  $L_{ext}/R_{ext}$  Monitoring.

In this mode this key is assigned to the Right Center (RC) channel. It enables you to assign the functions selected with the Select button on the left of the unit (see Chapter 3.15.4) to the RC channel.

See Chapter 4.12.2 and 4.4.4



EX key cap can be changed with RC key cap included in standard package.

### 3.15.8 The CS Channel Key

(See Figs. 3-29 and 3-1)

This key performs different functions depending on the current mode:

- 5.1/7.1 mode: Pressing the CS key in these modes stores the value of the current reference sound pressure level (SPL) setting as a preset. The value can then be displayed and activated at any time by pressing the Volume dial (see Chapter 3.15.11). The preset also remains stored when the SurroundControl 30900(-24) is switched off. This does not have an effect on the calibration of the monitoring system. This function is simply provided as a useful feature that allows you to return quickly to a stored volume level.
- 6.1 mode: In this mode the CS key is assigned to the Surround Centre channel (CS). It enables you to apply the functions selected with the Select button on the left of the unit (see Chapter 3.15.4.) to the SC channel.

### 3.15.9 The LF Channel Key

(See Figs. 3-29 and 3-1)

This key enables you to apply the functions selected with the Select button on the left of the unit (see Chapter 3.15.4.) to the subwoofer (LF) channel.

Also see Chapter 3.10.1



### 3.15.10 The Mono Key

(See Figs. 3-29 and 3-1)

Mono Mode:

- MODE → MONITORING
- MONO MODE

This key switches the mono signal to the channel selected with the Mono Mode function in the Monitoring instrument. The function selected in the Toolbar remains activated until you select button/key 7 Close. This enables you to check the effects of different settings. Window 4 (Status Box) then displays the message "Mono active".

Also see Chapter 3.10.5



### 3.15.11 The Volume Dial

(See Figs. 3-29 and 3-1)

Vol Sens:

- MODE → MONITORING
- Trim/Delay:
- MODE → MONITORING
- CAL

This dial adjusts the listening volume. You can set the sensitivity of the dial (Vol Sens) in the Monitoring instrument. The dial is also used in the CAL instrument for setting trim and delay values for individual channels, by holding down Trim or Delay and simultaneously turning the dial (see Chapters 3.11.1 and 3.11.2).

In 5.1 and 7.1 modes pressing the Volume dial retrieves and sets the preset value stored with the CS channel key (see Chapter 3.15.8). The Downmix-Direct-Out signals  $DL_0$ ,  $DR_0$  and  $DM_0$  are not affected by the volume dial setting.

See Chapter 4.12



When the Adding Mode, push volume knob for global reset option button is activated on the Key Settings menu tab (see Chapter 4.12) all channels can be set back to the basic position by pressing the volume dial.

### 3.15.12 The Input Key (input switcher)

(See Figs. 3-29 and 3-1)

This key selects the input for the Monitoring Controller. Pressing the key activates the display of the inputs on the buttons of the Toolbar (Window 1). With the corresponding buttons/keys (1 to 4) the input source can be selected. Pressing the Input key again switches back to the used instrument now with the selected input source.

Also see Chapter 3.10.2



### 3.15.13 The DIM Key

(See Figs. 3-29 and 3-1)

→ MODE → MONITORING

This key activates dimming (level attenuation), using the value set with the DIM Level function in the Monitoring instrument. Setting this value to minus infinity is equivalent to a Mute All function.

You can configure the behaviour of this key with the Monitoring instrument. The available options are Mute and Moment, which have the following functions:

- Mute off: Pressing the DIM key on the Remote Control 30050 activates dimming with the configured attenuation level value. Window 4 then displays: Monitor dimmed.
- Mute on: Pressing the DIM key on the Remote Control 30050 mutes the output signal. Window 4 then displays: Monitor muted.
- Moment on: The DIM/Mute function only remains active as long as you press the DIM key on the Remote Control 30050 unit.
- Moment off: Pressing the DIM key on the Remote Control 30050 switches the DIM/Mute function on or off. Current status is then indicated by the key light.

### 3.15.14 The Output Key (output switcher)

(See Figs. 3-29 and 3-1)

→ MODE → MONITORING

→ CAL

Also see Chapter 4.6 and 4.4.7



This key switches the output signal to the analog or digital outputs (see also Chapters 3.11.1 and 3.11.2). The output routing mode is set in the Input/Output Routing menu (Global Routing Settings, see Chapters 4.6 and 4.4.7 „Monitoring Output Mode“), as follows:

- Swap: The output signals are only sent to the active output, the other output is muted. This function is used when you have two monitoring systems.  
Example: The main monitoring system is connected to the digital output (display in the Toolbar: Output D) and an alternative “home system” is connected directly to the analog outputs via an amplifier (display in the Toolbar: Output A).
- Downmix-Solo: When you press the Output key the signals  $L_0/R_0$  are connected to the preselected outputs and all other outputs are muted.  
Example: You want to listen to the 2-Ch Downmix on separate loudspeakers in a near-field set. The Toolbar then displays Downmix A for analog and Downmix D for digital outputs.

## 3.16 Connecting several Remote Control 30050

Up to three Remote Control 30050 can be connected via Y cable to one main unit of a SurroundControl 30900(-24) (see Fig. 3-31). To assure a safe data transfer the Remote Controls have to be encoded with different addresses after the start-up of the system and before starting with work (see Chapter 3.16.1 and Fig. 3-31). The encoding has no influence on the functionality or the priority of the operating of one Remote Control (priority see Chapter 3.16.2).

### 3.16.1 Addressing

(see Fig. 3-31)



Delivered Remote Control 30050 are encoded to the **address 0** by factory. The address is shown at the display of the Remote Control (– – 0).

The Remote Control delivered with the SurroundControl 30900(-24) can be connected without any changes.

For the encoding of additional Remote Control 30050 first connect them to the main unit via y cable and then start-up the system.

Please proceed as follows:

- Press the DIM key of the second connected Remote Control and hold it down.
- Press key 2.
- Let off both keys. The second connected Remote Control now is encoded with **address 1** (– – 1 at the display on start-up).
- Press the DIM key of the third connected Remote Control and hold it down.
- Press key 3.
- Let off both keys. The third connected Remote Control now is encoded with **address 2** (– – 2 at the display on start-up).



	Addressing of the Remote Control 30050			
	Number:	①	②	③
	Maximum of 3 x to 30900	included in delivery, coded to: address <b>0</b>	address <b>1</b>	address <b>2</b>
	Short cut:	<b>DIM + 1</b>	<b>DIM + 2</b>	<b>DIM + 3</b>
	Note:	The address will be shown on start-up of the system. Delivered Remote Controls are coded to address <b>0</b> .		

Fig. 3-31: Connection and addressing of additional Remote Control 30050

### 3.16.2 Operating priority

The encoding has no influence on the priority of the operating sequence. The priority is configured as follows:

- If the same keys of the different Remote Controls are pressed nearly at the same time then the first pressed key takes priority over the other pressed keys.
- If the volume dials of the different Remote Controls are turned nearly at the same time then the first turned volume dial takes priority over the other turned dials. While the dial is moving the entries of the other ones are locked. After the entries are finished the lock is still hold for a short delay time. Then the entries of the other volume dials will be taken into account.



# 4 Menus

## 4.1 Introduction

→ MENU

The button/key MENU opens the start page (the menu tab shown in Fig. 4-1) for the Instrument Settings and the device or Global Settings(all the other tabs, see Fig. 4-1).

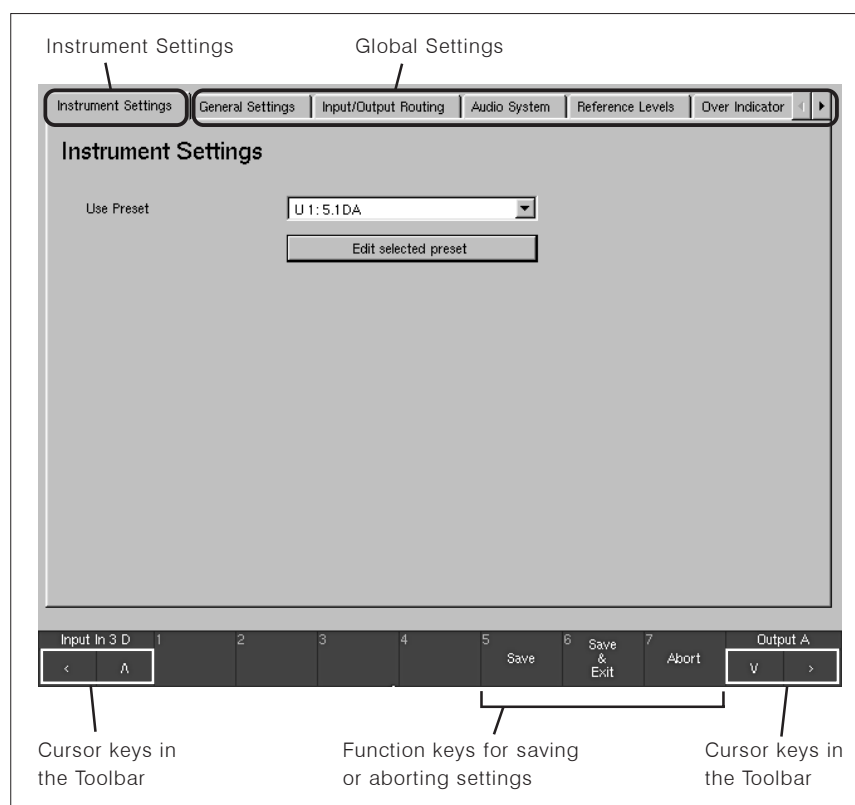

Fig. 4-1: Menu start page of the SurroundControl 30900(-24)

See Fig. 4-1 and Chapters 4.4, 4.13 and 4.14



**Instrument Settings** (see Fig. 4-1 and Chapters 4.4, 4.13 and 4.14)

This is where you can change the setting of the current preset (Edit selected preset) or select a different preset. An Instrument Setting stores the settings for all available instruments in a single preset. There are 14 editable user presets and 7 unchangeable factory presets (see Chapter 2.4).

If you install an optional computer mouse you can right-click in an instrument window to switch from the normal display mode to the menu of the instrument you click on. This displays the settings of the current preset. If this is a factory preset you will be prompted to save any changes in one of the 14 user presets when you exit the instrument menu. If you don't do this any changes made will be lost.

See Fig. 4-1 and Chapters 4.5 to 4.12



### **Global Settings** (see Fig. 4-1 and Chapters 4.5 to 4.12)

The global device settings are accessed with the other tabs in the menu, i.e. General Settings, Reference Levels and so on. Note that the Global Settings are stored separately from the Instrument Settings. There is always only one set of Global Settings, you cannot store different versions as you can for the user presets.

### **Saving settings**

You can save or discard changes to both the Instrument Settings and the Global Settings with the function keys/buttons in the Toolbar (see Chapter 3.1 and 3.2):

- **Save**

(Button/key 5, see Fig. 4-1)

Saves your settings without exiting the current page.

- **Save & Exit**

(Button/key 6, see Fig. 4-1)

Saves your settings and returns you to normal mode.

- **Abort**

(Button/key 7, see Fig. 4-1)

Discards all your changes and returns to normal mode without saving.

You can close every menu page with the Close button. When you do this any changes you have made are retained temporarily and can then be saved by selecting Save (button/key 5 in the Toolbar) or Save & Exit (button/key 6 in the Toolbar).

### **Navigating in the menus**

You can navigate through the menus with the control keys on the Remote Control 30050 or the Remote Display 30010, or by clicking on the buttons in the Toolbar with the optional mouse. In the menus the control keys have cursor functions (see Fig. 3-1):

→ <

- <: This button/key moves the cursor to the left or displays the previous menu page.

→ >

- >: This button/key moves the cursor to the right or displays the next menu page.

→ v

- v: This button shifts the focus to the next dialog element. Inside dialog boxes it moves to the next selection.

→ ^

- ^: This button shifts the focus to the previous dialog element. Inside dialog boxes it moves back to the previous selection.

→ SEL(ECT)

- Sel(ect): This button confirms the dialog element highlighted with the cursor keys (i.e. the element that currently has the focus), or changes its status by selecting or deselecting it.



## 4.2 Settings – Basic Principles

The following sections explain the basic principles of how the SurroundControl 30900(-24)'s settings work to make it easier to use the menus to configure your system.

### Internal channel organization and signal routing (see Fig. 4-2)

Internally, the SurroundControl 30900(-24) uses logical channels (L, R etc.) that match the selected surround format. For example, if you are using 5.1 surround the internal logical channels are L, R, C, LS, RS, LF, L<sub>ext</sub>, R<sub>ext</sub>, L<sub>0</sub> and R<sub>0</sub>. The assignment of the physical signal inputs to these logical channels is performed in the Input Routing, with separate settings for each input. Internally, the Metering and the Monitoring Controller of the SurroundControl 30900(-24) always use the logical channels (L, R etc.) and not the physical inputs. The same applies accordingly for the Monitoring Controller's outputs: The logical internal channels (L, R etc.) are routed to the physical outputs with settings in the Output Routing. You can enter different settings for the analog and digital outputs.

Input routing: See Chapter 4.6 and Fig. 4-16



Output routing: See Chapter 4.6 and Fig. 4-16

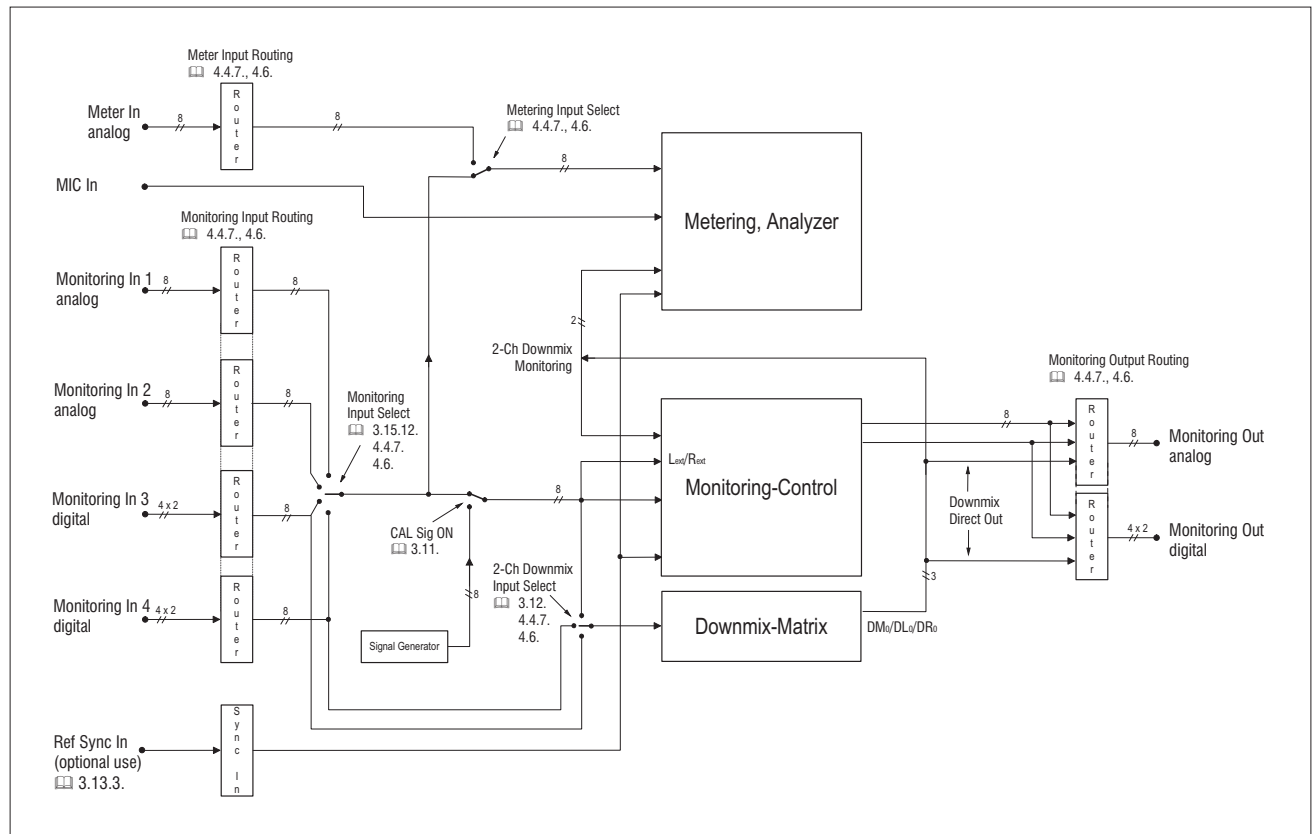

Fig. 4-2: Signal routing in the SurroundControl 30900(-24)

Global Routing Settings:  
See Chapter 4.6 and  
Fig. 4-16



### Routing in the Global Settings

These routing settings are normally only configured once when the system is set up in the studio and then not changed again. That is why they are called Global Routing Settings; they are also saved separately from the individual instrument presets.

Local Routing Settings:  
See Chapter 4.4.7 and  
Fig. 4-11



### Special case: Local routing settings in the Instrument Settings

There are some applications where you may want to use several different presets so that you can quickly configure the SurroundControl 30900(-24) for connection to different recorders, for example in mobile operation. In these special cases you can use individual presets to override the global settings with local settings. To do this select the Use Local Routing Settings check box in Instrument Settings menu/Edit Selected Preset button/General Presets menu. Note that selecting a preset in which the check box Use Local Routing Settings is not activated the SurroundControl 30900(-24) uses its global routing settings.

Setting: See Chapters 4.13,  
1.6.1 and Fig. 4-32



### The surround format setting



The surround format is **dictated by the peakmeter setting** (Instrument Settings menu/Edit Selected Preset button/Peakmeter menu/Channel Group 1 button/Mode Select combo box). For example, if you select a 7.1 format in the Peak Program Meter the SurroundControl activates the internal channels L, LC, C, RC, LS, RS and LF. These are then selected and adjusted with the channel keys and the volume control on the Remote Control 30050 unit.

### The Downmix Matrix

A stereo-compatible 2-channel signal is downmixed from the surround channels using adjustable factors. In 5.1 format the surround channels LS and RS are output to the left and right channels, and the Center channel is mixed into both channels with the same level on each side. It is advisable to apply an attenuation of 3 dB for the Center channel.

See Fig. 4-2



The SurroundControl 30900(-24) makes the 2-channel signal available as Downmix Direct Out (Routing Matrix designations: DL<sub>0</sub>, DR<sub>0</sub>, DM<sub>0</sub>) and Downmix Volume Out (VL<sub>0</sub>, VR<sub>0</sub>). The Direct Out signal is generated independently of all the channel functions and can be used for recording or as a parallel signal for transmission as a stereo broadcast. The Vol signal is used for monitoring and is thus routed via the Monitoring Controller. You can switch this signal to the L/R channels of the main monitoring system with the 2C key on the Remote Control 30050 (see Chapter 3.15.6 and Fig. 3-29). All other channels are then muted. Alternatively, you can switch the signal to your own outputs with the Output key, for example when you want to monitor it on your own loudspeaker system. The necessary settings are made in Input/Output Routing menu (Global Routing Settings/Monitoring Output Mode – see Chapter 4.6 and Fig. 4-16).

See Chapter 3.15.6  
and Fig. 3-29



See Chapter 4.6 and Fig. 4-13,  
also Chapter 4.4.7



### Downmix in 6.1 and 7.1 Format

The total number of input and output channels is limited to 8 per domain or group. Because of this there are a number of points you need to observe in connection with the downmix for 6.1 and 7.1 formats (see the section below for details).

### The $L_{ext}/R_{ext}$ channels

There are a number of points you need to observe when using the additional external channels, depending on the surround format. Since you have eight channels per domain 5.1 format is not a problem: the unit is able to manage the six surround channels and the two additional channels internally as a group. However, since the 6.1 and 7.1 formats require seven and eight inputs, respectively, it is not possible to configure the external channels in the same channel group. This is particularly important for the outputs, where the additional channels must be placed in the other domain (i.e. digital or analog). This can be configured in the Output Routing settings (see Chapter 4.6).

Example: 7.1 output analog; if you wish to use  $L_{ext}/R_{ext}$  (and possibly also  $L_0/R_0$ , see below) you must configure them in the digital domain.

### The $L_0/R_0$ channels

When the surround signal is mixed to form a stereo-compatible two-channel mix the internal channels  $L_0/R_0$  are generated in the internal downmix matrix. These channels can be displayed in a separate instrument (the Downmix Meter) in the left instrument window, which is Window 3 (level, SPL, correlation and audio vectorscope). You can also display the levels of channels  $L_0/R_0$  in the peakmeters. When the downmix matrix is activated these channels can be routed to the outputs as  $DL_0/DR_0$  (Direct Out) and they are independent of the volume control on the Remote Control 30050. In addition to these channels you also have the channels  $VL_0/VR_0$  (VOL), which are controlled by the volume control and can also be routed to the outputs for monitoring. The  $VL_0/VR_0$  channels also have a Solo function, which can switch the  $VL_0/VR_0$  signals either to separate outputs or to the front loudspeakers L and R, which then mutes all other channels. In practice this means you can monitor the 2-channel downmix either on the main monitors or on a second speaker set, for example on nearfield monitor speakers.

Downmix matrix: See  
Chapters 4.4.7 and 4.6  
(• Downmix and  
• Monitoring Output Mode)



Global Routing Settings:  
See Chapter 4.6 and  
Fig. 4-16



### Routing configuration

The routing settings described above can be configured with the Meter Input Routing, Monitor Input Routing and Monitor Output Routing buttons in the Input/Output Routing menu (Global Routing Settings – see Chapter 4.6). All routing settings can be configured **independently** for the surround formats 5.1, 6.1 and 7.1.



# 4.3 Menu Structure Reference

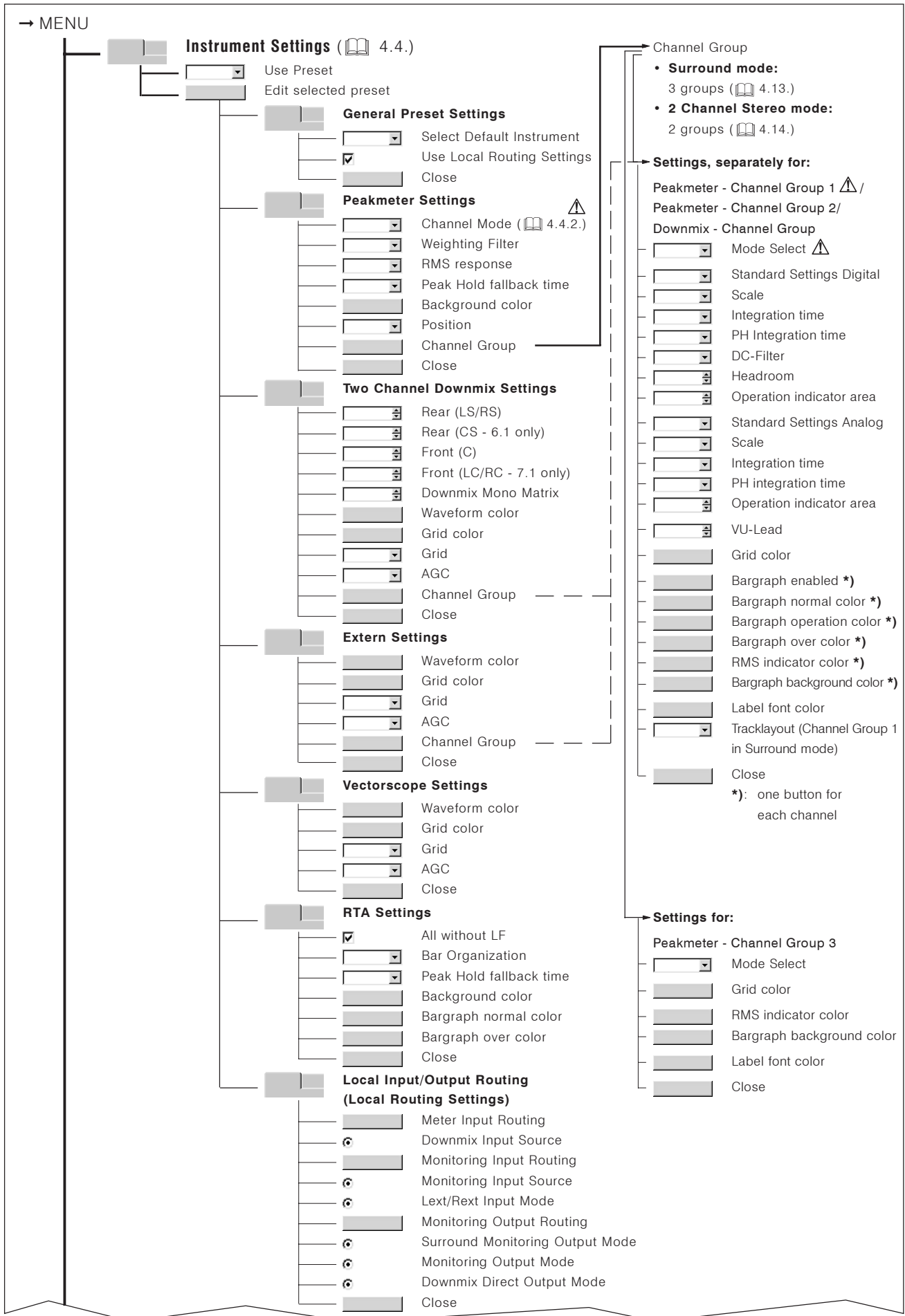

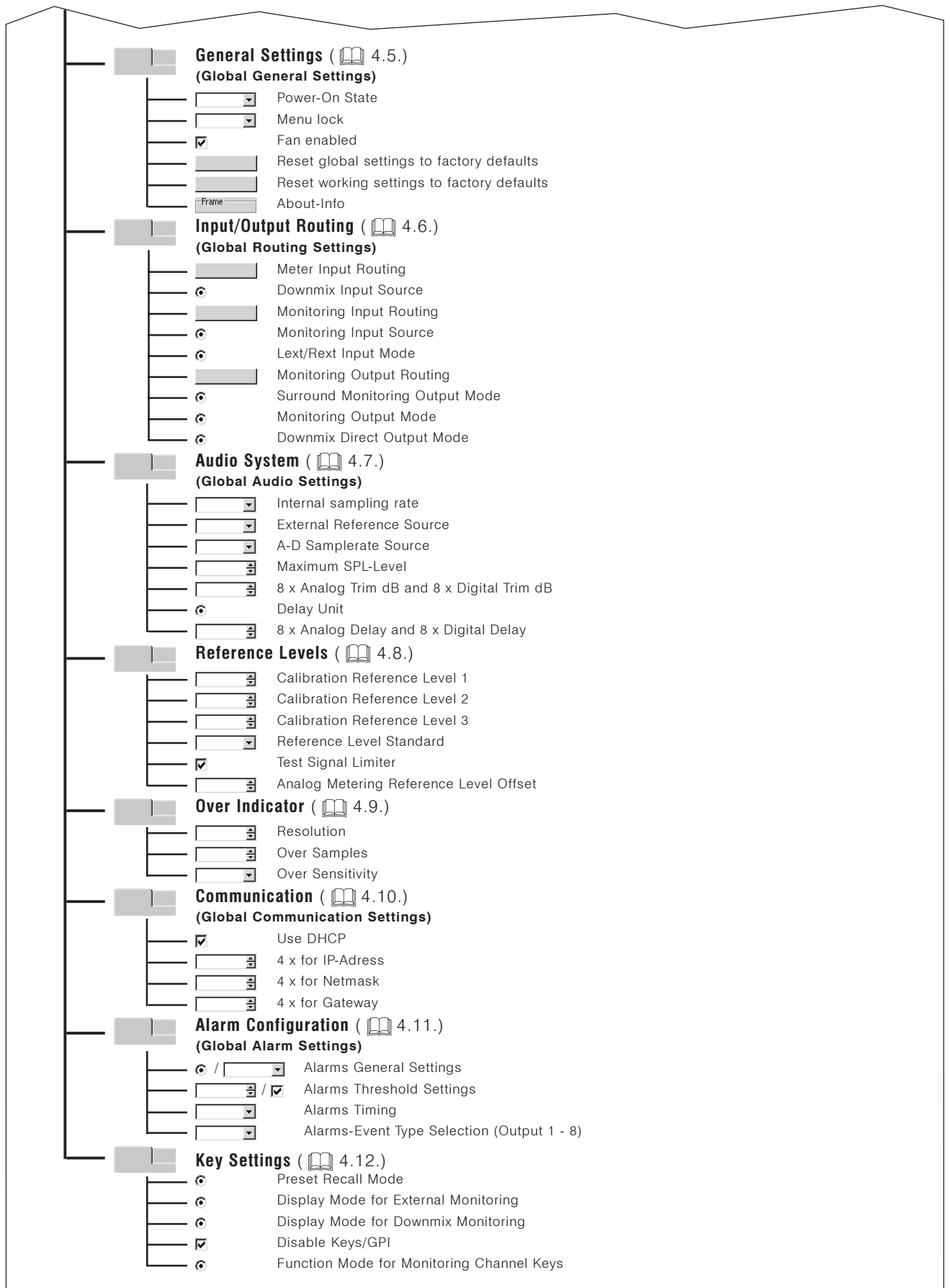

→ MENU

## 4.4 The Instrument Settings Menu



Start page  
(→ Instrument Settings)

This menu tab provides functions for selecting a preset (Use Preset, the currently selected preset is displayed) and for editing the selected preset. There are seven non-editable factory presets (F 15 to F 21) and fourteen editable user presets (U 1 to U 14). See Chapter 2.4 for details.

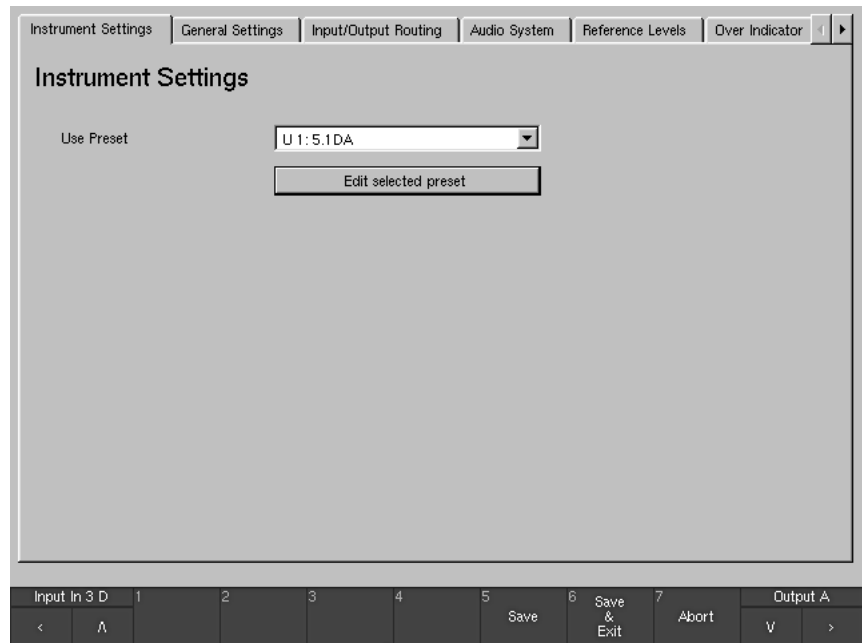

Fig. 4-3: The Instrument Settings menu tab

→ Edit selected preset

See Chapters 4.4.1 to 4.4.7  
and 4.13



The Edit selected preset button opens the Instrument Settings of the selected preset with the menu tabs for the instrument settings (see Fig. 4-4 in Chapter 4.4.1, Chapters 4.4.1 to 4.4.7 and Chapter 4.13).

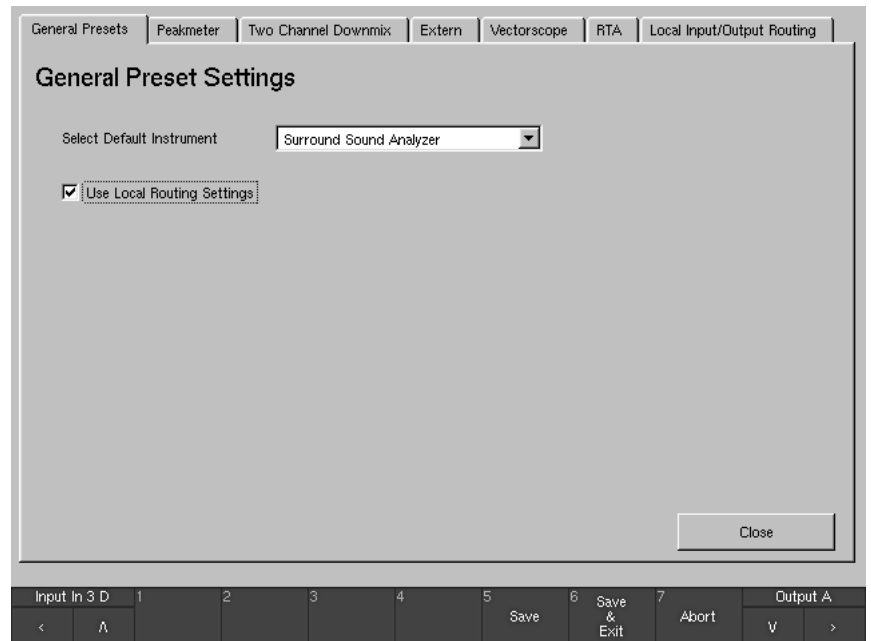



Fig. 4-4: The General Presets menu tab after selecting the Edit selected preset button

See Chapter 4.5



- **Select Default Instrument**   
This combo box is used to select the instrument that is displayed automatically with the selected preset in Window 3 of the screen display when the SurroundControl 30900(-24) is switched on.
- **Use Local Routing Settings**   
Differing from the Global Input/Output Routing settings (Global Routing Settings, see Chapter 4.6) the internal local routing settings can be used instead for the current preset. Selecting the check box activates the Local Input/Output menu tab for the configuration of the local routing settings (see Chapter 4.4.7).
- **Close**   
This button closes the page and prompts you to save the preset (see Chapter 4.1) to one of the user presets (U 1 to U 14). You can also enter an individual name for the preset with the Change name button (6 characters).

### 4.4.2 Peakmeter

(Peakmeter Settings, see Figs. 4-5 and 4-6)

- **Surround mode:**

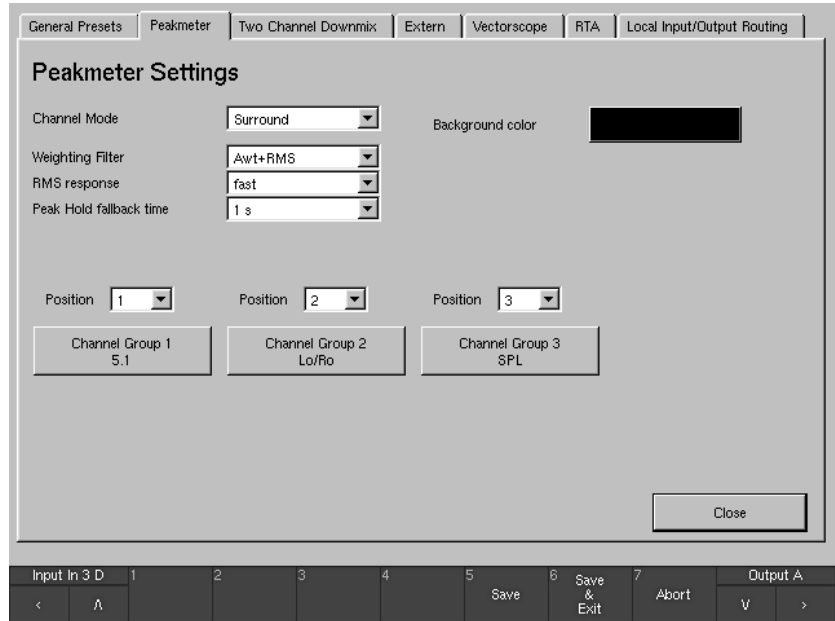

Fig. 4-5: The Peakmeter menu tab in Surround mode

- **2 Channel Stereo mode:**

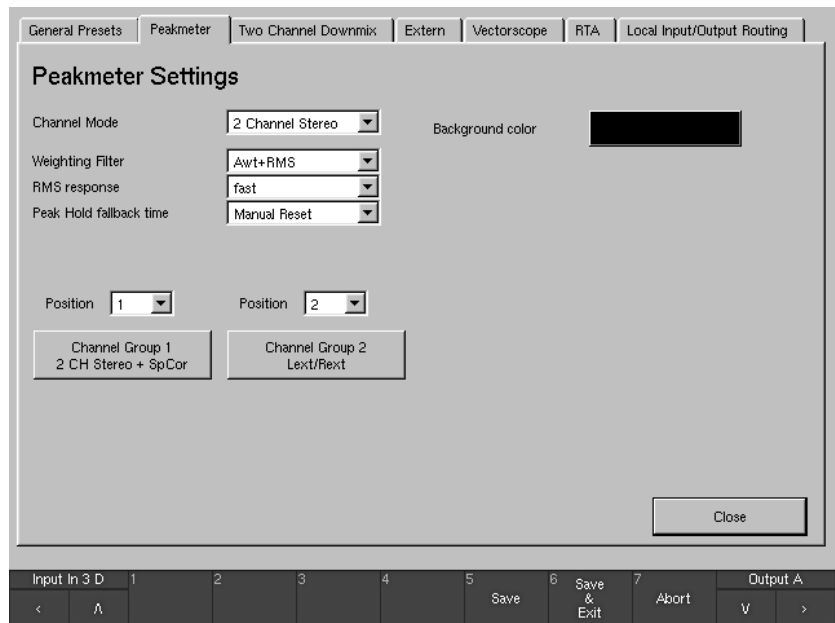



Fig. 4-6: The Peakmeter menu tab in 2 Channel Stereo mode



See Fig. 4-5 and Chapter 4.13   
 See Fig. 4-6 and Chapter 4.14 

- **Channel Mode** 

With this combo box Surround Mode or 2 Channel Stereo mode can be selected. Depending on the mode different numbers of Channel Groups are available:

  - Surround mode: 3 groups (see Fig. 4-5 and Chapter 4.13)
  - 2 Channel Stereo mode: 2 groups (see Fig. 4-6 and Chapter 4.14)

See Chapter 3.4.2 

- **Weighting Filter** 

This combo box is for selecting the weighting filter for the volume level display. Settings: Linear+RMS, Awt+RMS, Cwt+RMS.
- **RMS response** 

This combo box is for setting the response time of the RMS detector for the volume level display. Settings: fast, slow.
- **Peak Hold fallback time** 

This combo box is for setting the display duration for the peak hold display. Settings: 1s, 2s, 4s and manual. When manual is selected you can reset the peak hold display with the Reset function in the PPM instrument (see Chapter 3.4.2).

- **Background color** 

This button displays the color selector so that you can change the color of the background of the screen display.

- **Position** 

With these combo boxes the peakmeter channel groups can be activated and arranged (Off: deactivated, 1: position 1, the channel group is set to the left, 2: position 2, 3: position 3 and 4: position 4, the channel group is set to the right).

- **Channel Group 1, Channel Group 2, Channel Group 3** 

These buttons open the menu pages with the peakmeter settings for the corresponding channel groups (see Figs. 4-30 to 4-34).

Selecting the surround format:   
 See Chapter 4.13 (also 1.6.1)



- **Surround mode** (up to three groups):  
**The surround format for the entire SurroundControl 30900(-24) instrument is selected on the menu page for Channel Group 1 with Mode Select.** See Chapter 4.13 for full details on the Channel Group page in Surround mode.

Selecting the surround format:   
 See Chapter 4.14 (also 1.6.1)



- **2 Channel Stereo mode** (up to two groups):  
**This format for the entire SurroundControl 30900(-24) instrument is displayed on the menu page for Channel Group 1 with Mode Select.** See Chapter 4.14 for full details on the Channel Group page in 2 Channel Stereo mode.

- **Close** 

This button closes the page and prompts you to save the preset (see Chapter 4.1) to one of the user presets (U 1 to U 14). You can also enter an individual name for the preset with the Change name button (6 characters).

### 4.4.3 Two Channel Downmix

(Two Channel Downmix Settings, see Fig. 4-7)

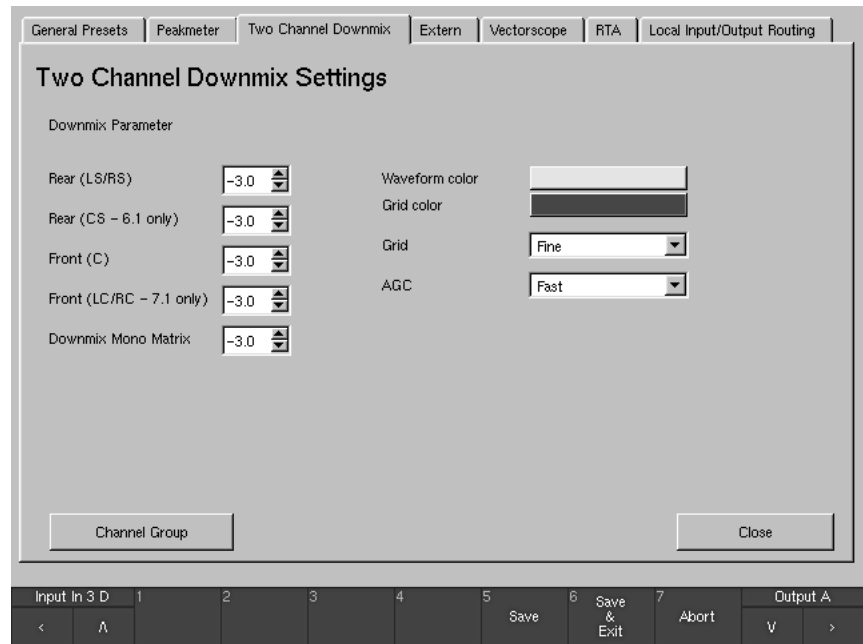

Fig. 4-7: The Two Channel Downmix menu tab

- **Rear Gain, Center Gain, Mono Gain, Rear Center Gain, L/R-Center Gain**

With these list boxes the mixing factors for the downmix matrix can be adjusted (values in dB, adjustment in 0.5 dB steps).

- **Waveform color** 

This button displays the color selector so that you can select the display color to be used for the signal in the vectorscope display.

- **Grid Color** 

This button displays the color selector so that you can select the display color to be used for the coordinate grid in the vectorscope display.

- **Grid**

This combo box is for changing the setting of the coordinate grid in the vectorscope display. Settings: Dots (fine) or lines (normal).

- **AGC**

This combo box is for adjusting the vectorscope's AGC (Automatic Gain Control) response time. Settings: fast or slow.

Selecting the downmix format:   
See Chapter 4.13 (also 1.6.1)



- **Channel Group** 

This button opens a separate menu page for the downmix channel group with the settings for the downmix peakmeter (see Fig. 4-35).  
See Chapter 4.13 for a detailed description of the Channel Group page.

- **Close** 

This button closes the page and prompts you to save the preset (see Chapter 4.1) to one of the user presets (U 1 to U 14). You can also enter an individual name for the preset with the Change name button (6 characters).

### 4.4.4 Extern

(Extern Settings, see Fig. 4-8)

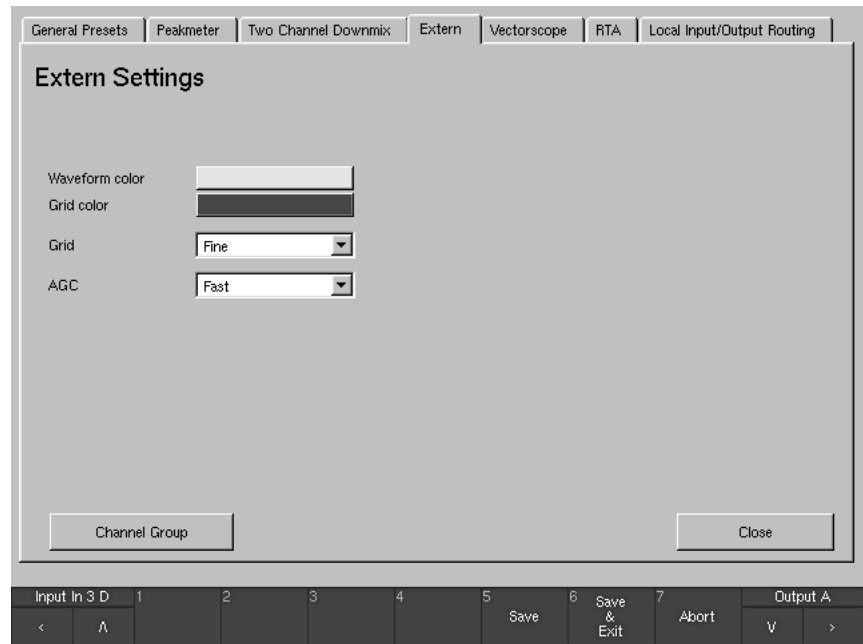







Fig. 4-8: The Extern Settings menu tab

- **Waveform color** 

This button displays the color selector so that you can select the display color to be used for the signal in the vectorscope display.
- **Grid Color** 

This button displays the color selector so that you can select the display color to be used for the coordinate grid in the vectorscope display.
- **Grid** 

This combo box is for changing the setting of the coordinate grid in the vectorscope display. Settings: Dots (fine) or lines (normal).
- **AGC** 

This combo box is for adjusting the vectorscope's AGC (Automatic Gain Control) response time. Settings: fast or slow.
- **Channel Group** 

This button opens a separate menu page for the Extern downmix channel group with the settings for the Extern downmix peakmeter (see Fig. 4-35). See Chapter 4.13 for a detailed description of the Channel Group page.
- **Close** 

This button closes the page and prompts you to save the preset (see Chapter 4.1) to one of the user presets (U 1 to U 14). You can also enter an individual name for the preset with the Change name button (6 characters).

See Chapter 4.13 (also 1.6.1) 

### 4.4.5 Vectorscope

(Vectorscope Settings, see Fig. 4-9)

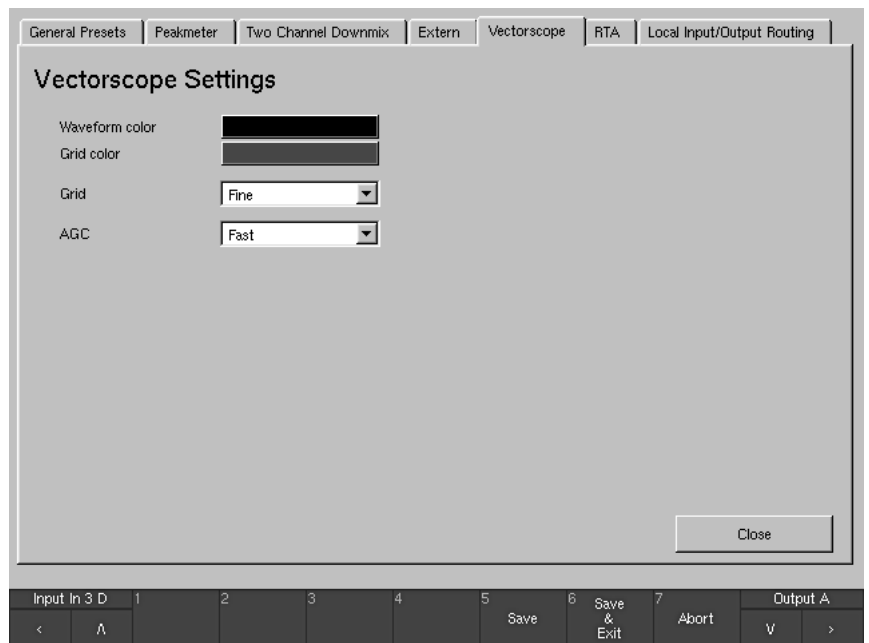







Fig. 4-9: The Vectorscope menu tab

- **Waveform color**   
 This button displays the color selector so that you can select the display color to be used for the signal in the vectorscope display.
- **Grid Color**   
 This button displays the color selector so that you can select the display color to be used for the coordinate grid in the vectorscope display.
- **Grid**   
 This combo box is for changing the setting of the coordinate grid in the vectorscope display. Settings: Dots (fine) or lines (normal).
- **AGC**   
 This combo box is for adjusting the vectorscope's AGC (Automatic Gain Control) response time. Settings: fast or slow.
- **Close**   
 This button closes the page and prompts you to save the preset (see Chapter 4.1) to one of the user presets (U 1 to U 14). You can also enter an individual name for the preset with the Change name button (6 characters).

### 4.4.6 RTA

(RTA Settings, see Fig. 4-10)

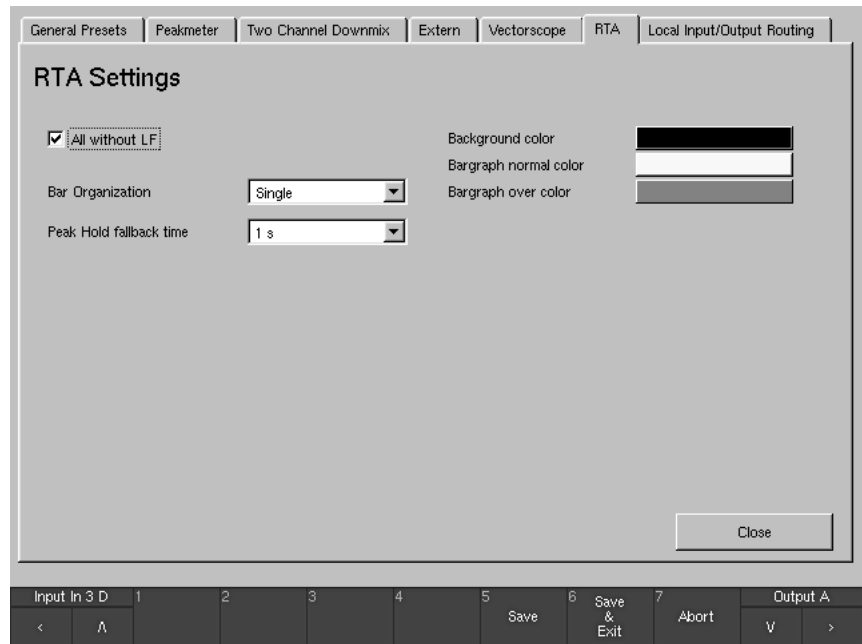

Fig. 4-10: The RTA menu tab

- **All without LF**

This check box determines the behaviour of function key/button 1 when the function Input Select (see Chapter 3.8.1) is selected in the instruments RTA 1/3 and RTA 1/6:

- If the box is not checked button/key 1 is labelled All. Then all channels including the LF channel are used for the Real-Time Analyzer display.
- If the box is checked the button/key is labelled All w/o LF. Then all channels except the LF channel are used for the Real-Time Analyzer display.

- **Bar Organization**

This combo box is for changing the way the bargraphs are arranged in the vectorscope display. You can choose between single bars (Single), groups of three (Group Terz) and blocks of three (Block Terz).

- **Peak Hold fallback time**



This combo box is for setting the display duration for the peak hold display. Settings: 1s, 2s, 4s and manual. When manual is selected you can reset the peak hold display with the PHold Reset function in the RTA 1/3 or RTA 1/6 instrument (see Chapter 3.8.12).

See Chapter 3.8.12



- **Background color**

This button displays the color selector so that you can change the color of the background of the bargraph display in the RTA instrument.

- **Bargraph normal color**   
This button displays the color selector so that you can choose the display color for the normal range of the bargraphs in the RTA instrument.
- **Bargraph over color**   
This button displays the color selector so that you can choose the display color for the overload range of the bargraphs in the RTA instrument.
- **Close**   
This button closes the page and prompts you to save the preset (see Chapter 4.1) to one of the user presets (U 1 to U 14). You can also enter an individual name for the preset with the Change name button (6 characters).

## 4.4.7 Local Input/Output Routing

(Local Routing Settings, see Fig. 4-11)

Format settings see Chapters 4.4.2, 4.13, 4.14 and 4.4.1 (also 1.6.1)



This menu page contains the options for setting the various **local** routing settings for all inputs and outputs for the **selected format**. This menu tab is only available when the Use Local Routing Settings check box is **activated** in the General Presets menu tab (see Chapter 4.4.1). The SurroundControl 30900(-24) then uses the settings configured here to allocate the physical inputs and outputs to the internal logical channels L, R and so on.

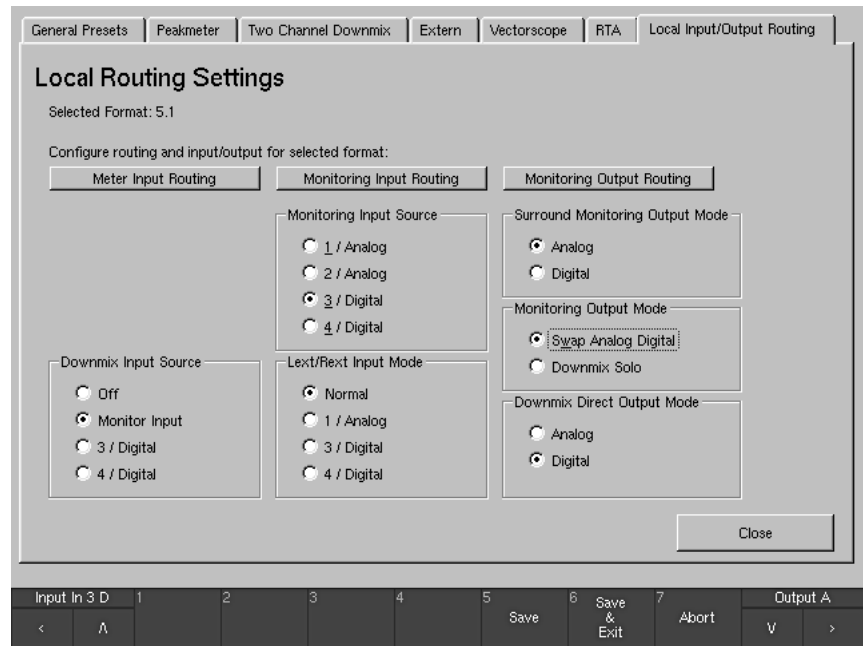

Fig. 4-11: The Local Input/Output Routing menu tab

→ Meter Input Routing (see Fig. 4-11)

See also Chapter 2.3.8



### • Meter Input Routing (see Fig. 4-12)

This button opens a new menu page with the routing matrix in which you can assign the internal logical channels L, R and so on to the physical inputs of the Meter In analog connection (see Chapter 2.3.8 and Fig. 4-12 on the following page). Available are in:

- 5.1 format: L, R, C, LF, LS, RS, L<sub>ext</sub>, R<sub>ext</sub>
- 6.1 format: L, R, C, LS, RS, CS, LF
- 7.1 format: L, R, LC, C, RC, LS, RS, LF

In 2 Channel Stereo mode (selected as Channel Mode at the Peakmeter Settings menu tab) an individual name (4 characters) can be entered to the internal logical channels. Therefore click the channel name with an optional computer mouse.



→ Meter Input Routing  
(see Fig. 4-11)

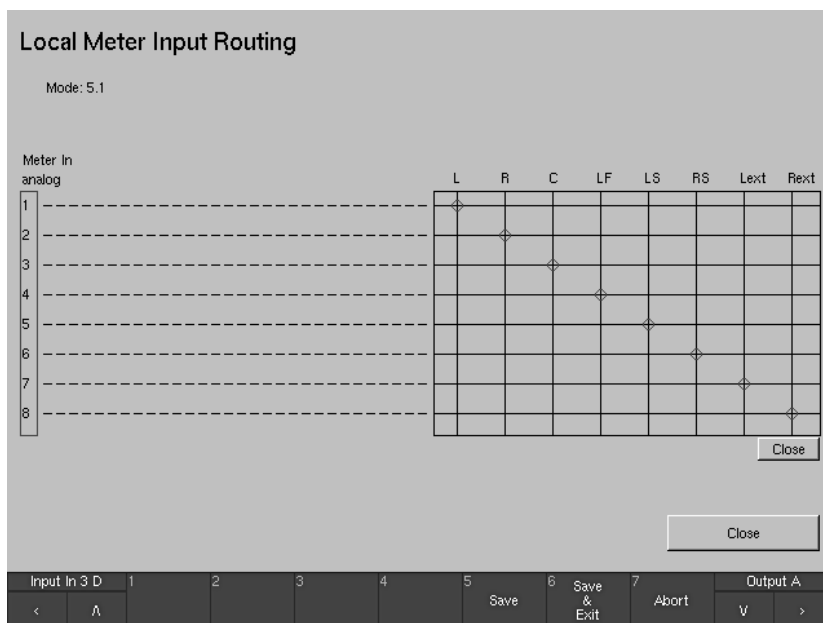

Fig. 4-12: Channel allocation matrix for the Meter Input Routing  
(Example: 5.1 format)

See also Chapters 4.2,  
2.3.9 to 2.3.12 and 1.6.7



• **Downmix Input Source**

The first option button deactivates the internal downmix matrix for outputting a stereo-compatible 2-channel downmix signal. With the three option buttons Monitor Input, 3/Digital and 4/Digital the input source of the signal to be used for generating the two-channel downmix can be selected. This input is independent of the input source selection of the Monitoring Controller (see Monitoring Input Routing).

→ Monitoring Input Routing  
(see Fig. 4-11)

• **Monitoring Input Routing** (see Fig. 4-13)

This button opens a new menu page with the routing matrix in which you can assign the physical inputs of the connections Monitoring In 1 analog, Monitoring In 2 analog, Monitoring In 3 digital and Monitoring In 4 digital (see Chapters 2.3.9 to 2.3.12 and Fig. 4-13 on the next page) in each case to the internal logical channels L, R and so on.

Available are in:

- 5.1 format: L, R, C, LF, LS, RS, L<sub>ext</sub>, R<sub>ext</sub>
- 6.1 format: L, R, C, LS, RS, CS, LF
- 7.1 format: L, R, LC, C, RC, LS, RS, LF

In 2 Channel Stereo mode (selected as Channel Mode at the Peakmeter Settings menu tab) an individual name (4 characters) can be entered to the internal logical channels. Therefore click the channel name with an optional computer mouse.

→ Monitoring Input Routing  
(see Fig. 4-11)

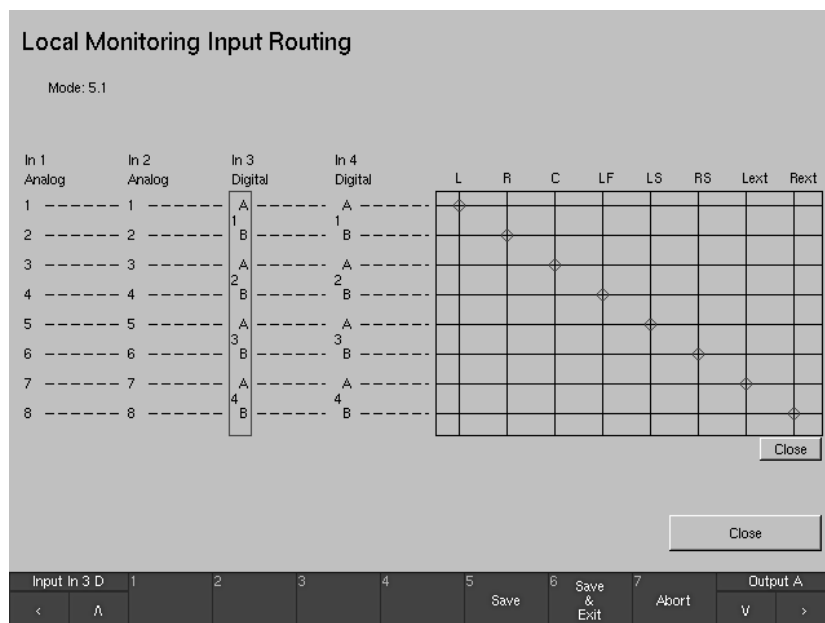

Fig. 4-13: Channel allocation matrix for the Monitoring Input Routing  
(Example: 5.1 format)

See Chapters 2.3.9 to 2.3.12



• **Monitoring Input Source**

These four option buttons select the input source for the monitoring controller (see Chapters 2.3.9 to 2.3.12). The current selection is also displayed in the Toolbar in the screen display. In normal mode the input source can also be selected with the Input key on the Remote Control 30050 unit (see Chapter 3.2 and Fig. 3-29). You can also select the input source directly by clicking on the button in the Toolbar with the optional mouse if one is connected.

(See also Chapter 3.2 and Fig. 3-29)



• **Lext/Rext Input Mode**

These four option buttons select the input source for the external signals  $L_{ext}$  and  $R_{ext}$ .

With the option button Normal activated the incoming signals  $L_{ext}$  and  $R_{ext}$  are linked to the selected monitoring input (see Monitoring Input Source). With the option buttons 1/Analog, 3/Digital and 4/Digital the incoming signals  $L_{ext}$  and  $R_{ext}$  may be forced to use via these inputs irrespective of the selected monitoring input (see Monitoring Input Source). Because of technical reasons the 2/Analog input is not selectable.

See Chapters 2.3.9, 2.3.11 and 2.3.12



See Chapter 4.12.2 and Fig. 4-30



See Chapter 3.15.7 and Fig. 3-29



If the Downmix meter (see 4.12.2 and Fig. 4-30) is activated simultaneously with the 2-Ch-Ex-to-Front function (EX key on the Remote Control 30050, see Chapter 3.15.7 and Fig. 3-29) the scales of the peakmeter are switched with respect to the input domain in use.

→ Monitoring Output Routing  
(see Fig. 4-11)

• **Monitoring Output Routing** (see Fig. 4-14)

This button opens a new menu page with the routing matrix in which the internal logical channels L, R and so on can be assigned to the physical outputs of the Monitoring analog Out (see Chapter 2.3.13) and Monitoring digital Out (see Chapter 2.3.14) connections (see Fig. 4-14). Available are in:

- 5.1 format: L, R, C, LF, LS, RS, L<sub>ext</sub>, R<sub>ext</sub>, VL<sub>0</sub>, VR<sub>0</sub>, DL<sub>0</sub>, DR<sub>0</sub>, DM<sub>0</sub>
- 6.1 format: L, R, C, LS, RS, CS, LF, VL<sub>0</sub>, VR<sub>0</sub>, DL<sub>0</sub>, DR<sub>0</sub>, DM<sub>0</sub>
- 7.1 format: L, R, LC, C, RC, LS, RS, LF, VL<sub>0</sub>, VR<sub>0</sub>, DL<sub>0</sub>, DR<sub>0</sub>, DM<sub>0</sub>

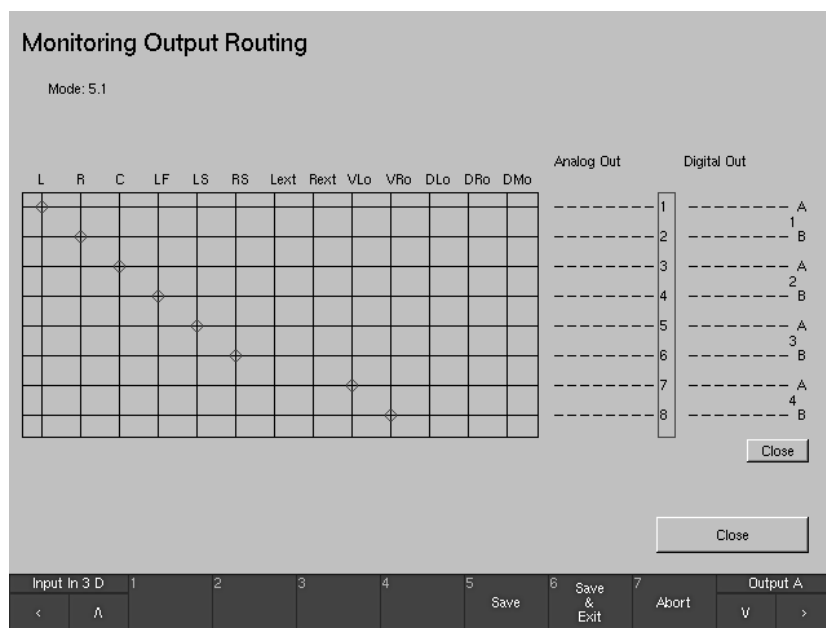

Fig. 4-14: Channel allocation matrix for the Monitoring Output Routing (Example: 5.1 format)

(See also Chapter 3.2 and Fig. 3-29)



• **Surround Monitoring Output Source**

These two option buttons select the monitoring output for normal mode operation. The current selection is also displayed in the Toolbar in the screen display. In normal mode the output source can also be selected with the Output key on the Remote Control 30050 unit (see Chapter 3.2 and Fig. 3-29). You can also select the output source directly by clicking on the button in the Toolbar with the optional mouse if one is connected.

(See also Chapter 3.2 3.15.14 and Fig. 3-29)



• **Monitoring Output Mode**

These two option buttons define the function of the Output key on the Remote Control 30050 unit (see Chapter 3.15.14 and Fig. 3-29):

- When you select Swap Analog Digital the Output key swaps the surround monitoring signal between the analog (display in the Toolbar: Output A) and the digital output (display in the Toolbar: Output D).
- When you select Downmix Solo the Output key switches the Downmix Volume Out signal (see Chapter 4.2) to the channels set in Output Routing and mutes all other channels (the display in the Toolbar changes between Output A/Output D and Downmix A/Downmix D).

- **Downmix Direct Output Mode** 

With these two option buttons the output domain (analog or digital) resp. the output connector for the downmix direct out signals  $DL_0$ ,  $DR_0$  and  $DM_0$  can be selected. This is then used irrespective of the selection made with the Output key of the Remote Control 30050.

- **Close** 

This button closes the page and prompts you to save the preset (see Chapter 4.1) to one of the user presets (U 1 to U 14). You can also enter an individual name for the preset with the Change name button (6 characters).

### Changing the routing in the matrixes

- Press the  $\blacktriangledown$  or  $\blacktriangle$  cursor key until the input or output path for which you want to change the routing has the focus (dashed frame).
- Confirm with the SEL(ECT) key. A red frame is displayed around the selected input or output path.
- Now press the  $\blacktriangledown$  or  $\blacktriangle$  cursor key until the matrix field has the focus (dashed frame).
- Confirm with the SEL(ECT) key. A blue circle is displayed around the topmost red node (red circle), indicating that it has the focus.
- You can now move the blue circle to one the intersections in the matrix with the cursor keys.
- Pressing SEL(ECT) key defines the new node at the selected intersection, thus also defining the new assignment of an input channel to an internal logical channel or an internal logical channel to an output channel.
  - In the Input Routing this deletes an existing node (red circle) on the vertical line and replaces it with a new one.  
You can route a single input signal to multiple internal channels.
  - In the Output Routing this deletes an existing node (red circle) on the horizontal line and replaces it with a new one.  
You can route a single internal signal to multiple output channels.
- If you move the cursor (blue circle) over an existing node (red circle) and press the SEL(ECT) key the node is deleted, cancelling the assignment and the signal routing.
- With the cursor keys  $\blacktriangledown$  or  $\blacktriangle$  move to the small Close button until it has the focus (dashed frame), the blue circle disappears. Pressing the SEL(ECT) button selects the matrix settings.
- With the tall Close button you can return to the Routing Settings menu tab.
- Now you can use the  $\blacktriangledown$  and  $\blacktriangle$  cursor keys to select the next menu option.
- Please note that the screenshots in this chapter and Chapter 2.4.8 show default configurations.

See Figs. 4-11 to 4-14  
and Chapter 2.4.8



## 4.5 The General Settings Menu

(Global General Settings, see Fig. 4-15)

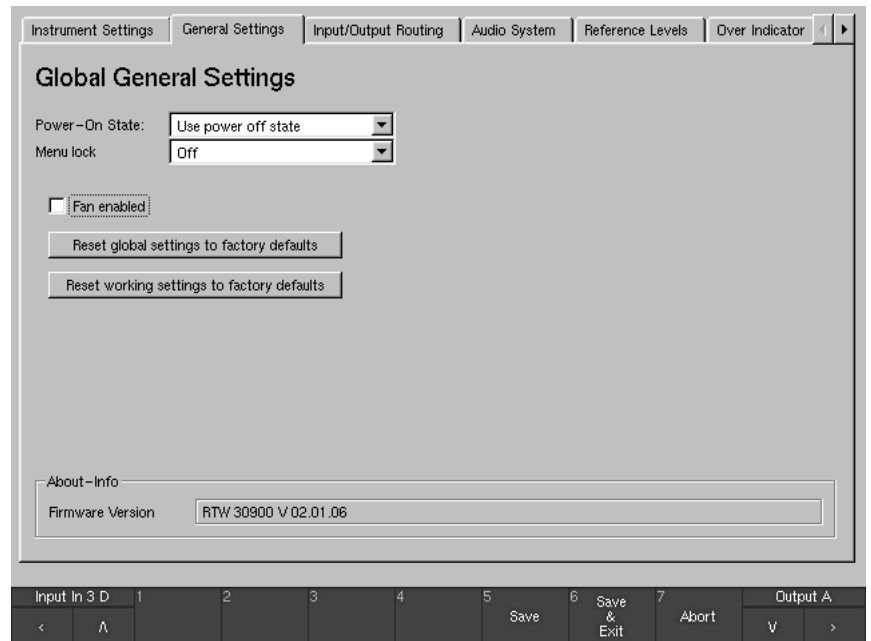

Fig. 4-15: The General Settings menu tab

- **Power-On State**

This combo box selects the preset that is loaded and activated when the SurroundControl 30900(-24) is switched on (Use Preset ...). You can select any of the fourteen user presets (U 1 to U 14) or the seven factory presets (F 15 to F 21). Selecting Use power-off state loads the last preset used when the unit was switched off.

- **Menu lock**

This combo box allows you to choose whether the menus are freely accessible (Off) or only accessible when the user enters one of the eight 4-digit numeric codes (PINs). If you activate the menu lock function by selecting a PIN a prompt asking the user to enter the PIN code will be displayed when the MENU button/key is activated in normal mode. The buttons in the Toolbar are then labelled with numbers to allow entry of the PIN code. The digits 1 to 6 are displayed on the first level and the digits 7 to 9, digit 0 and a backspace key (DEL) are displayed on the second level of the menu, which can be displayed by selecting the button/key >. Pressing the < key takes you back to the first level. On both levels the seventh button/key in the Toolbar is an Abort function, with which the procedure can be cancelled.

- **Fan enabled**

With this check box an internal fan can be activated or deactivated. At delivery the check box is activated and the fan is switched on.

- **Reset global settings to factory defaults**

With this button all Global Settings (all menu tabs except the Instrument Settings menu tab) can be set back to the factory default settings. A safety request has to be confirmed.

- **Reset working settings to factory defaults**

With this button all Instrument Settings (this menu tab appears when the menu button/key was pressed) can be set back to the factory default settings. A safety request has to be confirmed.

- **About - Info**

This frame displays information on the firmware version of your RTW unit.

## 4.6 The Input/Output Routing Menu

(Global Routing Settings, see Fig. 4-16)

See Chapters 4.4.2, 4.13, 4.14 and 4.4.1 (also 1.6.1)



This menu page contains the options for setting the various **global** routing settings for all inputs and outputs for the **selected format**. When the Use Local Routing Settings check box is **deactivated** in the General Presets menu tab (see Chapter 4.4.1) the SurroundControl 30900(-24) uses the global settings configured here to allocate the physical inputs and outputs to the internal logical channels L, R and so on.

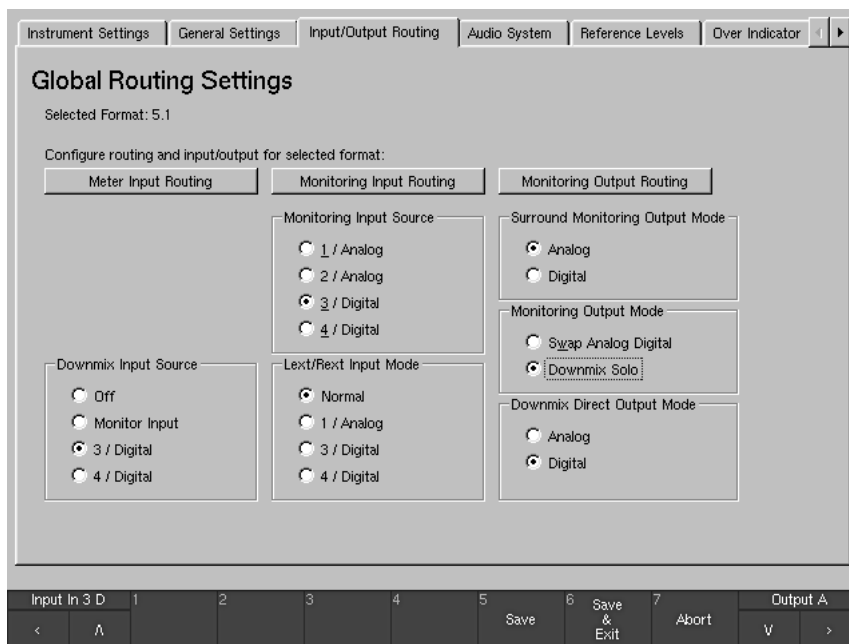

Fig. 4-16: The Input/Output Routing menu tab

→ Meter Input Routing (see Fig. 4-16)

See also Chapter 2.3.8



### • **Meter Input Routing** (see Fig. 4-17)

This button opens a new menu page with the routing matrix in which you can assign the internal logical channels L, R and so on to the physical inputs of the Meter In analog connection (see Chapter 2.3.8 and Fig. 4-17 on the following page). Available are in:

- 5.1 format: L, R, C, LF, LS, RS, L<sub>ext</sub>, R<sub>ext</sub>
- 6.1 format: L, R, C, LS, RS, CS, LF
- 7.1 format: L, R, LC, C, RC, LS, RS, LF

In 2 Channel Stereo mode (selected as Channel Mode at the Peakmeter Settings menu tab) an individual name (4 characters) can be entered to the internal logical channels. Therefor click the channel name with an optional computer mouse.

→ Meter Input Routing  
(see Fig. 4-16)

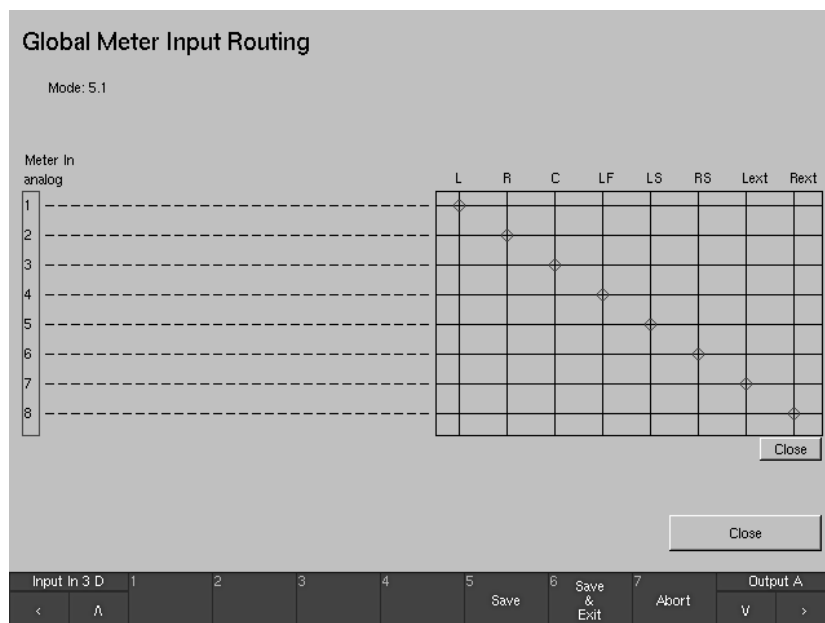

Fig. 4-17: Channel allocation matrix for the Meter Input Routing  
(Example: 5.1 format)

See also Chapters 4.2,  
2.3.9 to 2.3.12 and 1.6.7



• **Downmix Input Source**

The first option button the internal downmix matrix for outputting a stereo-compatible 2-channel downmix signal can be deactivated.

With the three option buttons Monitor Input, 3/Digital and 4/Digital the input source of the signal to be used for generating the two-channel downmix can be selected. This input is independent of the input source selection of the Monitoring Controller (see Monitoring Input Routing).

→ Monitoring Input Routing  
(see Fig. 4-16)

• **Monitoring Input Routing** (see Fig. 4-18)

This button opens a new menu page with the routing matrix in which you can assign the physical inputs of the connections Monitoring In 1 analog, Monitoring In 2 analog, Monitoring In 3 digital and Monitoring In 4 digital (see Chapters 2.3.9 to 2.3.12 and Fig. 4-18 on the next page) in each case to the internal logical channels L, R and so on.

Available are in:

- 5.1 format: L, R, C, LF, LS, RS, L<sub>ext</sub>, R<sub>ext</sub>
- 6.1 format: L, R, C, LS, RS, CS, LF
- 7.1 format: L, R, LC, C, RC, LS, RS, LF

In 2 Channel Stereo mode (selected as Channel Mode at the Peakmeter Settings menu tab) an individual name (4 characters) can be entered to the internal logical channels. Therefore click the channel name with an optional computer mouse.



→ Monitoring Input Routing  
(see Fig. 4-16)

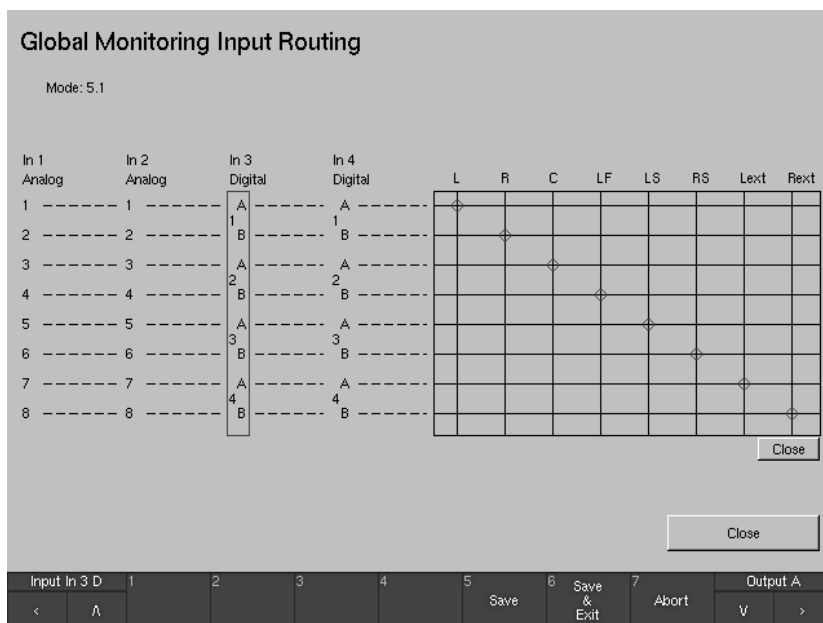

Fig. 4-18: Channel allocation matrix for the Monitoring Input Routing  
(Example: 5.1 format)

See Chapters 2.3.9 to 2.3.12



• **Monitoring Input Source**

These four options select the input source for the monitoring controller. The current selection is also displayed in the Toolbar in the screen display. In normal mode the input source can also be selected with the Input key on the Remote Control 30050 unit (see Chapter 3.2 and Fig. 3-27). You can also select the input source directly by clicking on the button in the Toolbar with the optional mouse if one is connected.

(See also Chapter 3.2 and Fig. 3-29)



• **Lext/Rext Input Mode**

These four option buttons select the input source for the external signals  $L_{ext}$  and  $R_{ext}$ .

With the option button Normal activated the incoming signals  $L_{ext}$  and  $R_{ext}$  are linked to the selected monitoring input (see Monitoring Input Source). With the option buttons 1/Analog, 3/Digital and 4/Digital the incoming signals  $L_{ext}$  and  $R_{ext}$  may be used via these inputs irrespective of the selected monitoring input (see Monitoring Input Source). Because of technical reasons the 2/Analog input is not selectable.

See Chapters 2.3.9, 2.3.11 and 2.3.12



If the Downmix meter (see 4.12.2 and Fig. 4-30) is activated simultaneously with the 2-Ch-Ex-to-Front function (EX key on the Remote Control 30050, see Chapter 3.15.7 and Fig. 3-29) the scales of the peakmeter are switched with respect to the input domain in use.

See Chapter 4.12.2 and Fig. 4-30



See Chapter 3.15.7 and Fig. 3-29



→ Monitoring Output Routing  
(see Fig. 4-16)

• **Monitoring Output Routing** (see Fig. 4-19)

This button opens a new menu page with the routing matrix in which the internal logical channels L, R and so on can be assigned to the physical outputs of the Monitoring analog Out (see Chapter 2.3.13) and Monitoring digital Out (see Chapter 2.3.14) connections (see Fig. 4-19). Available are in:

- 5.1 format: L, R, C, LF, LS, RS, L<sub>ext</sub>, R<sub>ext</sub>, VL<sub>0</sub>, VR<sub>0</sub>, DL<sub>0</sub>, DR<sub>0</sub>, DM<sub>0</sub>
- 6.1 format: L, R, C, LS, RS, CS, LF, VL<sub>0</sub>, VR<sub>0</sub>, DL<sub>0</sub>, DR<sub>0</sub>, DM<sub>0</sub>
- 7.1 format: L, R, LC, C, RC, LS, RS, LF, VL<sub>0</sub>, VR<sub>0</sub>, DL<sub>0</sub>, DR<sub>0</sub>, DM<sub>0</sub>

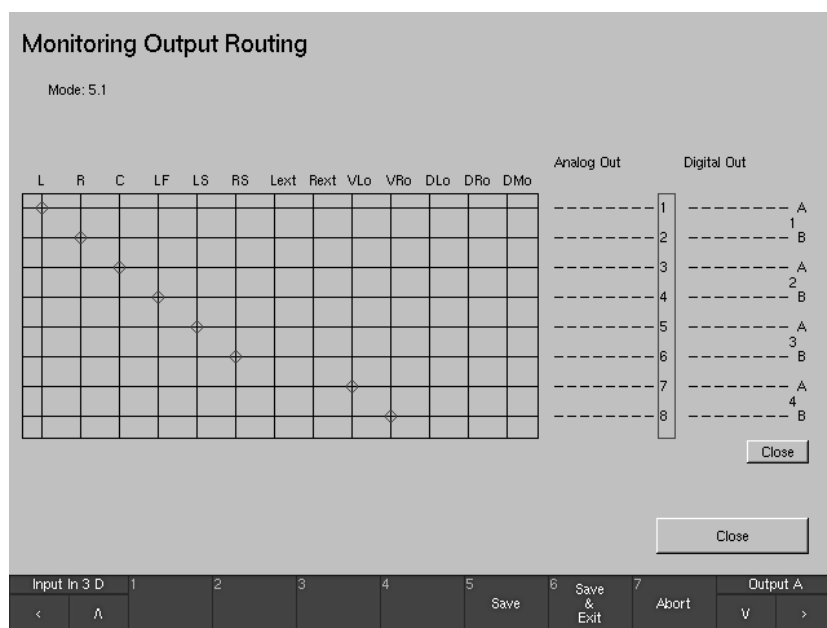

Fig. 4-19: Channel allocation matrix for the Monitoring Output Routing (Example: 5.1 format)

(See also Chapter 3.2 and Fig. 3-29)



• **Surround Monitoring Output Source**

These two option buttons select the monitoring output for normal mode operation. The current selection is also displayed in the Toolbar in the screen display. In normal mode the output source can also be selected with the Output key on the Remote Control 30050 unit (see Chapter 3.2 and Fig. 3-29). You can also select the output source directly by clicking on the button in the Toolbar with the optional mouse if one is connected.

(See also Chapter 3.2, 3.15.14 and Fig. 3-29)



• **Monitoring Output Mode**

These two options define the function of the Output key on the Remote Control 30050 unit (see Chapter 3.15.14 and Fig. 3-29):

- When you select Swap Analog Digital the Output key swaps the surround monitoring signal between the analog (display in the Toolbar: Output A) and the digital output (display in the Toolbar: Output D).
- When you select Downmix Solo the Output key switches the Downmix Volume Out signal (see Chapter 4.2) to the channels set in Output Routing and mutes all other channels (the display in the Toolbar changes between Output A/Output D and Downmix A/Downmix D).

- **Downmix Direct Output Mode** 

With these two option buttons the output domain (analog or digital) resp. the output connector for the downmix direct out signals  $DL_0$ ,  $DR_0$  and  $DM_0$  can be selected. This is then used irrespective of the selection made with the Output key of the Remote Control 30050.

- **Close** 

This button closes the page and prompts you to save the preset (see Chapter 4.1) to one of the user presets (U 1 to U 14). You can also enter an individual name for the preset with the Change name button (6 characters).

### Changing the routing in the matrixes

- Press the  $\blacktriangledown$  or  $\blacktriangle$  cursor key until the input or output path for which you want to change the routing has the focus (dashed frame).
- Confirm with the SEL(ECT) key. A red frame is displayed around the selected input or output path.
- Now press the  $\blacktriangledown$  or  $\blacktriangle$  cursor key until the matrix field has the focus (dashed frame).
- Confirm with the SEL(ECT) key. A blue circle is displayed around the topmost red node (red circle), indicating that it has the focus.
- You can now move the blue circle to one the intersections in the matrix with the cursor keys.
- Pressing SEL(ECT) key defines the new node at the selected intersection, thus also defining the new assignment of an input channel to an internal logical channel or an internal logical channel to an output channel.
  - In the Input Routing this deletes an existing node (red circle) on the vertical line and replaces it with a new one.  
You can route a single input signal to multiple internal channels.
  - In the Output Routing this deletes an existing node (red circle) on the horizontal line and replaces it with a new one.  
You can route a single internal signal to multiple output channels.
- If you move the cursor (blue circle) over an existing node (red circle) and press the SEL(ECT) key the node is deleted, cancelling the assignment and the signal routing.
- With the cursor keys  $\blacktriangledown$  or  $\blacktriangle$  move to the small Close button until it has the focus (dashed frame), the blue circle disappears. Pressing the SEL(ECT) button selects the matrix settings.
- With the tall Close button you can return to the Routing Settings menu tab.
- Now you can use the  $\blacktriangledown$  and  $\blacktriangle$  cursor keys to select the next menu option.
- Please note that the screenshots in this chapter and Chapter 2.4.8 show default configurations.

See Figs. 4-16 to 4-19  
and Chapter 2.4.8



## 4.7 The Audio System Menu

(Global Audio Settings, see Fig. 4-20)

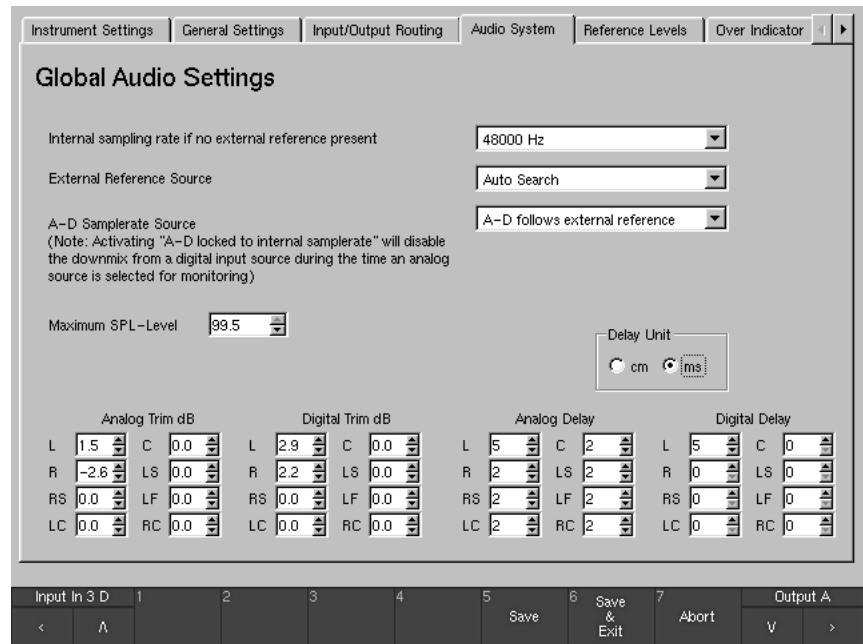

Fig. 4-20: The Audio System menu tab

- **Internal sampling rate if no digital signal present**

With this combo box the internal sampling rate (44100 Hz, 48000 Hz, 96000 Hz) can be set to be used for the analog inputs when no digital signal is available to be used as a reference sync signal. As soon as digital signals are input to the SurroundControl 30900(-24) or a valid external reference signal is available and is selected as the sync source with the External Reference Source combo box (see below) the internal A/D and D/A converter and the digital outputs will always use the sampling rate of the digital signal or reference sync signal.

- **External Reference Source**

This combo box is for setting the mode for the external reference sync signal:

- Auto Search: This setting automatically polls the digital inputs for a valid digital signal. As soon as a valid signal is found it is used as the reference sync signal. If this signal is no longer available the system polls the other inputs until it finds a valid signal, and the digital inputs are muted while this is being done.

See Chapter 2.3.15



- Use Ref Input:

Presets the system to the Ref Sync IN input (see Chapter 2.3.15), which can be used to input the reference sync signal.

**Important:**

No automatic search is performed when this setting is activated!

If there is no reference sync signal the digital input signals are no longer displayed and the analog input signals are only displayed with a very narrow bandwidth.



- Use Dig ... Input ...:

One of the eight available digital inputs can be selected so that its digital signal can be used as the reference sync signal.

**Important:**

No automatic search is performed when this setting is activated!

- **A-D Samplerate Source**

This function is only available when Auto Search is selected for External Reference Source:

- A-D follows external reference:

The SurroundControl 30900(-24) uses the external sample rate with analog signals.

- A-D locked to internal samplerate:

The SurroundControl 30900(-24) uses the selected internal sample rate (see Internal sampling rate if no digital signal present). Digital signals are synchronised to the adjacent digital sample rate.



**Important:**

Activating this function will disable the down-mix from a digital input source during the time an analog source is selected for monitoring.

See Chapter 3.15.11 and Fig. 3-29



- **Maximum SPL-Level**

This list box can be used to define an upper monitoring SPL level limit (see Fig. 3-29 and Chapter 3.15.11). The range is: 10 dB to 99,5 dB.

See Chapter 3.11.1 and Fig. 3-16



- **Analog Trim dB/Digital Trim dB**

These list boxes read the monitor level trim values of individual speaker channels selected as defined in the Cal instrument (see Chapter 3.11.1 and Fig. 3-16). A modification can also be performed here.

See Chapter 3.11.3



• **Delay Unit**

The delay setting can be made with the units cm or ms. This function corresponds to the Delay Unit function of the Cal instrument (see Chapter 3.11.3).

- ms: Allows you to set the desired delay individually for each channel
- cm: Deviation of the loudspeaker's position from the ITU ideal position in cm

• **Analog Delay/Digital Delay**

With these list boxes the delay values can be set separately for both analog or digital outputs (see the Cal instrument, the sub-function of the Monitoring instrument, in Chapters 3.11.2 and 3.11.3, also see 1.7).

See Chapters 3.11.2 and 3.11.3, also 1.7



With the selection **ms** as the unit (see Delay Unit above and Chapter 3.11.3) individual time delay values may be set for all speaker channels.

With the selection **cm** as the unit the left front speaker (L) is used as the reference point. Loudspeaker positioning according to the ITU standard is assumed as the basis. Deviations from this ideal circle can be set for all loudspeaker positions in the Cal instrument as positive (larger) and negative (smaller) distance values in cm, separately for analog and digital outputs:

- Entering positive values in the Cal instrument delays the selected channel and moves it back acoustically. The corresponding values are also displayed on the Audio System menu tab in the list boxes for the delay (see Fig. 4-21 and Chapter 3.11.3).

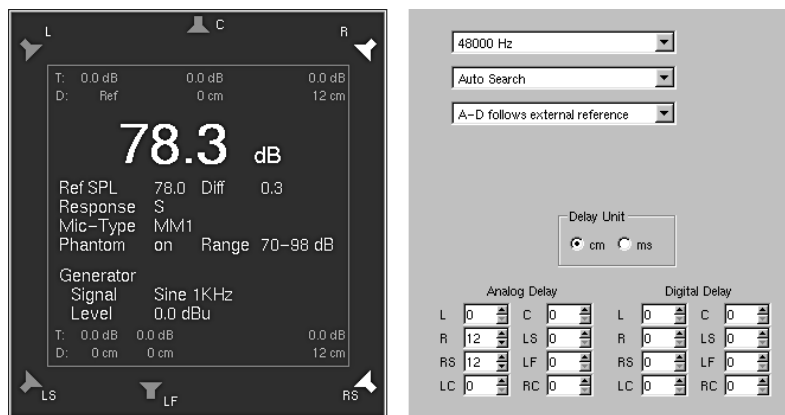

Fig. 4-21: Comparison of the entered positive delay values in the Cal instrument and the displayed values on the Audio System menu card



- Entering negative values in the Cal instrument (i. e. -12 cm) leaves the selected channel unchanged and applies the select delay value (i. e. 12 absolute) to all the other channels. All channels are delayed except the selected channel, thus moving the selected channel forward acoustically. This is reflected in the values displayed in the delay list boxes on the Audio System menu tab (see Fig. 4-22 and Chapter 3.11.3, i. e. selected channels: 0 cm, all the other: 12 cm)

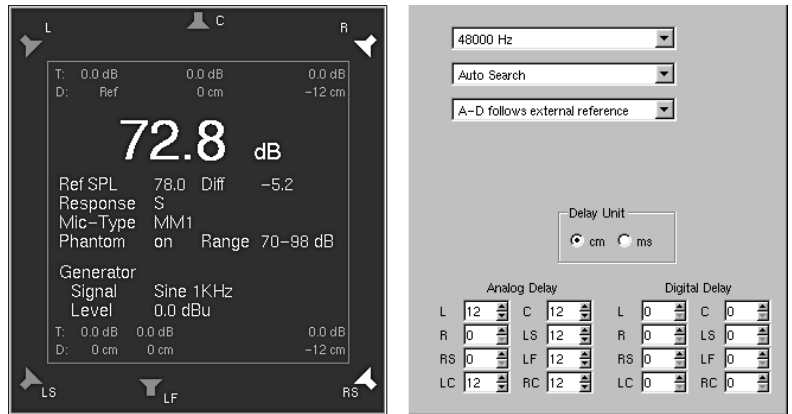

Fig. 4-22: Comparison of the entered negative delay values in the Cal instrument and the displayed values on the Audio System menu card

## 4.8 The Reference Levels Menu

(See Fig. 4-23)

See Chapter 3.12



The options in this menu tab preset the reference levels of the analog inputs and outputs and the calibration levels of the test signal generator (see Chapter 3.12).

The Analog Metering Reference Level Offset list box can be used to adjust the analog inputs to the local applications.

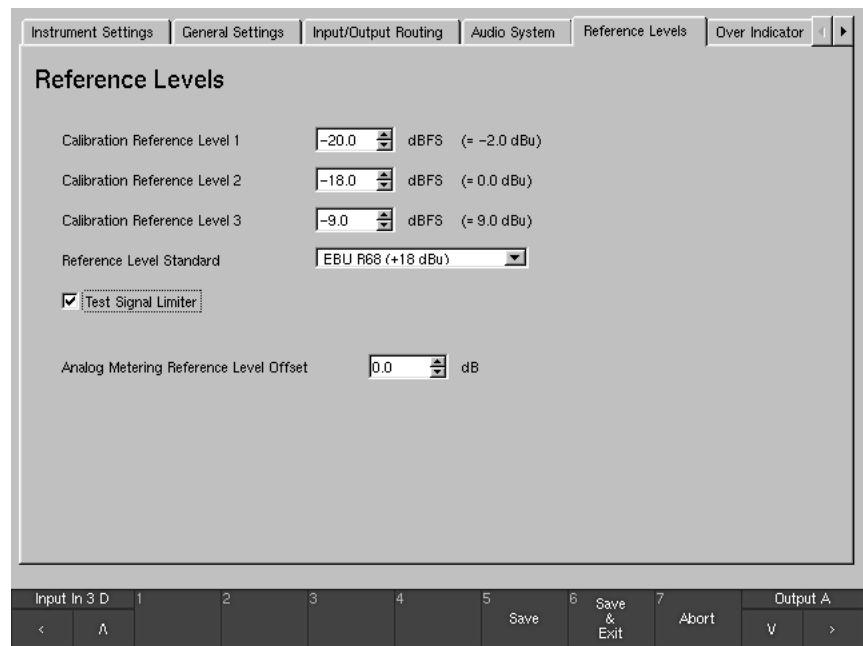

Fig. 4-23: The Reference Levels menu tab

• **Calibration Reference Level ...**

These list boxes are for the preset of the different output levels for the test signal generator. The factory defaults are -20 dB FS, -18 dB FS and -9 dB FS. You can adjust the values in 0.5 dB steps. The current settings are also converted to dBu and displayed to the right of the list boxes.

• **Reference Level Standard**

This combo box sets the analog output level that corresponds to the digital value 0 dB FS. For SurroundControl 30900 and 30900-24 you can select:

- EBU R68 (+18 dBu)
- ARD HFBL-K (+15 dBu)

**Only** for SurroundControl 30900-24!



With the SurroundControl 30900-24 you additionally can select:

- SMPTE/RP155 (+24 dBu)
- User (+18..+24 dBu)

When User is selected an additional list box is displayed for the individual selection of the maximum level in a range from +18 dBu to +24 dBu.





• **Test Signal Limiter**

The levels of the sine wave signals of the test signal generator (see Chapter 3.12.3) have an automatic limiter to protect the monitoring system:

- to -9 dB FS up to 1 kHz
- to -18 dB FS above 1 kHz

The Test Signal Limiter is always activated by default. You can deactivate it by deselecting this check box.

• **Analog Metering Reference Level Offset**

With this list box the reference level of the Metering display can be adapted to local conditions. Selections can be made in 0.1 dB steps in a range of  $\pm 8$  dB.

• Example:

The SurroundControl 30900(-24) is preset by factory to „0 dB“ display at +6 dBu input level for analog signals using the DIN scale.

Selecting +1 dB in Analog Metering Reference Level Offset list box delays the „0 dB“ mark of the Metering on the scale up with a value of 1 dB.

Viewed in an other way a signal damping of 1 dB is made. This means that an input signal level of +6 dBu is displayed not yet as „0 dB“ but as „-1 dB“.

Inversely the selection of -1 dB in Analog Metering Reference Level Offset list box delays the „0 dB“ mark on the scale down with a value of 1 dB. This means that a signal amplification of 1 dB is made.

## 4.9 The Over Indicator Menu

(See Fig. 4-24)

This menu tab contains options for setting the response of the digital Over indicator.

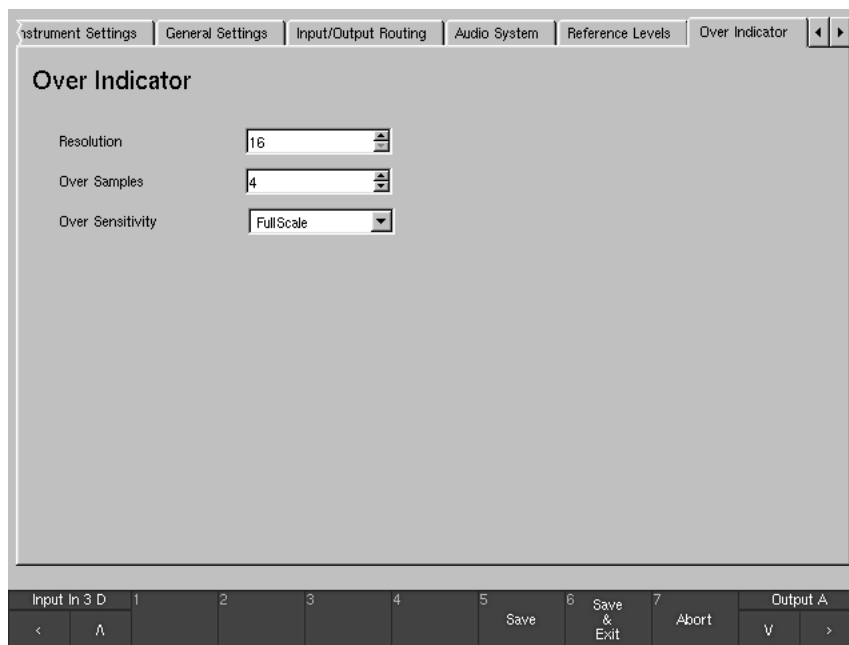

Fig. 4-24: The Over Indicator menu tab

See Fig. 1-5 in Chapter 1.6.1



- Resolution**

This list box allows you to switch the digital word length to be evaluated for the Over display between 16 and 24 bits.
- Over Samples**

This list box is for setting the number of directly successive samples that must meet the condition set with the Over Sensitivity option (see below) for an Over display to be triggered. You can adjust the number of Over Samples between 1 and 15.
- Over Sensitivity**

This combo box is for setting the response threshold for the Over display. Available conditions: Full Scale, Full Scale -1LSB, Full Scale -2 LSB, -0.1 dB, -0.5 dB, -1.0 dB, -2.0 dB and -3.0 dB.

## 4.10 The Communication Menu

(Global Communication Settings, see Fig. 4-25)

This menu tab is used to set an IP address for operation of the unit in a network. This address is essential for software upgrades or the import or export of user presets. See Chapter 5 for detailed informations.

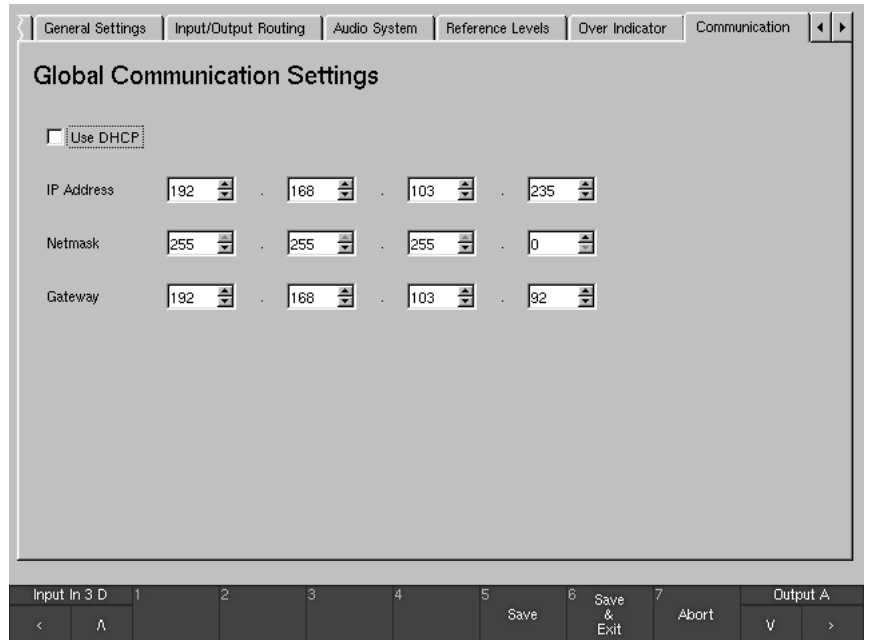

Fig. 4-25: The Communication menu tab

- **Use DHCP** (Dynamic Host Configuration Protocol) 

With this check box the automatic and dynamic allocation of an IP address can be activated when a suitable server is used.

**Please note:**  
The use of the SurroundControl 30900(-24) in **large** networks resp. **without any connection** to a network with the DHCP **activated** causes a **longer** start-up periode.
- **IP Address** 4 x 

The SurroundControl 30900(-24) can be accessed in a network via an IP address. You must set all four 3-digit blocks of the address in the four list boxes.
- **Netmask** 4 x 

With these four list boxes can be chosen up to what part of an IP address the network or the computer is specified.
- **Gateway** 4 x 

With these four list boxes the IP address of the computer used as bridge to other networks can be set.

## 4.11 The Alarm Configuration Menu

(Global Alarm Settings, see Fig. 4-26)

The options in this menu tab preset the display or output of alarm events for the modes.

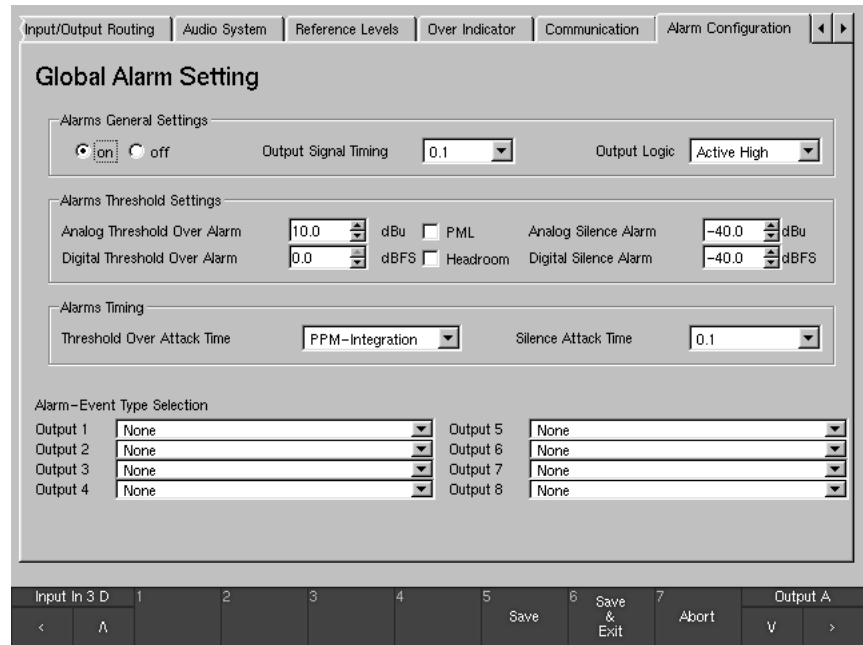

Fig. 4-26: The Alarm Configuration menu tab in Surround mode

### 4.11.1 Alarms General Settings

(See Fig. 4-26)

- **On/Off**

With these option boxes the alarm functions can be activated (On) or deactivated (Off).

When the alarm functions are activated the preset threshold levels are marked with small triangles right beside the bargraphs of the peakmeter. The identified events are displayed in the display areas of the Digital Over indicator (see Figs. 4-27 and 4-28 on the next page) for each channel without any weighting. The alarm events also can be output via the outputs of the GP IO interface (see Chapter 2.3.11).

See Figs. 4-27 and 4-28



See Chapter 2.3.11



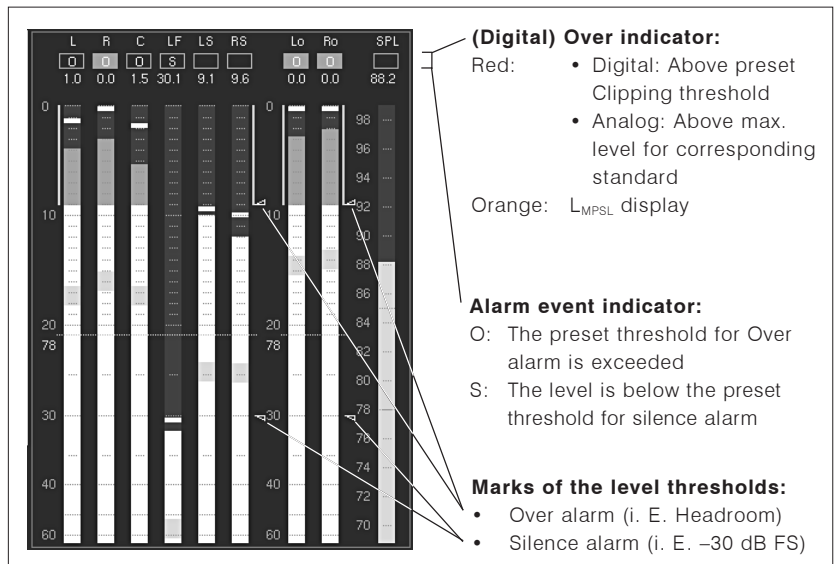

Fig. 4-27: Display elements of the Peakmeter instruments (PPM) alarm functions in Surround mode

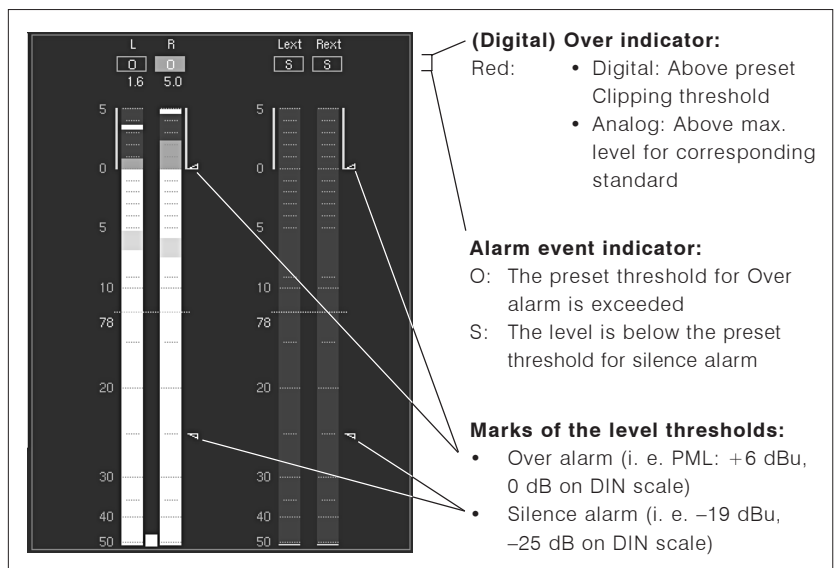

Fig. 4-28: Display elements of the Peakmeter instruments (PPM) alarm functions in 2 Channel Stereo mode

See Chapter 3.4



• **Output Signal Timing**

This combo box is for the selection of the time period of the display or output impulse activated when an alarm event is identified.

- The event output remains active after the time period (0.1, 0.5, 1, 2, 4 s) has passed when the conditions for the alarm event are still or again complied.
- Selecting Hold the active state is kept until a reset with the Reset button/key 2 of the PPM instrument (see Chapter 3.4) is made.
- Selecting Event keeps the output active as long as the condition for the alarm event is complied.

Using the Alarm-Event Type Selection function (see Chapter 4.11.4) the impulses can be put out.

• **Output Logic**

With this combo box you can define the logical state of the active event outputs: Active Low or Active High.

### 4.11.2 Alarms Threshold Settings

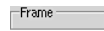

(See Fig. 4-26)

• **Analog Threshold Over Alarm**

This list box is for setting the Over level threshold in **dBu**. **Exceeding** this threshold will activate the alarm event Over for the time period selected with Alarms Timing (see Chapter 4.11.3).

Values in the range from +18 dBu to -55 dBu can be selected in 0.5 dB steps.

• **PML**

This check box activates the Permitted Maximum Level, the full conduction of "0 dB". The alarm event Over will be activated when the PML value of the displayed peakmeter is exceeded. This value depends on the current scale (see example in Fig. 4-28).

With activated PML check box the selected value for Analog Threshold Over Alarm has no function.

See example in Fig. 4-28



• **Analog Silence Alarm**

This list box is for setting the Silence level threshold in **dBu**. **Falling below** this threshold will activate the alarm event Silence for the time period selected with Alarms Timing (see Chapter 4.11.3).

Values in the range from 0 dBu to -60 dBu can be selected in 0.5 dB steps.



• **Please note:**

The threshold value is indicated in **dBu** as absolute level.

The setting of the Analog Metering Reference Level Offset list box on the Reference Levels menu tab (see Chapter 4.8) has no effect to the supplied threshold values.

See Chapter 4.8



• **Digital Threshold Over Alarm**

This list box is for setting the Over level threshold in **dB FS**. **Exceeding** this threshold will activate the alarm event Over for the time period selected with Alarms Timing (see Chapter 4.11.3).

Values in the range from 0 dB FS to -55 dB FS can be selected in 0.5 dB steps.

See examples in Fig. 4-27



• **Headroom**

With this check box activated the alarm event Over will be activated when the Headroom value of the displayed peakmeter is exceeded (see example in Fig. 4-28).

With activated Headroom check box the selected value for Analog Threshold Over Alarm has no function.

• **Digital Silence Alarm**

This list box is for setting the Silence level threshold in **dB FS. Falling below** this threshold will activate the alarm event Silence for the time period selected with Alarms Timing (see Chapter 4.11.3).

Values in the range from -10 dB FS to -55 dBu can be selected in 0.5 dB steps.

### 4.11.3 Alarms Timing

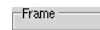

(See Fig. 4-26)

• **Threshold Over Attack Time**

This combo box is for the selection of the time period for the threshold condition (see Chapter 4.11.2) before the alarm event Over is activated. Available are:

- 0.1, 0.5, 1, 2 or 4 seconds
- PPM-Integration, this means that the current integration time of the displayed peakmeter is used without any weighting.

• **Silence Attack Time**

This combo box is for the selection of the time period for the threshold condition (see Chapter 4.11.2) before the alarm event Silence is activated. Available are the values 0.1, 0.5, 1, 2, 4 or 8 seconds.

### 4.11.4 Alarm-Event Type Selection

(See Figs. 4-26 and 29)

The following eight combo boxes are for the definition of which alarm event type routed to which output of the GP IO interface (see Chapter 2.3.11). The table on the next page (Fig. 4-29) shows the assignments.

See Fig. 4-29



Thereby means:

- **Threshold Over:** Exceeding the upper threshold value activates the alarm event Over according to the settings.
- **Digital Over:** Meeting or exceeding the above preset clipping threshold Digital Over activates the alarm event according to the settings.
- **Silence:** Falling below the lower threshold value activates the alarm event Silence according to the settings.

See Fig. 4-26



Output	Options selectable	Function
Output 1	<input type="text"/>	
	None Front Threshold Over Front Digital Over Front Silence	Alarm release, when the level of the front channels reaches the threshold marks
Output 2	<input type="text"/>	
	None Rear Threshold Over Rear Digital Over Rear Silence	Alarm release, when the level of the rear channels reaches the threshold marks
Output 3	<input type="text"/>	
	None Any Surround Ch Threshold Over Any Surround Ch Digital Over Any Surround Ch Silence	Alarm release, when the level of any surround channel reaches the threshold marks
Output 4	<input type="text"/>	
	None 2 Ch Downmix Threshold Over 2 Ch Downmix Digital Over 2 Ch Downmix Silence	Alarm release, when the level of the internal downmix channels reaches the threshold marks
Output 5	<input type="text"/>	
	None Ext Threshold Over Ext Digital Over Ext Silence	Alarm release, when the level of the external signals reaches the threshold marks
Output 6	<input type="text"/>	
	None L/R Threshold Over L/R Digital Over L/R Silence	Alarm release, when the level of the L and R channels reaches the threshold marks
Output 7	<input type="text"/>	
	None LF Threshold Over LF Digital Over LF Silence	Alarm release, when the level of the LF channel reaches the threshold marks
Output 8	<input type="text"/>	
	None Digital Over Channel 1 - 8 "ored" Digital Over Surround Ch "ored"	Alarm release, when the level of one channel reaches the digital over mark

Fig. 4-29: Selection of the alarm event type options (Alarm-Event Type Selection) in Surround mode



## 4.12 The Key Settings Menu

(See Fig. 4-30)

See Chapters 3.1. and 2.3.11. 

The options in this menu tab preset which single key, key groups (see Chapter 3.1.) or control inputs of the GP IO interface (see Chapter 2.3.11.) can be locked or configured with different functions.



**Please note:** The operation of the SurroundControl 30900(-24) with an optional computer mouse is always possible.

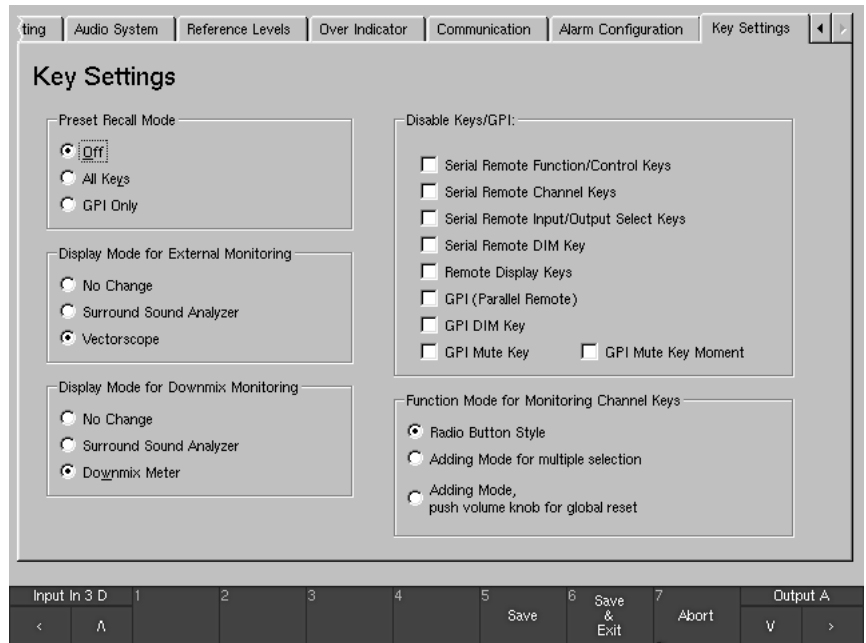



Fig. 4-30: The Key Settings menu tab

### 4.12.1 Preset Recall Mode

(See Fig. 4-30)

- **Off** 

With this option button activated all keys and control inputs have normal functions as described in the several chapters of this operating manual (see Chapters 3.1 and 2.3.11).

See Chapters 3.1 and 2.3.11 

- **All Keys** 

With this option button activated the buttons/keys 1 to 7 (see Chapter 3.1) of the Remote Control 30050, of the Remote Display 30010 and the corresponding control inputs of the GP IO interface (see Chapter 2.3.11) can be used for User Preset selection U 1 to U 7. The control keys MODE, MORE and INSTR are locked out (grey font, see Fig. 4-31) in this mode.

See Chapter 3.1 

See Chapter 2.3.11 



Fig. 4-31: Toolbar with All Keys option in Key settings menu activated

See Chapters 3.1 and 2.3.11



• **GPI only**

With this option button activated the corresponding control inputs of the GP IO interface (see Chapters 2.3.16 and 3.1) can be used only for the User Presets selection 1 U to 7 U. The keys of the Remote Control 30050, of the Remote Display 30010 and the corresponding buttons of the Toolbar keep their normal function.

### 4.12.2 Display Mode for External Monitoring



(See Fig. 4-30)

The following three option buttons allow an automatic call of another instrument when using the 2-Ch-Extern-to-Front function with the EX key on the Remote Control 30050 (see Chapter 3.15.7).

See Chapter 3.15.7



• **No Change**

Pressing the EX key (see Chapter 3.15.7.) only switches the external channels to the front loudspeakers (2-Ch-Extern-to-Front), no other instrument is called.

• **Surround Sound Analyzer**

Pressing the EX key (see Chapter 3.15.7.) automatically calls the Surround Sound Analyzer instrument (SSA, see Chapters 1.6.3 and 3.6) in 2-channel mode while switching the external channels to the front loudspeakers. Now this instrument is shown in Window 3 of the display with only the L and R channels active. When the 2-Ch-Extern-to-Front function (EX key, see Chapter 3.15.7) is deactivated the display returns to the previous mode.

• **Vectorscope**

Pressing the EX key (see Chapter 3.15.7.) automatically calls the Vectorscope instrument (see Chapters 1.6.3 and 3.6, settings with the Extern menu see Chapter 4.4.4) in 2-channel mode while switching the external channels to the front loudspeakers. Now this instrument is shown in Window 3 of the display. When the 2-Ch-Extern-to-Front function (EX key, see Chapter 3.15.7) is deactivated the display returns to the previous mode.

Instrument: see Chapters 1.6.3 and 3.6



Settings: see Chapter 4.4.4

### 4.12.3 Display Mode for Downmix Monitoring



(See Fig. 4-30)

The following three option buttons are for the selection of the automatically call of another instrument when using the 2-Ch-Downmix-to-Front function with the 2C key on the Remote Control 30050 (see Chapter 3.15.6).

See Chapter 3.15.6



• **No Change**

Pressing the 2C key (see Chapter 3.15.7.) only switches the downmix channels to the front loudspeakers (2-Ch-Downmix-to-Front), no other instrument is called.

- **Surround Sound Analyzer** 

Pressing the 2C key (see Chapter 3.15.6.) automatically calls the Surround Sound Analyzer instrument (SSA, see Chapters 1.6.3 and 3.6) in 2-channel mode while switching the downmix channels to the front loudspeakers. Now this instrument is shown in Window 3 of the display with only the L and R channels active. When the 2-Ch-Downmix-to-Front function (2C key, see Chapter 3.15.6) is deactivated the display returns to the previous mode.

- **Downmix Meter** 

Pressing the 2C key (see Chapter 3.15.6.) automatically calls the 2-Channel Downmix Meter instrument (see Chapters 1.6.7 and 3.9, settings with the Two Channel Downmix menu see Chapter 4.4.3) while switching the downmix channels to the front loudspeakers. Now this instrument is shown in Window 3 of the display. The settings of the Peakmeter - Channel Group menu (see Chapter 4.13) are used for the peakmeter display. When the 2-Ch-Downmix-to-Front function (2C key, see Chapter 3.15.6) is deactivated the display returns to the previous mode.

Instrument: see Chapters 1.6.7 and 3.9   
 Settings: see Chapter 4.4.3

See Chapter 3.15 and 2.3.16 

#### 4.12.4 Disable Keys/GPI

(See Fig. 4-30)

Keys, key groups or control inputs of the GPI/O interface (see Chapter 2.3.16) selectively can be locked.

- **Serial Remote Functions/Control Keys**

Activating this check box locks the function and control keys of the Remote Control 30050. The message "Serial Remote function and control keys disabled" is displayed in the Toolbar of the display when using one of the deactivated keys.

- **Serial Remote Channel Keys**

Activating this check box locks the channel keys (see Fig. 3-29) of the Remote Control 30050 (see Chapters 3.15 and 3.1). These are in detail for the:

- 5.1 format: L, C, R, LS, RS, LF, CS and M key
- 6.1 format: L, C, R, LS, RS, LF, CS and M key
- 7.1 format: L, 2C, C, EX, R, LS, RS, LF, CS and M key

The message "Serial Remote channel keys disabled" is displayed in the Toolbar of the display when using one of the deactivated keys.

See Chapter 3.15 and 3.1 

- **Serial Remote Input/Output Select Keys**

Activating this check box locks the corresponding keys for the Monitoring (see Figs. 3-1 and 3-29) of the Remote Control 30050 (see Chapters 3.15 and 3.1). These are in detail for the:

- 5.1 format: 2C, EX, Input and Output key
- 6.1 format: 2C, EX, Input and Output key
- 7.1 format: Input and Output key

The message "Serial Remote input select keys disabled" is displayed in the Toolbar of the display when using one of the deactivated keys.

See Chapter 3.15 and 3.1 

- **Serial Remote DIM Key**

Activating this check box locks the DIM key (see Figs. 3-1 and 3-29) of the Remote Control 30050 (see Chapters 3.15 and 3.1). The message "Serial Remote DIM key disabled" is displayed in the Toolbar of the display when using the deactivated key.

See Chapter 3.15 and 3.1 

- See Chapter 3.1 

  - **Remote Display Keys**

Activating this check box locks the function and control keys of the Remote Display 30010 (see Chapter 3.1). The message “Remote display keys disabled” is displayed in the Toolbar of the display when using one of the deactivated keys.
  
- See Chapter 2.3.16 

  - **GPI (Parallel Remote)**

Activating this check box locks the control inputs of the GP IO interface (see Chapter 2.3.16) except the DIM function control input. The message “GPI disabled” is displayed in the Toolbar of the display when using one of the deactivated control inputs.
  
- See Chapter 2.3.16 

  - **GPI DIM Key**

Activating this check box locks the DIM function control input of the GP IO interface (see Chapter 2.3.16). The message “GPI DIM key (parallel remote) disabled” is displayed in the Toolbar of the display when using the deactivated control input.
  
- See Chapter 2.3.16 

  - **GPI Mute Key**

Activating this check box locks the external Mute on/off function control input of the GP IO interface (pin 16, see Chapter 2.3.16). The message “GPI Mute key (parallel remote) disabled” is displayed in the Toolbar of the display when using the deactivated control input.
  
- See Chapter 2.3.16 

  - **GPI Mute Key Moment**

Activating this check box switches the external Mute on/off function control input of the GP IO interface (pin 16, see Chapter 2.3.16) from permanent operation to momentary operation. The Mute function only remains active as long as you press the GP IO control input key (pin 16).

#### 4.12.5 Function Mode for Monitoring Channel Keys

(See Fig. 4-30)

- See Fig. 3-29 
- With these option buttons the operating behaviour of the channel keys of the Remote Control 30050 (see Fig. 3-29) can be influenced .
- **Radio Button Style**

Activating this option button the channel keys of the Remote Control 30050 get toggle function to each other. A pressed key is deactivated automatically as soon as another key is pressed. There is only one key active at a time.
  
  - **Adding Mode for multiple selection**

With this option button activated several channel keys can be selected one after the other. One selected key can be reset when it is pressed again. Not until one of the 2C, EX or M keys is pressed all the activated channel keys are set back.
  
  - **Adding Mode, push volume knob for global reset**

With this option button activated several channel keys can be selected one after the other. All activated channel keys can be set back by pressing the volume dial of the Remote Control 30050 (see Fig. 3-29 and Chapter 3.15.11).
- See Fig. 3-29 and Chapter 3.15.11 

- Instrument Settings
- Edit selected preset
- Peakmeter
- Channel Mode Surround:
  - → Channel Group 1 - 3
  - → Two Channel Downmix
  - Channel Group

## 4.13 Channel Group Settings in Channel mode Surround

(Instrument Settings/Peakmeter - see Chapter 4.4.2  
Instrument Settings/Two Channel Downmix – see Chapter 4.4.3)

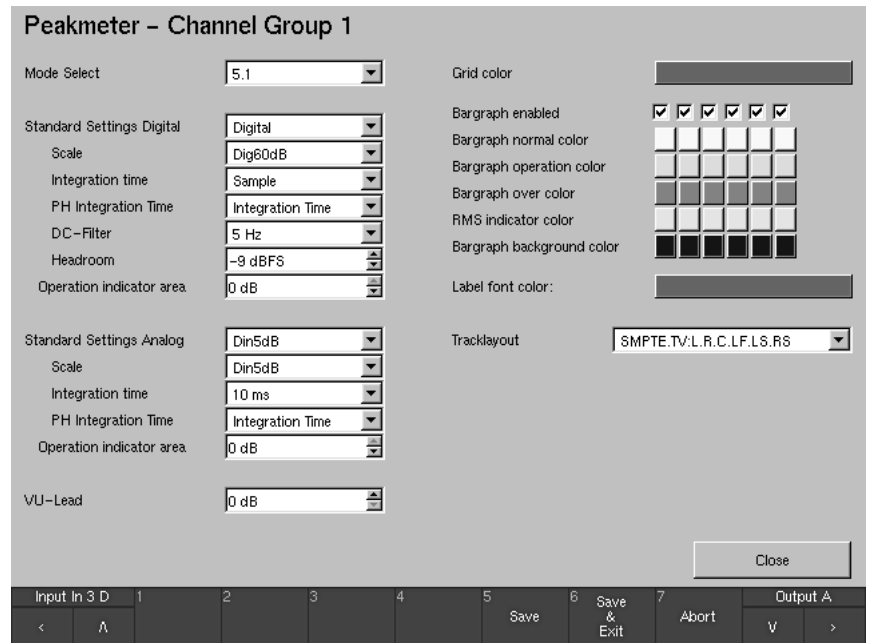

Fig. 4-32: The Peakmeter - Channel Group 1 menu page

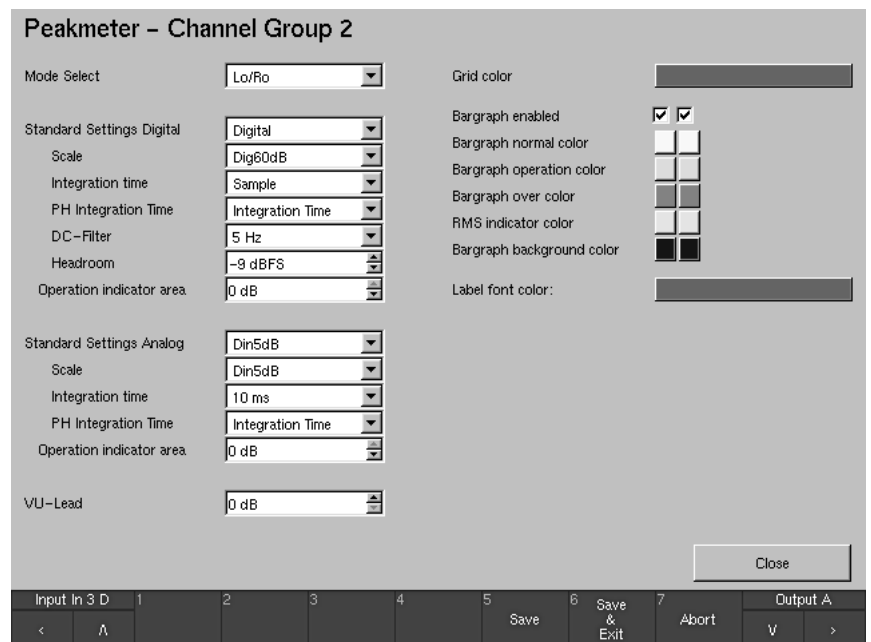

Fig. 4-33: The Peakmeter - Channel Group 2 menu page

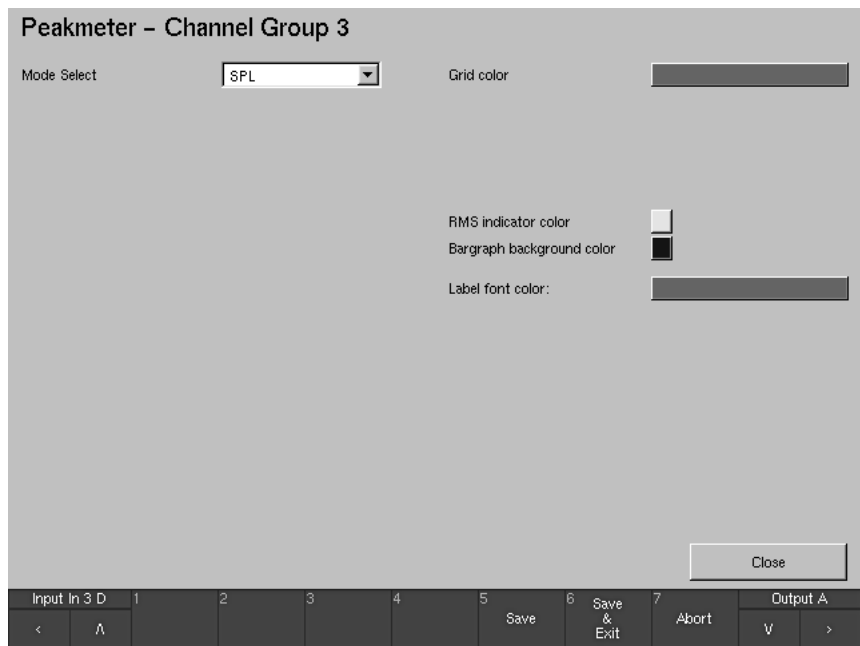

Fig. 4-34: The Peakmeter - Channel Group 3 menu page

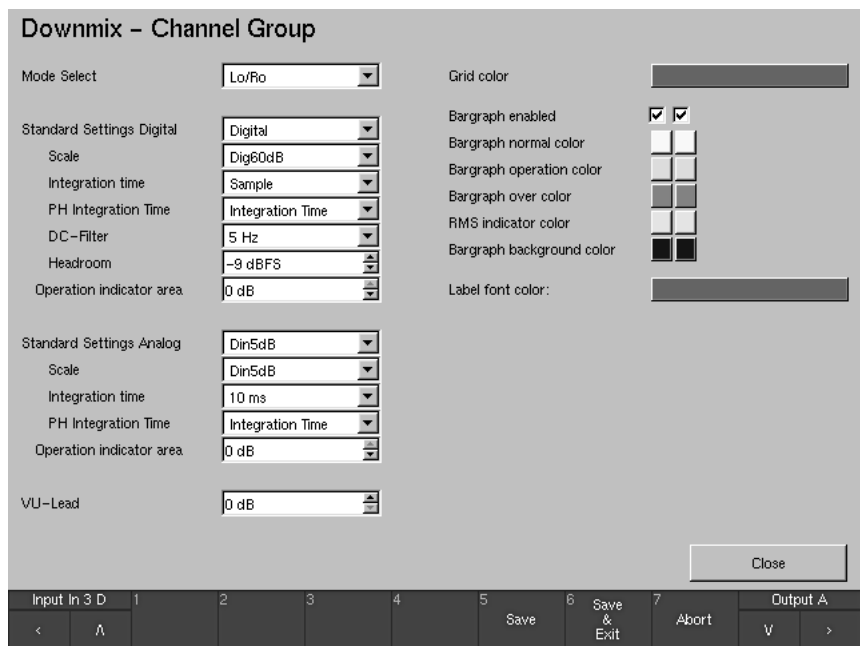

Fig. 4-35: The Downmix - Channel Group menu page

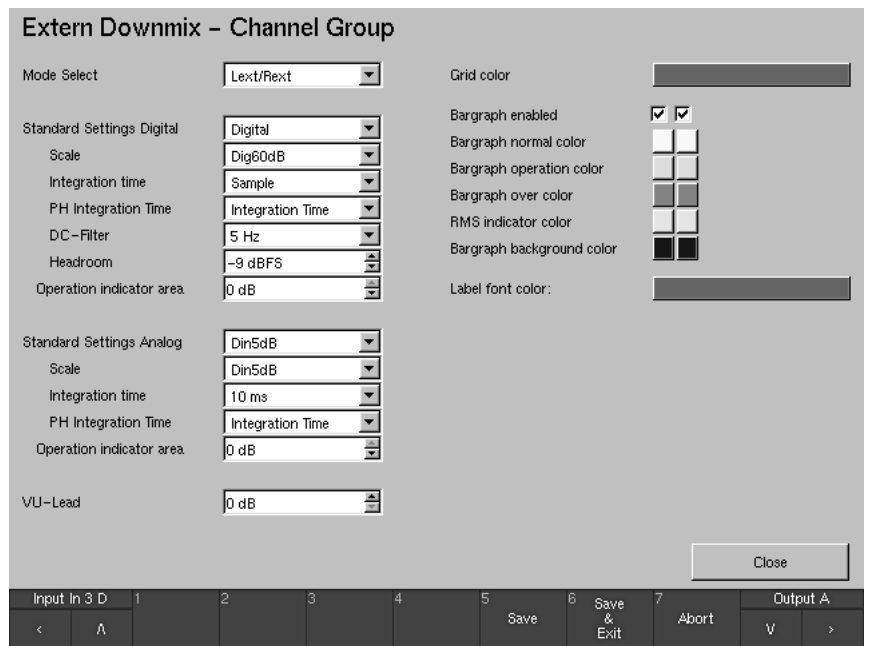

Fig. 4-36: The Extern Downmix - Channel Group menu page

See Chapters 4.4.2 and 4.4.3



In the Peakmeter menu tab there are three buttons labelled Channel Group 1, Channel Group 2 and Channel Group 3. In the Two Channel Downmix menu tab there is one button labelled Channel Group. These buttons display the peakmeter display settings menu pages for the corresponding channel groups. These pages, which all have more or less the same structure (see Figs. 4-32 to 4-36), contain the settings for the operating modes, standard settings for the digital and analog signal paths, VU Lead and the display colors for the individual elements.

See Chapters 4.4.2 (also 1.6.1)



There is also a special function on the **Peakmeter - Channel Group 1** menu page: The **Mode Select** combo box in this page (see Fig. 4-32) sets the **surround mode** for the operation of the peakmeters and thus also the display modes for the individual instruments. The display uses the channel assignments set in the routing settings.

If you have connected the optional mouse to the SurroundControl 30900(-24) you can display the Peakmeter Settings menu tab directly by clicking in Window 2 with the right mouse button when the unit is in normal mode. You can then change the surround format quickly by clicking on the Channel Group 1 button and selecting a different format with the Mode Select combo box.

The individual options are listed below. With some exceptions they apply for all groups. The exceptions and individual differences are all explained explicitly where applicable.

See above and  
Chapter 4.4.2 (also 1.6.1)



• **Mode Select**

These combo boxes are used to select the display mode for the corresponding channel groups. The available options vary depending on the channel group:

- Peakmeter - Channel Group 1: In this group you can select the surround formats 5.1, 6.1 and 7.1. **The setting in this group defines the basic operating mode of the SurroundControl 30900(-24)** (see the explanations above and in Chapters 4.4.2 and 1.6.1).
- Peakmeter - Channel Group 2: In this group you can select the downmix signals that are either generated from the surround formats set in the menu Peakmeter - Channel Group 1 or input from an external source. The available signals you can select for display are  $L_0/R_0$ ,  $L_{ext}/R_{ext}$ ,  $L_0/R_0 + \text{Sum/Diff}$  and  $L_{ext}/R_{ext} + \text{Sum/Diff}$ .
- Peakmeter - Channel Group 3: This peakmeter group is reserved for the SPL display.
- Downmix - Channel Group: This channel group is displayed in the Two Channel Downmix Meter (see Chapters 1.6.7 and 3.9) in Window 3 of the screen display, in addition to the peakmeter groups of the PPM instrument (Window 2). Shown are the internal downmix signals  $L_0/R_0$ .
- Extern Downmix - Channel Group: This channel group is displayed in the Two Channel Downmix Meter (see Chapters 1.6.7 and 3.9) in Window 3 of the screen display, in addition to the peakmeter groups of the PPM instrument (Window 2). Shown are the external downmix signals  $L_{ext}/R_{ext}$ .

• **Standard Settings Digital**

(Does NOT apply for Peakmeter - Channel Group 3)

This combo box applies to the four combo boxes and two list boxes grouped directly below it (see Figs. 4-32, 4-33, 4-35 and 4-36).

When you select Digital or ARD all these boxes are automatically set to values corresponding to the digital or the ARD standards. If you then change any of the settings of these boxes manually the text Non Standard is displayed in the Standard Settings Digital combo box. Reselecting Digital or ARD automatically resets all six boxes grouped below to the standard values of these presets.



• **Scale**

(Does NOT apply for Peakmeter - Channel Group 3)

This combo box allows you to select the available scales:

- Dig 60 dB (digital standard setting)
- Dig 20 dB
- Dig +18 dB .. 0 dB
- Dig +18 dB .. 0 .. -18 dB
- Dig +20 dB .. 0 .. -40 dB
- ARD +9 dB .. -60 dB
- <q> DIN 5 dB (quasi-DIN scale)
- <q> DIN 10 dB (quasi-DIN scale)
- <q> Zoom +/- 10 dB (quasi-DIN scale)
- <q> Zoom +/- 1 dB (quasi-DIN scale)
- <q> Nordic (quasi-Nordic scale)

• **Integration time**

(Does NOT apply for Peakmeter - Channel Group 3)

This combo box allows you to select the integration time of the level display:

- 10 ms
- 20 ms
- 1 ms
- 0.1 ms
- Sample (digital standard setting)

• **PH Integration Time**

(Does NOT apply for Peakmeter - Channel Group 3)

This combo box sets the integration time for the peak hold display:

- Integration Time: Uses the same integration time as for the level display (digital standard setting).
- Sample: Uses a sample-precise integration time that is independent of the level display.

• **DC-Filter**

(Does NOT apply for Peakmeter - Channel Group 3)

This combo box sets the DC filter. You can switch the filter off (Off) or set it to 5 Hz (digital standard setting), 10 Hz or 20 Hz.

• **Headroom**

(Does NOT apply for Peakmeter - Channel Group 3)

This list box sets the beginning of the headroom in the range between -20 dB FS and -5 dB FS. The digital standard setting is -9 dB FS.

• **Operation indicator area**

(Does NOT apply for Peakmeter - Channel Group 3)

This list box sets the area over which the indicator for the operating area is activated. You can enter values between -20 dB and 0 dB. The digital standard setting is 0 dB.

• **Standard Settings Analog**

(Does NOT apply for Peakmeter - Channel Group 3)

This combo box applies to the three combo boxes and the one list box grouped directly below it (see Figs. 4-32, 4-33, 4-35 and 4-36).

If you select one of the standards listed below the boxes are automatically set to the values corresponding to the selected standard. If you then change any of the boxes manually the text Non Standard is displayed in the Standard Settings Analog combo box. If you then reselect one of the standards all the four boxes grouped below are automatically reset to the values corresponding to the selected standard.

The following analog standards are available:

- DIN 5 dB
- DIN 10 dB
- Nordic
- British IIa
- British IIb
- VU
- SMPTE (**only** with SurroundControl 30900-24)
- NHK (**only** with SurroundControl 30900-24)

**Only** for SurroundControl 30900-24!



• **Scale**

(Does NOT apply for Peakmeter - Channel Group 3)

This combo box allows you to select the scale you want to use:

- Din 5 dB (DIN standard setting)
- DIN 10 dB
- Nordic (Nordic standard setting)
- British IIa (British IIa standard setting)
- British IIb (British IIb & SMPTE standard setting)
- Vu (VU standard setting)
- Zoom +/- 10 dB
- Zoom +/- 1 dB
- SMPTE 24 dB – abs

**Only** available with SurroundControl 30900-24, when SMPTE/RP155 (+24 dBu) is selected as Reference Level Standard in the Reference Levels menu.

- SMPTE 20 dB – rel

**Only** available with SurroundControl 30900-24, when SMPTE/RP155 (+24 dBu) is selected as Reference Level Standard in the Reference Levels menu. The reference level for the 0 dB display is +4 dBu.

- NHK

**Only** available with SurroundControl 30900-24, when SMPTE/RP155 (+24 dBu) or User (+18 .. +24 dBu) is selected as Reference Level Standard in the Reference Levels menu. The reference level for the 0 dB display refers to the selected standard resp. to the individual selected reference level (see the User list box in the Reference Levels menu).

**Only** for SurroundControl 30900-24!



**Only** for SurroundControl 30900-24!



**Only** for SurroundControl 30900-24!



• **Integration time**

(Does NOT apply for Peakmeter - Channel Group 3)

This combo box sets the integration time for the level display:

- 10 ms (DIN, Nordic & SMPTE standard setting)
- 20 ms (British IIa & British IIb standard setting)
- 1 ms
- 0.1 ms
- 300 ms (VU standard setting)

Only for SurroundControl 30900-24 with NHK scale selected!



- **PH Integration Time**   
(Does NOT apply for Peakmeter - Channel Group 3)  
This combo box sets the integration time for the peak hold display:
  - Integration Time: Uses the same integration time as for the level display. This applies for all standard settings.
- **Headroom**   
(Only available with SurroundControl 30900-24 and with NHK scale selected, does NOT apply for Peakmeter - Channel Group 3)  
This list box sets the beginning of the headroom in the range between -20 dB and -5 dB. The standard setting is -9 dB.
- **Operation indicator area**   
(Does NOT apply for Peakmeter - Channel Group 3)  
This list box sets the area over which the indicator for the operating area is activated. You can enter values between -20 dB and 0 dB. A setting of 0 dB corresponds to 0 dB. The standard setting is 0 dB.
- **VU Lead**   
(Does NOT apply for Peakmeter - Channel Group 3)  
This list box is for setting the lead for the VU display. You can enter values between 0 dB and 10 dB.
- **Grid Color**   
This button displays the color selector so that you can change the color of the scale grid for the bargraph display.
- **Bargraph enabled**   
(Does NOT apply for Peakmeter - Channel Group 3)  
With these check boxes the display of each bargraph can be deactivated separately for every channel in the peakmeter display.
- **Bargraph normal color**   
(Does NOT apply for Peakmeter - Channel Group 3)  
These buttons display separately for every channel the color selector so that you can change the color of each bargraph in the peakmeter display.
- **Bargraph operation color**   
(Does NOT apply for Peakmeter - Channel Group 3)  
These buttons display separately for every channel the color selector so that you can change the color of the working range of each bargraph in the peakmeter display.
- **Bargraph over color**   
(Does NOT apply for Peakmeter - Channel Group 3)  
These buttons display separately for every channel the color selector so that you can change the color of the over range of each bargraph in the peakmeter display.
- **RMS indicator color**   
This button displays the color selector so that you can change the color of the RMS indicator of the bargraphs in the peakmeter display.

- **Bargraph background color**

These buttons display separately for every channel the color selector so that you can change the background color of each bargraph in the peakmeter display.

- **Label font color**

This button displays the color selector so that you can change the color of the text font used in the peakmeter display.

- **Track layout**

(Does ONLY apply for Peakmeter - Channel Group 3)

This combo box is for selecting the channel sequences of the bargraphs for the individual channel groups. The selection options are available for the 5.1 surround format, for the formats 6.1 and 7.1 the track layout is displayed:

For the selection of the format use the Mode Select combo box:

- 5.1: SMPTE.TV: L.R.C.LF.LS.RS  
SMPTE.FILM: L.LS.C.RS.R.LF  
DTS: L.R.LS.RS.C.LF  
FILM: L.C.R.LS.RS.LF  
L,C,R,LF,LS,RS
- 6.1: DTS: L.C.R.LS.DS.RS.LF
- 7.1: SMPTE: L.LC.C.RC.R.LS.RS.LF

- **Close**

This button closes the page and returns you to the menu page from which you selected the Channel Group.

- Instrument Settings
- Edit selected preset
- Peakmeter
- Channel Mode 2 Channel Stereo
  - → Channel Group 1 - 2

## 4.14 Channel Group Settings in Channel mode 2 Channel Stereo

(Instrument Settings/Peakmeter - see Chapter 4.4.2)

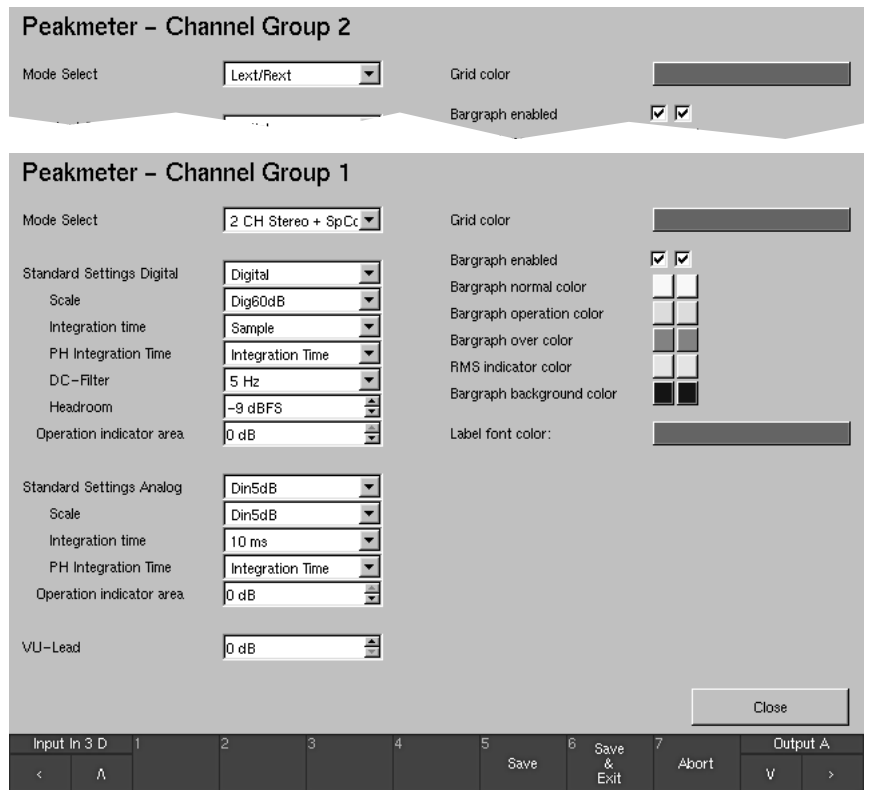

Fig. 4-37: The menu pages of the channel groups available in 2 Channel Stereo mode

See Chapter 4.4.2  
(also 1.6.1)



In the Peakmeter menu tab there are two buttons labeled Channel Group 1 and Channel Group 2.



These buttons display the peakmeter display settings menu pages for the corresponding channel groups. These pages, which all have the same structure (see Fig. 4-37), contain the settings for the operating modes, standard settings for the digital and analog signal paths, VU Lead and the display colors for the individual elements.

There is also a special function on the **Peakmeter - Channel Group 1** menu page: The **Mode Select** combo box in this page (see Fig. 4-37) displays **2 CH Stereo + SpCor**. It shows that the **2 Channel Stereo mode** is selected for the operation of the peakmeters and thus also presets the display modes for the individual instruments. The display uses the channel assignments set in the routing settings.

If you have connected the optional mouse to the SurroundControl 30900(-24) you can display the Peakmeter Settings menu tab directly by clicking in Window 2 with the right mouse button when the unit is in normal mode. You can then change the surround format quickly by clicking on the Channel Group 1 button and selecting a different format with the Mode Select combo box.

The individual options are listed below.

See above and  
Chapter 4.4.2 (also 1.6.1)



• **Mode Select**

These combo boxes are used to select the display mode for the corresponding channel groups:

- **Peakmeter - Channel Group 1:** 2 CH Stereo + SpCor is displayed (2 channel stereo with spot correlator). **These settings define the basic operating mode of the SurroundControl 30900(-24)** (see the explanations above and in Chapters 4.4.2 and 1.6.1).
- **Peakmeter - Channel Group 2:** In this group you can select the display of the external 2-channel signals in the Peakmeter instrument. The available signals you can select are  $L_{ext}/R_{ext}$  and  $L_{ext}/R_{ext} + \text{Sum/Diff}$ .

• **Standard Settings Digital**

This combo box applies to the four combo boxes and two list boxes grouped directly below it (see Fig 4-37).

When you select Digital or ARD all these boxes are automatically set to values corresponding to the digital or the ARD standards. If you then change any of the settings of these boxes manually the text Non Standard is displayed in the Standard Settings Digital combo box. Reselecting Digital or ARD automatically resets all six boxes grouped below to the standard values of these presets.

• **Scale**

This combo box allows you to select the available scales:

- Dig 60dB (digital standard setting)
- Dig 20dB
- Dig +18dB .. 0 dB
- Dig +18dB .. 0 .. -18 dB
- Dig +20dB .. 0 .. -40 dB
- ARD +9 dB .. -60 dB
- <q> DIN 5 dB (quasi-DIN scale)
- <q> DIN 10 dB (quasi-DIN scale)
- <q> Zoom +/- 10 dB (quasi-DIN scale)
- <q> Zoom +/- 1 dB (quasi-DIN scale)
- <q> Nordic (quasi-Nordic scale)

- **Integration time**

This combo box allows you to select the integration time of the level display:

- 10 ms
- 20 ms
- 1 ms
- 0.1 ms
- Sample (digital standard setting)

- **PH Integration Time**

This combo box sets the integration time for the peak hold display:

- Integration Time: Uses the same integration time as for the level display (digital standard setting).
- Sample: Uses a sample-precise integration time that is independent of the level display.

- **DC-Filter**

This combo box sets the DC filter. You can switch the filter off (Off) or set it to 5 Hz (digital standard setting), 10 Hz or 20 Hz.

- **Headroom**

This list box sets the beginning of the headroom in the range between -20 dB FS and -5 dB FS. The digital standard setting is -9 dB FS.

- **Operation indicator area**

This list box sets the area over which the indicator for the operating area is activated. You can enter values between -20 dB and 0 dB. The digital standard setting is 0 dB.

- **Standard Settings Analog**

This combo box applies to the three combo boxes and the one list box grouped directly below it (see Fig. 4-37).

If you select one of the standards listed below the boxes are automatically set to the values corresponding to the selected standard. If you then change any of the boxes manually the text Non Standard is displayed in the Standard Settings Analog combo box. If you then reselect one of the standards all the four boxes grouped below are automatically reset to the values corresponding to the selected standard.

The following analog standards are available:

- DIN 5 dB
- DIN 10 dB
- Nordic
- British IIa
- British IIb
- VU
- SMPTE (**only** with SurroundControl 30900-24)
- NHK (**only** with SurroundControl 30900-24)

**Only** for SurroundControl  
30900-24!



• **Scale**

This combo box allows you to select the scale you want to use:

- Din 5 dB (DIN standard setting)
- DIN 10 dB
- Nordic (Nordic standard setting)
- British IIa (British IIa standard setting)
- British IIb (British IIb & SMPTE standard setting)
- Vu (VU standard setting)
- Zoom +/- 10 dB
- Zoom +/- 1 dB
- SMPTE 24 dB – abs

**Only** available with SurroundControl 30900-24, when SMPTE/RP155 (+24 dBu) is selected as Reference Level Standard in the Reference Levels menu.

- SMPTE 20 dB – rel

**Only** available with SurroundControl 30900-24, when SMPTE/RP155 (+24 dBu) is selected as Reference Level Standard in the Reference Levels menu. The reference level for the 0 dB display is +4 dBu.

- NHK

**Only** available with SurroundControl 30900-24, when SMPTE/RP155 (+24 dBu) or User (+18 .. +24 dBu) is selected as Reference Level Standard in the Reference Levels menu. The reference level for the 0 dB display refers to the selected standard resp. to the individual selected reference level (see the User list box in the Reference Levels menu).

**Only** for SurroundControl 30900-24!



**Only** for SurroundControl 30900-24!



**Only** for SurroundControl 30900-24!



• **Integration time**

This combo box sets the integration time for the level display:

- 10 ms (DIN, Nordic & SMPTE standard setting)
- 20 ms (British IIa & British IIb standard setting)
- 1 ms
- 0.1 ms
- 300 ms (VU standard setting)

• **PH Integration Time**

This combo box sets the integration time for the peak hold display:

- Integration Time: Uses the same integration time as for the level display. This applies for all standard settings.

**Only** for SurroundControl 30900-24 with NHK scale selected!



• **Headroom**

(**Only** with SurroundControl 30900-24 and with NHK scale selected)

This list box sets the beginning of the headroom in the range between -20 dB and -5 dB. The standard setting is -9 dB.

• **Operation indicator area**

This list box sets the area over which the indicator for the operating area is activated. You can enter values between -20 dB and 0 dB. A setting of 0 dB corresponds to 0 dB. The standard setting is 0 dB.

• **VU Lead**

This list box is for setting the lead for the VU display. You can enter values between 0 dB and 10 dB.



- **Grid Color**

This button displays the color selector so that you can change the color of the scale grid for the bargraph display.

- **Bargraph enabled**

With these check boxes the display of each bargraph can be deactivated separately for every channel in the peakmeter display.

- **Bargraph normal color**

These buttons display separately for every channel the color selector so that you can change the color of each bargraph in the peakmeter display.

- **Bargraph operation color**

These buttons display separately for every channel the color selector so that you can change the color of the working range of each bargraph in the peakmeter display.

- **Bargraph over color**

These buttons display separately for every channel the color selector so that you can change the color of the over range of each bargraph in the peakmeter display.

- **RMS indicator color**

These buttons display separately for every channel the color selector so that you can change the color of the RMS indicator of each bargraph in the peakmeter display.

- **Bargraph background color**

These buttons display separately for every channel the color selector so that you can change the background color of each bargraph in the peakmeter display.

- **Label font color**

This button displays the color selector so that you can change the color of the text font used in the peakmeter display.

- **Close**

This button closes the page and returns you to the menu page from which you selected the Channel Group.



# 5 Software Update

## 5.1 General

With the SurroundControl 30900(-24) it is possible to update the operating system and the application by the use of a standard web-browser. It is also possible to import or export user preset data. The required software is available from RTW by request.



### Please note:

Basically any software update will delete and replace the user and factory presets by the initial presets predefined from RTW. **Please make a note of all user specific settings you have made to be able to reprogram them after the software update of the SurroundControl 30900(-24).** The export or the import of user defined settings (User Presets) with the software update program is only possible with an installed software version V 02.01.00 or higher!

Version number:  
→ MENU → General Settings  
see Chapter 4.5



Prepare for the software update as follows:

1. Copy all files that you have received into a folder (i. e. C:\30900\_update) on your PC that is assigned to be used for the update sequence.

See Chapter 2.3.4 and  
Figs. 2-1 and 2-2



2. Connect the SurroundControl 30900(-24) by the use of a standard cat-5 LAN network cable with RJ-45 connectors to your network environment.



If you decide to update the software not through the network but by the use of a directly connected PC to the SurroundControl 30900(-24), a cat-5 crossover cable with RJ-45 connectors must be used. Internet browser software must also be installed and ready to use on the PC.

3. Run the internet browser software and make sure that all necessary settings required for your networking setup are made.



If you decide to update the software not through the network but by the use of a directly connected PC to the SurroundControl 30900(-24), it is necessary to define the connection settings of your internet browser for not using a proxy server and not using scripts.

- Settings for the Microsoft Internet explorer have to be made in the menu:  
Extras/Internet options/Connections/LAN settings/Presets
- Settings for Netscape navigator (mozilla) have to be made in the menu:  
Edit/Presets/Advanced/Proxy

IP-Adress:  
→ MENU → Communication  
see Chapter 4.10



4. Look up the IP address of the SurroundControl 30900(-24) you like to update. This information can be found in the menu on the communications page (also see 4.10).

5. Close the menu mode of the SurroundControl 30900(-24) by the use of the Abort function.

The export is only possible with an **installed** version **V 02.01.00** or higher!



## 5.2 Proceeding the export of the User Presets

The following figures show the export sequence in more detail. For the following example sequence we assume that the IP address of your SurroundControl 30900(-24) is 192.168.103.202.

1. Start your internet browser and enter `http://192.168.103.202` in the address field (see Fig. 5-1) followed by the hit of the return (Enter) key.



Fig. 5-1: Entering the IP adress

2. The SurroundControl 30900(-24) should respond with a screen like the one shown in Fig. 5-2. Choose Export user settings. **Please note the instructions on the Export menu page** (see Fig. 5-3).

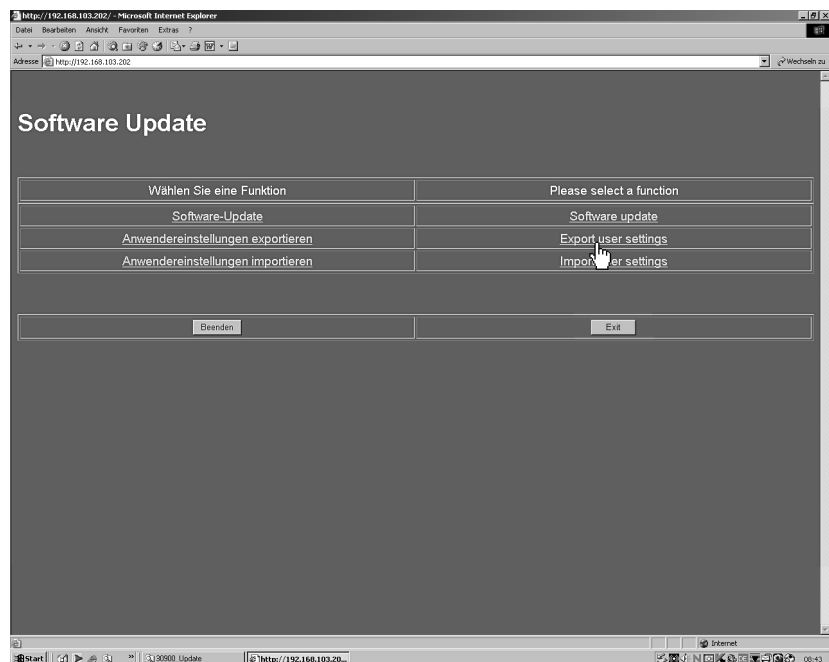

Fig. 5-2: Software Update Program menu in web browser

3. Please click the Exports button (see Fig. 5-3).

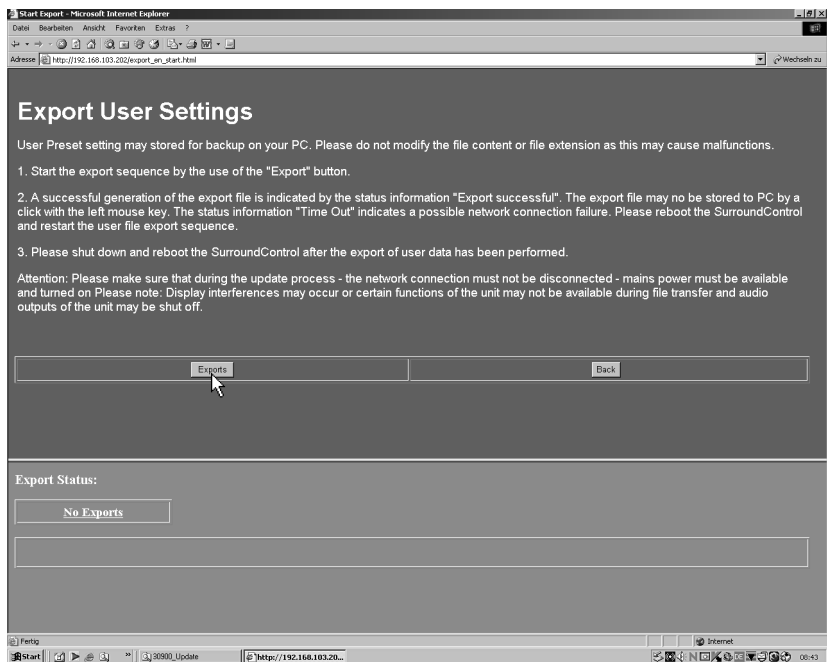

Fig. 5-3: Display of the Export menu page

4. The export of the user setting data starts (see Fig. 5-4). Generating Export File is displayed, a yellow bar is showing the progress of the export.

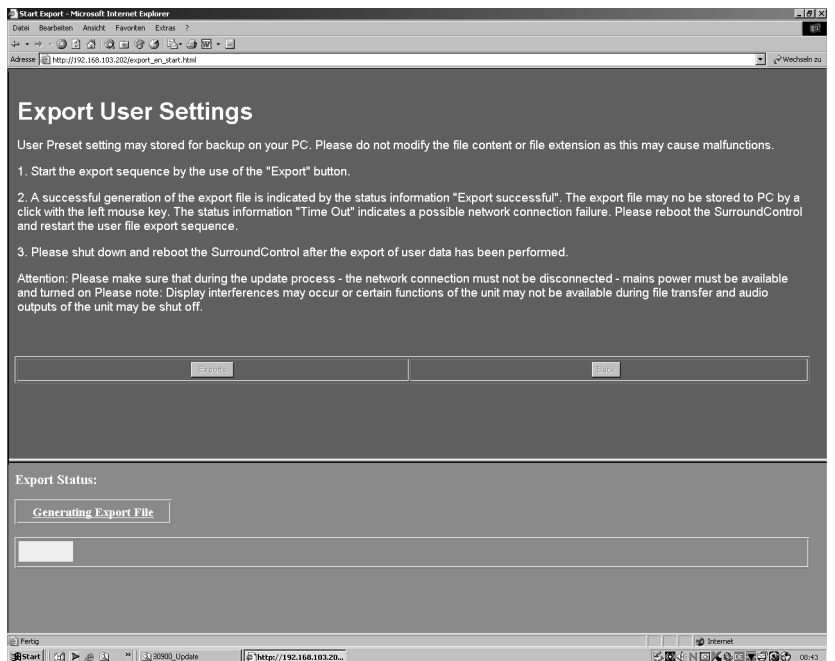

Fig. 5-4: The export is running

5. When the Export Status turns to the blue labelled „Export generiert“ (see Fig. 5-5) the export file can be saved. Please click „Export generiert“

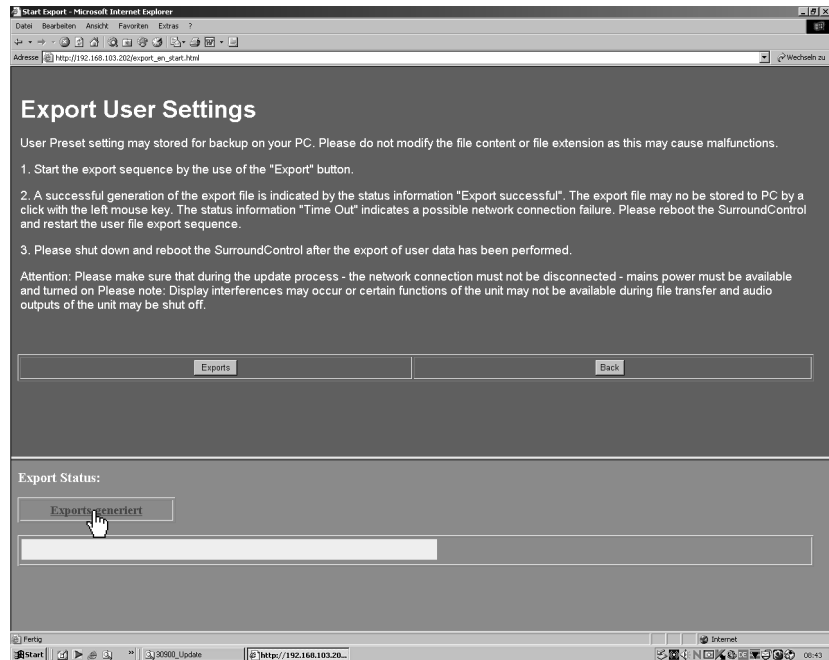

Fig. 5-5: The export file has been generated and can be saved

6. The file download dialog box appears (see Fig. 5-6). Please click Save („Speichern“).

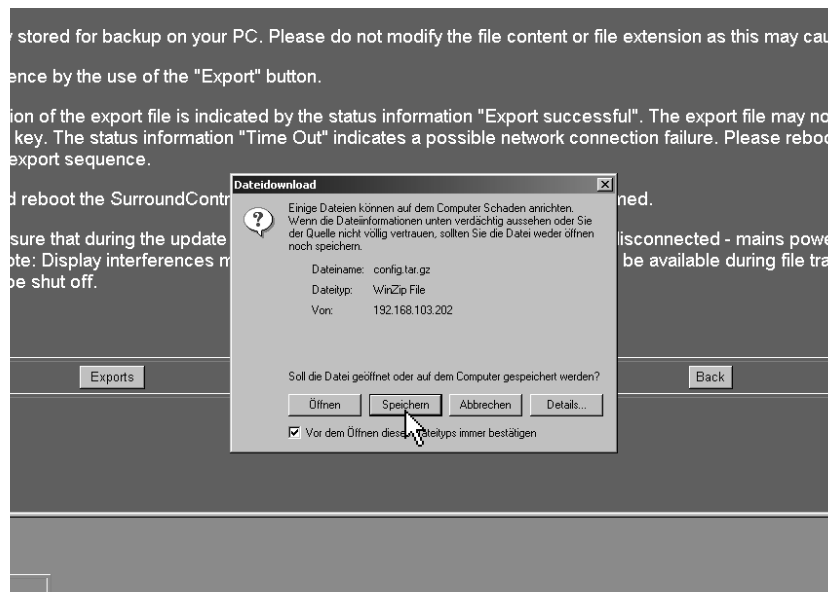

Fig. 5-6: The file download dialog

- The save file as („Datei speichern unter“) dialog box is shown. Choose the folder (i. e. C:\30900\_Update) for saving the export file config.tar.gz (see Fig. 5-7).

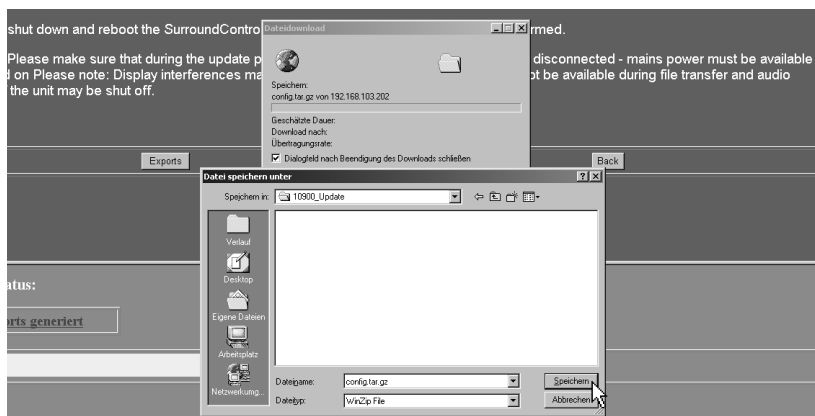

Fig. 5-7: Choose the folder for saving the export file

- When saving the file was successful please click the Back button (see Fig. 5-8) to get back to the home page (see Fig. 5-2).

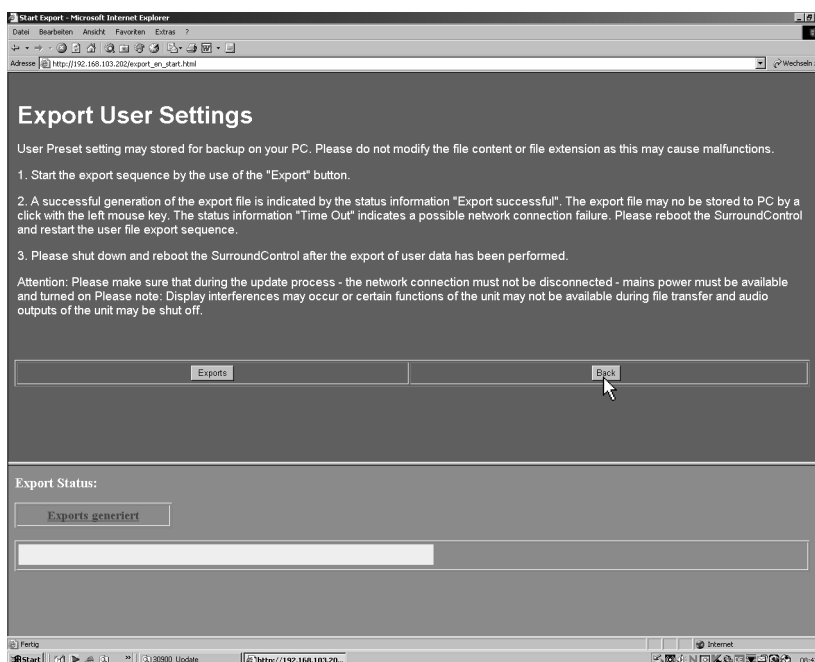

Fig. 5-8: End of the export process

- If you want to proceed a software update please click Software Update on the home page. Please follow the instructions of Chapter 5.3.
- If you want to leave the update program please click the Exit button (see Fig. 5-2). The SurroundControl 30900(-24) has to be restarted. Please wait approx 5 sec. after shut down of the unit before you power it up again.

## 5.3 Proceeding a Software Update

Version number:  
→ MENU → General Settings  
see Chapter 4.5



A complete software update requires **four** files to be replaced in the Surround-Control 30900(-24). **All four files must be used in the following order.** (xxxxxx represents the current software version code - also see 4.5 for details)

- „p30900\_xxxxxx\_ **BSYS**“
- „p30900\_xxxxxx\_ **FSYS**“
- „p30900\_xxxxxx\_ **RDIS**“
- „p30900\_xxxxxx\_ **CONF**“

After you have downloaded the first **three** files, the SurroundControl must be restarted.

The following figures show the software update sequence in more detail. **Please proceed them in the order described!**

1. Start your internet browser and enter the IP address in the address field (i. e.: <http://192.168.103.202>, see Fig. 5-9) followed by the hit of the return (Enter) key.



Fig. 5-9: Entering the IP-Adress

2. The SurroundControl should respond with a screen like the one shown in Fig. 5-2. Choose Software update.

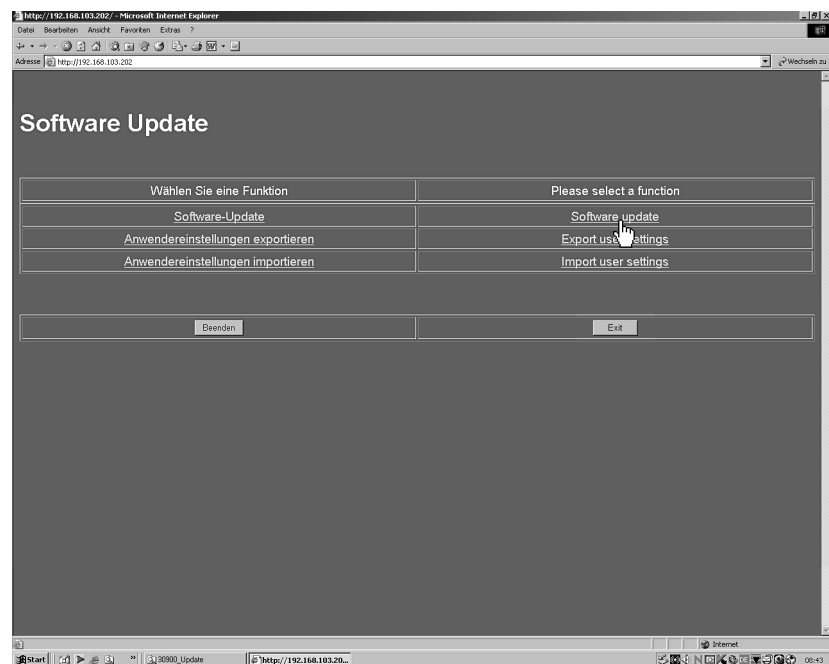

Fig. 5-10: Software Update Program menu in web browser



3. Select "Durchsuchen" (see Fig. 5-11).

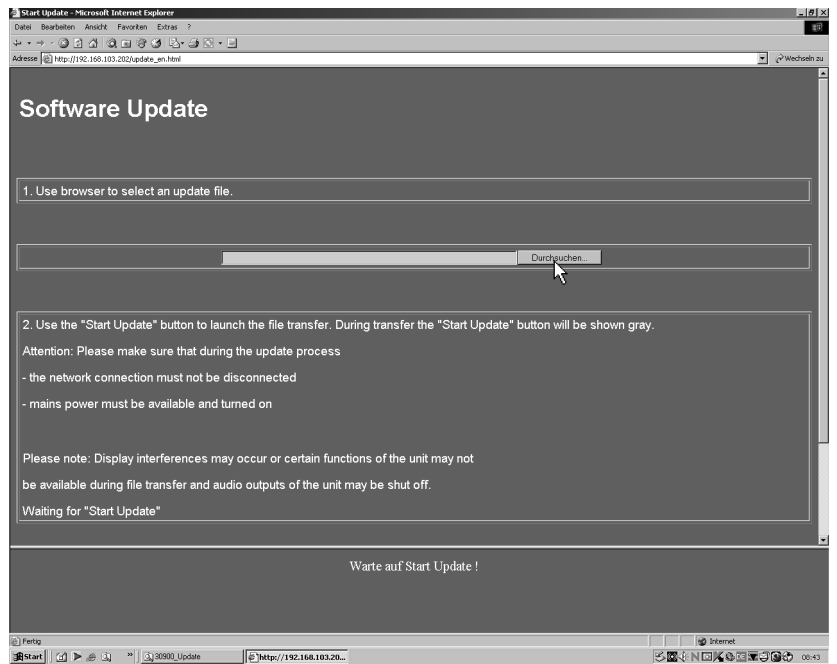

Fig. 5-11: Display of the Software Update menu page („Durchsuchen“)

4. Use the displayed dialog to select the directory path where you have stored the **four** update files. Select the file **p30900\_xxxxxx\_BSYS** first (see Fig. 5-12). xxxxxx represents the current software version code (also see 4.5 for details).

Version number:  
 → MENU → General Settings  
 see Chapter 4.5



**Please note:**

The use of mixed version codes is not permitted. Malfunctioning of the SurroundControl 30900(-24) may result.

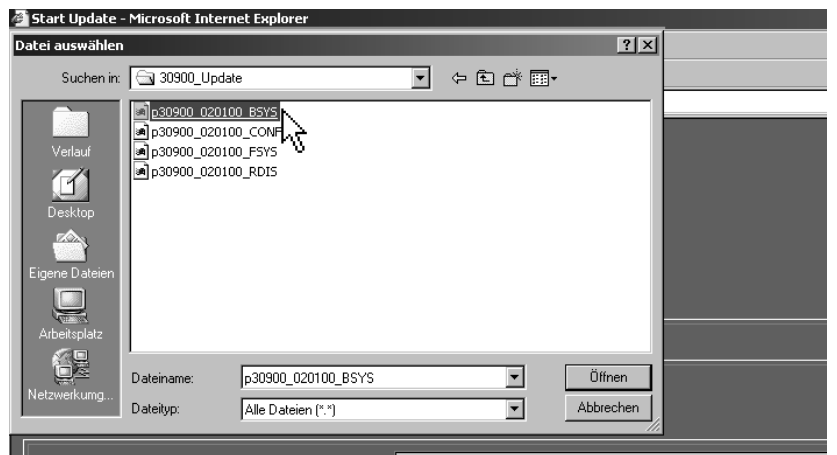

Fig. 5-12: The update file selection dialog box

- After selecting the update file move the menu page upward by moving downward the grey scrollbar on the right (see mouse pointer in Fig. 5-13).

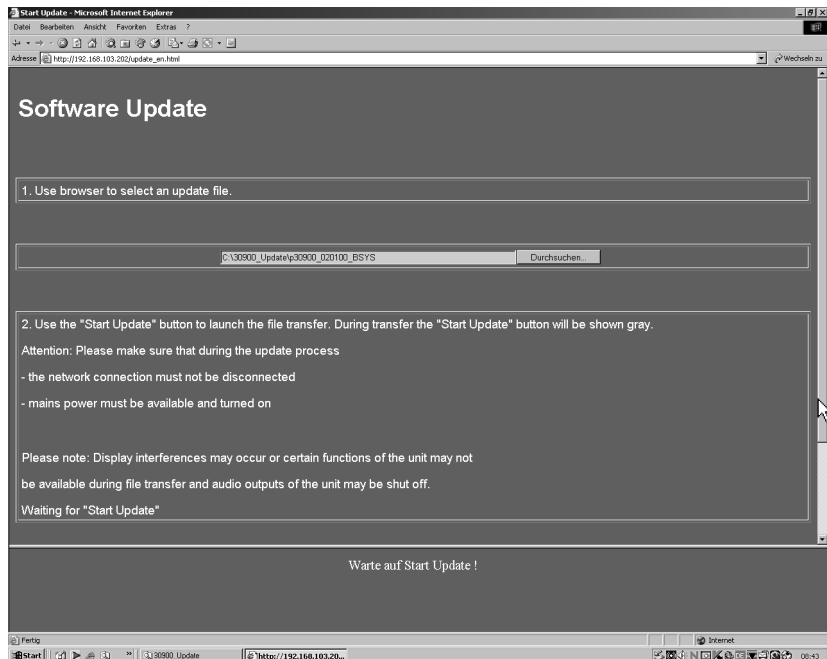

Fig. 5-13: Selection of the update file and moving the menu page with the scrollbar



- Press Start update to start the update process (see Fig. 5-14). **Please make sure that no interruption of the network access or supply power occurs during the download sequence.**

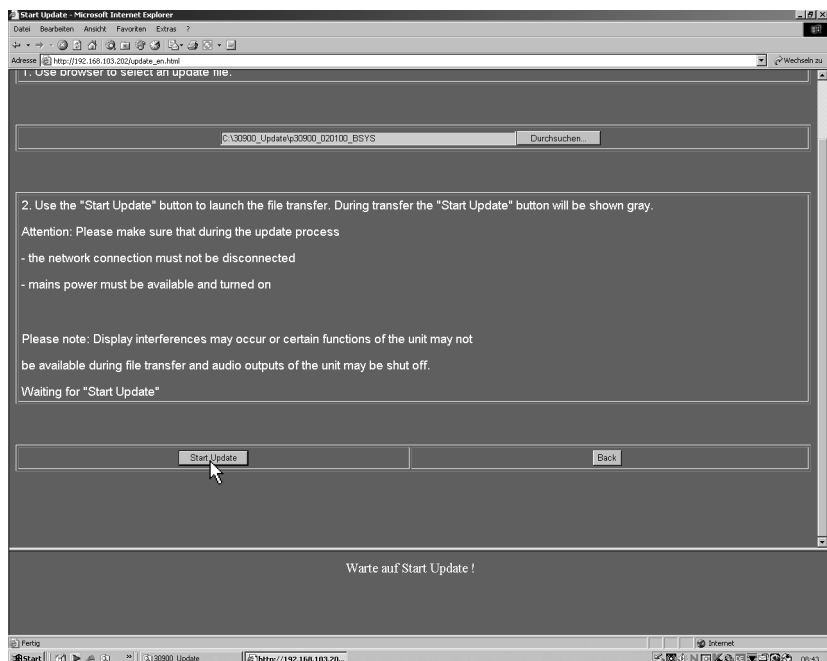

Fig. 5-14: Starting the update process with the selected update file

7. A bar on the lower end of the update window on the PC reads the data transfer progress (see Fig. 5-15).

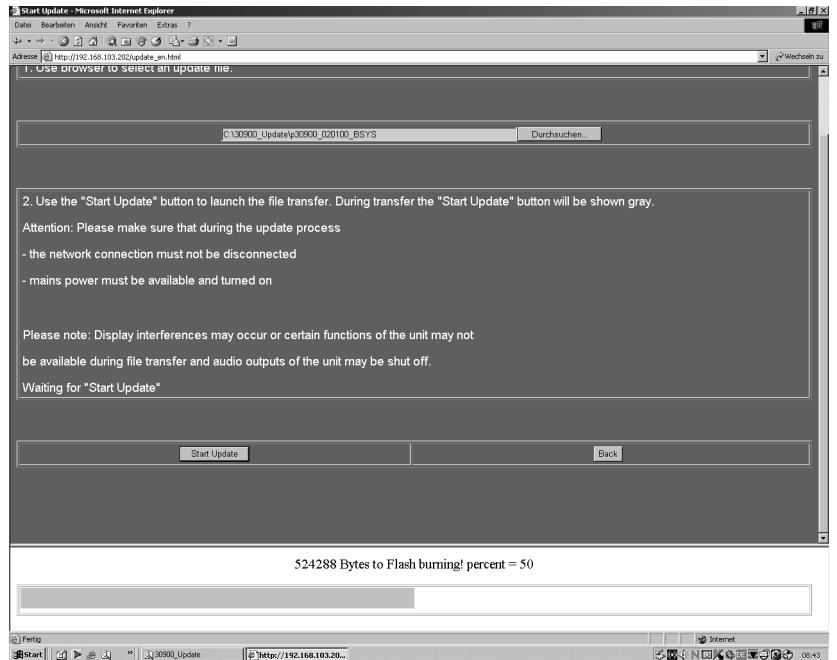

Fig. 5-15: Progress of the data transfer of the selected update file

8. The download is finished when the message "Please make power off" is displayed (see Fig. 5-16). Please do **not** switch off the SurroundControl 30900(-24) but proceed with step 9.

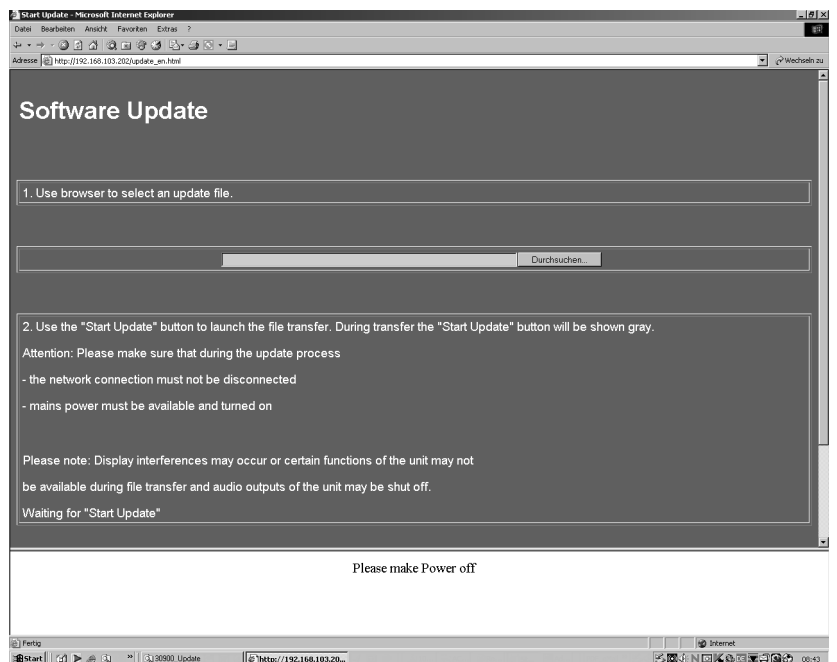

Fig. 5-16: End of the data transfer of the selected file

9. Use the displayed dialog (see Figs. 5-16 and 5-11) to select („Durchsuchen“) the **second** of the four update files.  
Select the file **p30900\_XXXXXX\_FSYS**. Repeat steps 4 to 8.

10. Use the displayed dialog (see Figs. 5-16 and 5-11) again to select („Durchsuchen“) the **third** of the four update files.  
Select the file **p30900\_XXXXXX\_RDIS**. Repeat steps 4 to 8.

A restart must be processed after **third** file transfer!



11. **Now** its time to **restart** the SurroundControl 30900(-24) **before** transferring the fourth update file. Please wait approx. 5 sec. after shut down of the unit before you power it up again.

12. After the SurroundControl 30900(-24) has rebooted re-establish the connection between your web browser and the SurroundControl 30900(-24) as described with steps 1 to 3.

13. Use the displayed dialog (see Fig. 5-11) to select („Durchsuchen“) the **fourth** of the four update files.  
Select the file **p30900\_XXXXXX\_CONF**. Repeat steps 4 to 8.

14. If the download of the p30900\_XXXXXX\_CONF file is completed you must **reboot** the SurroundControl 30900(-24) again. Please wait approx. 5 sec. after shut down of the unit before you power it up again.

Version number:  
→ MENU → General Settings  
see Chapter 4.5



15. After the SurroundControl 30900(-24) has rebooted its ready to use with the new software version. You will find the current used version code of the application in the About-info frame of the General settings menu.

16. If the software update was proceeded to an **installed** software version **V 02.01.00** and then updated to a **higher** version the exported user settings (see Chapter 5.2) now can be **imported**. Therefore please follow the instructions of Chapter 5.4!

The export is only possible with an **installed** version **V 02.01.00** or higher!



## 5.4 Proceeding the import of the User Presets

The following figures show the import sequence in more detail.

For the following example sequence we assume that the IP address of your SurroundControl 30900(-24) is 192.168.103.202.

1. Start your internet browser and enter `http://192.168.103.202` in the address field (see Fig. 5-17) followed by the hit of the return (Enter) key.



Fig. 5-17: Entering the IP-Adress

2. The SurroundControl 30900(-24) should respond with a screen like the one shown in Fig. 5-18. Choose Export user settings. **Please note the instructions on the Import menu page** (see Fig. 5-19).

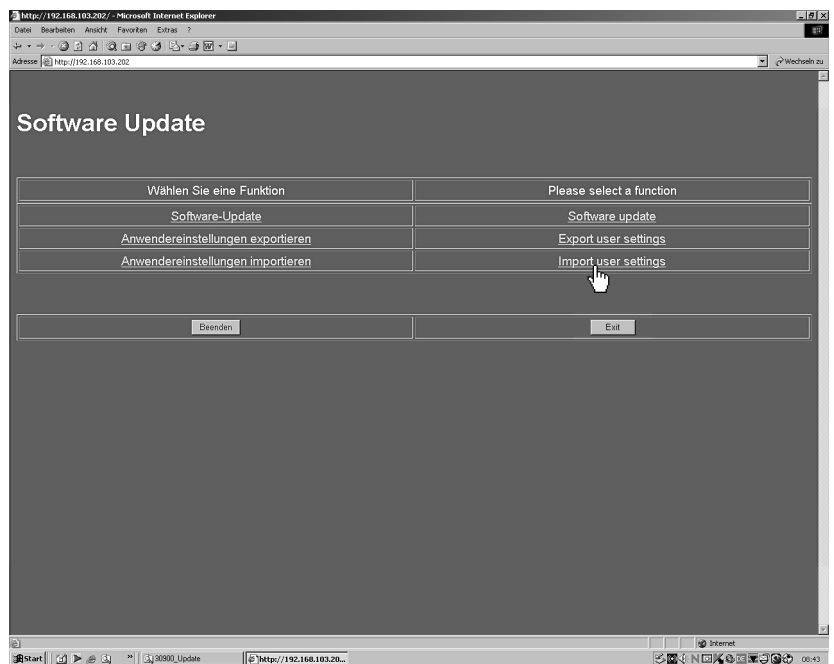

Fig. 5-18: Software Update Program menu in web browser

3. Please click the „Durchsuchen“ button (see Fig. 5-19) to browse for the user settings data file.

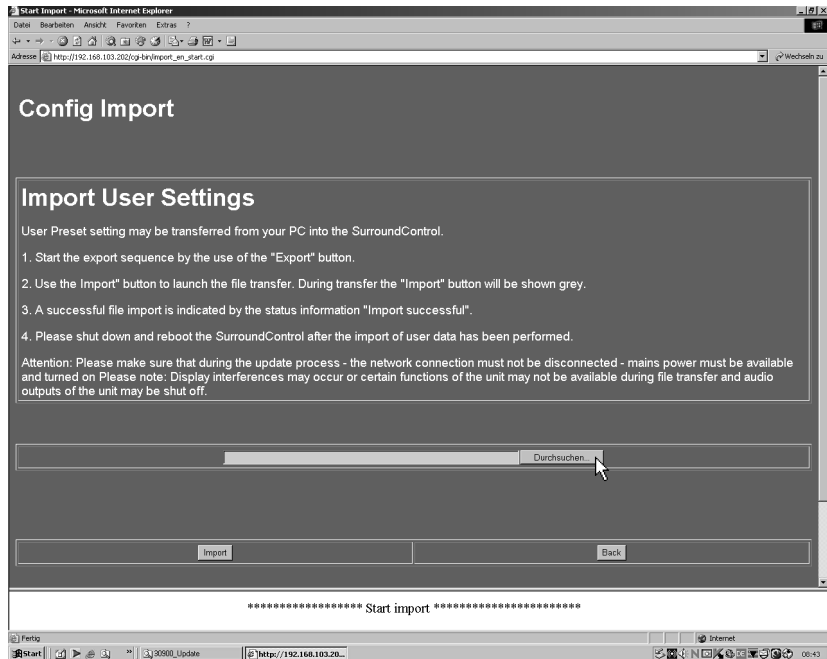

Fig. 5-19: Display of the Import menu page („Durchsuchen“)

4. Choose the folder (i. e.: C:\30900\_update) with the user settings data file and click the file config.tar.gz (see Fig. 5-20).

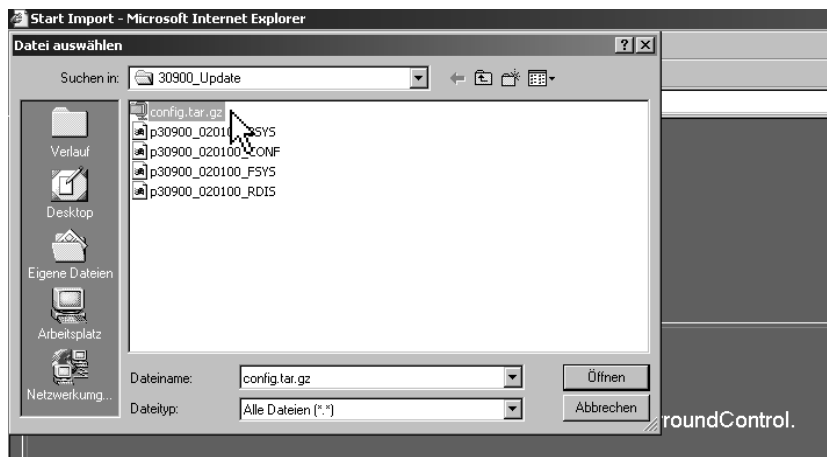

Fig. 5-20: The import file selection dialog box (config.tar.gz)

- A click to the Import button starts the data transfer to the SurroundControl 30900(-24) (see Fig. 5-21). If the Import button is not visible move the menu page upward by using the scrollbar on the right. **Please make sure that no interruption of the network access or supply power occurs during the download sequence.**

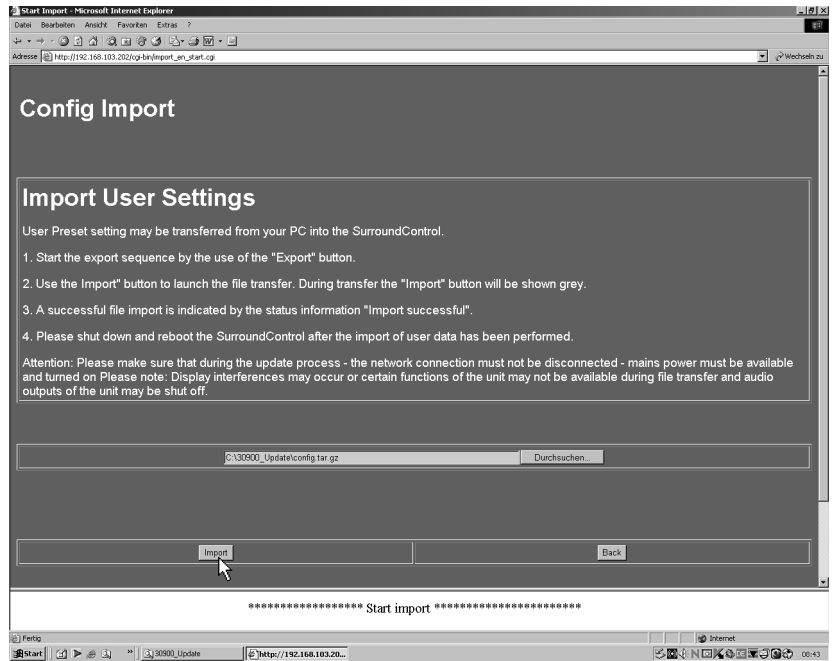

Fig. 5-21: Starting the import

- Create config file is displayed while the transfer is running (see Fig. 5-22).

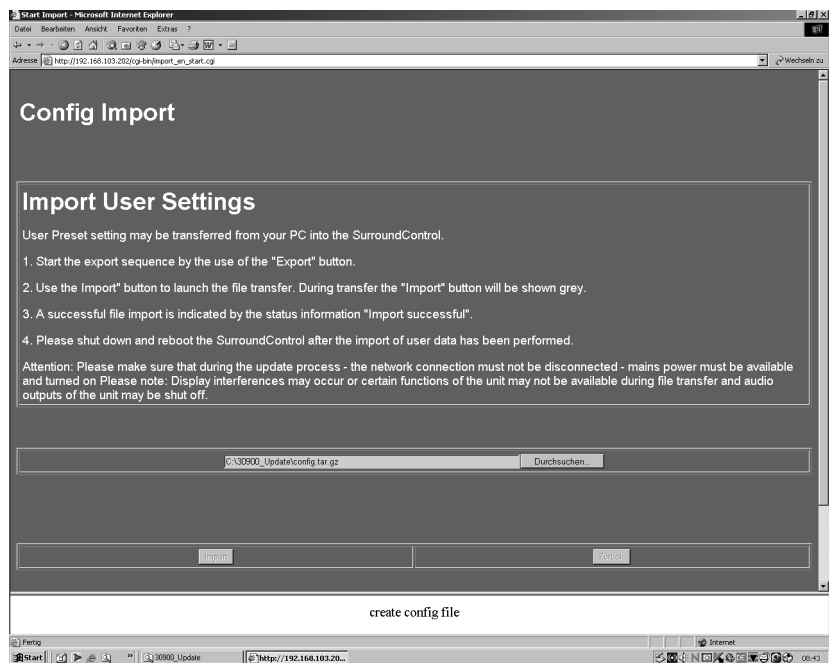

Fig. 5-22: The data transfer of the user settings is running

- When Import successful - PLEASE MAKE POWER OFF is displayed the Import process is finished (see Fig. 5-23). For activating the imported user settings the SurroundControl 30900(-24) has to be restarted.

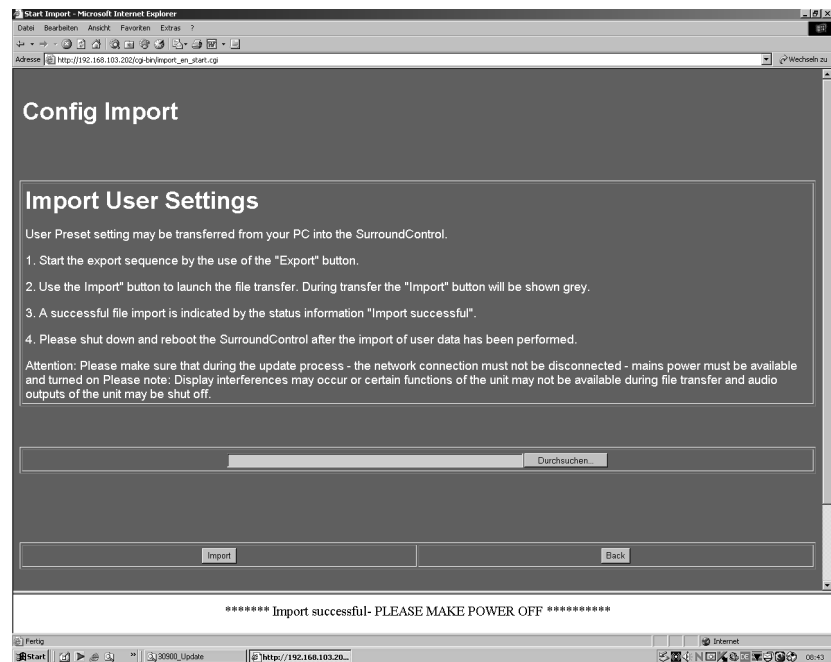

Fig. 5-23: End of the import of the user settings

- Click the Back button (see Fig. 5-23) to get back to the home page (see Fig. 5-18). There please click Finish to leave the software update program.
- Please wait approx. 5 sec. after shut down of the unit before you power it up again.
- When the SurroundControl 30900(-24) is rebooting the imported user settings will be configured and activated. Then it is ready to use.



# 6 Mechanical Layout

## 6.1 Dimensions

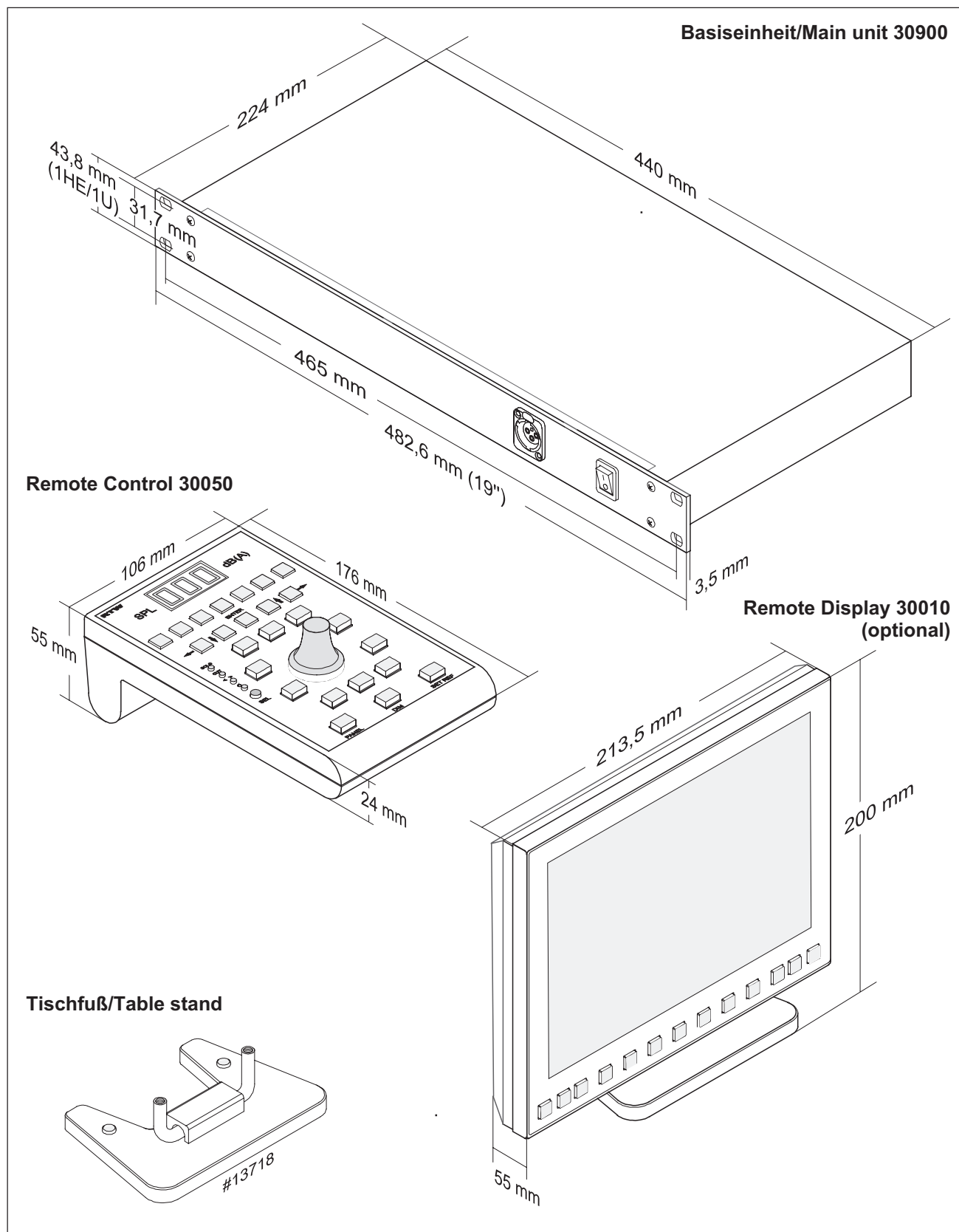

Fig. 6-1: Dimensions of the SurroundControl 30900(-24) system

## 6.2 Configuration

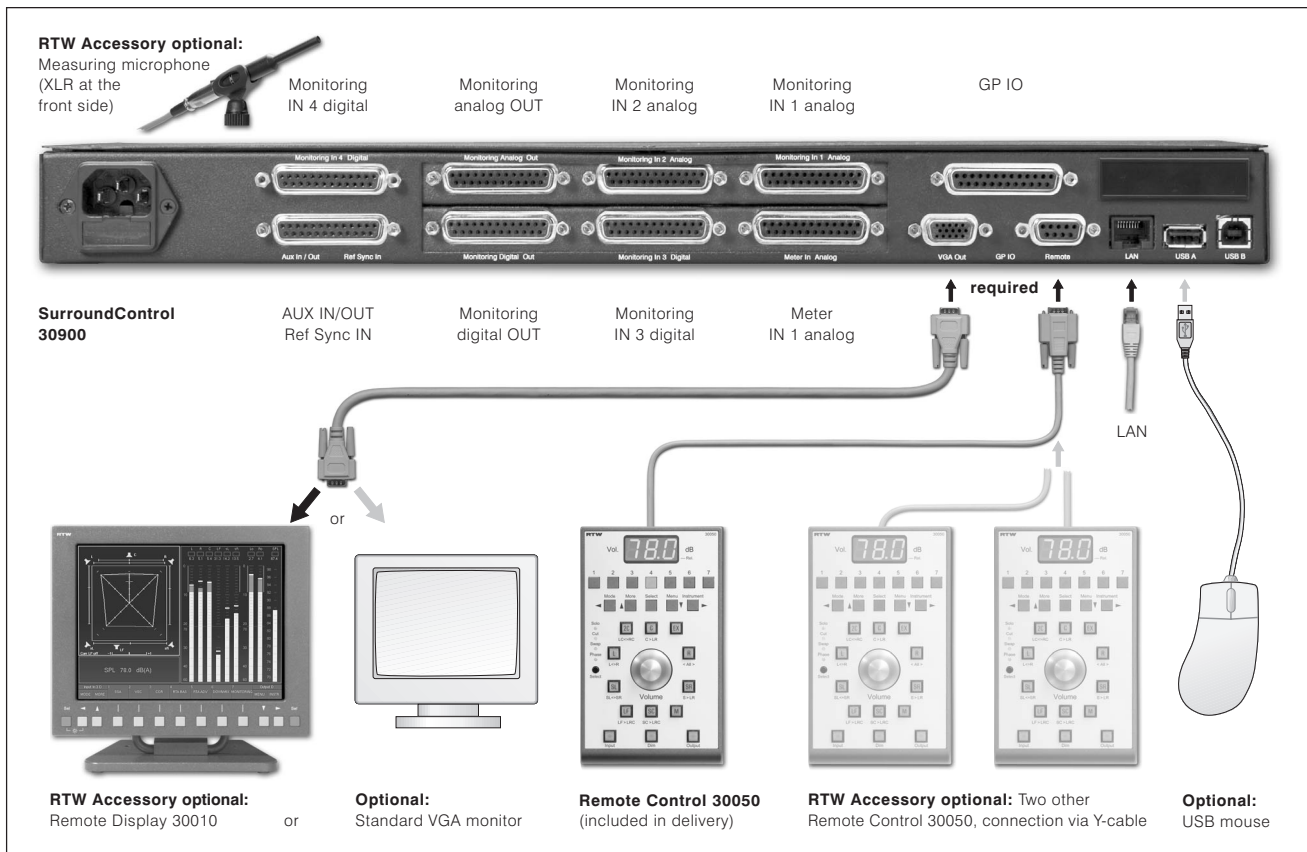

Fig. 6-2: Overview of the configuration of the SurroundControl 30900(-24) system

## 6.3 Accessories

The following accessories are available from RTW:

Description	Order No.
• Measuring microphone	<b>13720</b>
• Remote Display (VGA) TFT monitor with integrated function and control keys	<b>30010</b>
• Remote Control up to three can be connected via y cable	<b>30050</b>

# Appendix A: Specifications

## Functions

- multi format surround peakmeter (5.1, 6.1, 7.1)
- 2-channel peakmeter in 2 Channel Stereo mode
- selectable 2-channel peakmeter and SPL meter, analog and digital
- Surround sound analyzer
- 10-way multi phase meter display
- 1/3- and 1/6-octave spectrum analyzer
- 2- and 4-channel audio vector scope
- Dialnorm meter
- Downmix meter
- AES/EBU status monitor
- 8-channel monitoring controller
- Surround test signal generator
- SPL meter
- alarm functions

## Analog Inputs

- Metering: 8 analog inputs, Sub-D-F connector, 25-pin
- Monitoring/Metering: 2 x 8 analog inputs, one Sub-D-F connector each, 25-pin
  - Nominal input level: +6 dBu
  - Adjustment range: Level Offset via software:  $\pm 8$  dB
  - Maximum input level: +19 dBu (30900)  
+24 dBu (30900-24 **only**)
  - Impedance:  $> 10$  k $\Omega$ , electr. balanced
  - Frequency response: 20 Hz to 22 kHz,  $\pm 0.25$  dB @ 48 kHz
  - THD+N:  $< 105$  dB @ 48 kHz
  - Crosstalk:  $< 105$  dB (Frequency range 22 Hz to fs/2)
- Measuring microphone input: balanced, phantom power supply, XLR-F connector for measuring microphones with open circuit voltage of 15 mV/Pa @ 1 kHz

## Digital Inputs

- Monitoring/Metering: 2 x 4 AES/EBU inputs, 110  $\Omega$ , transformer balanced, Sub-D-F connector, 25-pin
- External clock signal: AES/EBU signal, transformer balanced, Sub-D-F connector, 25-pin
- Sampling rates: 44.1, 48, 96 kHz, synchronisation via digital input signal or Ref Sync input

## Analog Outputs

- Monitoring: 8 analog outputs, electronically balanced, Sub-D-F connector, 25-pin
  - Maximum nominal level: for 0 dB FS selectable:
    - EBU RP68 (+18 dBu),
    - ARD (+15 dBu);
    - SMPTE RP155 (+24 dBu) (30900-24 **only**)
    - User (+18 .. +24 dBu) (30900-24 **only**)

- Maximum level: +19 dBu (30900)  
+24 dBu (30900-24 **only**)
- Frequency range: 20 Hz to 22 kHz,  $\pm 0.25$  dB @ 48 kHz
  - THD+N: < 100 dB

### Digital Outputs

- Monitoring: 4 AES/EBU outputs, 110  $\Omega$ , transformer balanced, Sub-D-F connector, 25-pin
- Sampling rates: same as digital inputs or internal, 44.1, 48, 96 kHz

### Monitoring Controller

- Volume control: control range > 85 dB, mute, calibration in dB(A) possible
- Channel functions:
  - Solo,
  - Cut,
  - Phase,
  - Mono (Mono-to-Center or Mono-to-LR),
  - Side Swap,
  - Center-to-LR,
  - Rear-to-Front,
  - LF-to-Front,
  - DIM
- Channel level offset, delay: level:  $\pm 10$  dB,  
delay: 0 - 50 ms, respectively selectable for each channel
- Downmix matrix: 2-Channel mix of the monitoring surround signal and 2-channel mix derived from one of the digital inputs (2Ch-Direct-Out), mixing coefficients selectable for each channel

### Peakmeters, General

- Input sources: Metering input (analog) or selected monitoring input, switching analog/digital
- Surround peakmeter: 5.1, 6.1 or 7.1 surround, track layout selectable:
  - SMPTE-TV(ITU, SSF),
  - SMPTE-Film,
  - DTS,
  - Film
- 2-Channel peakmeter: for the defined stereo channel pair L and R
- additional 2-Ch. peakmeter: switchable, for external signals or internal generated  $L_0/R_0$  signals (2Ch-Downmix), L+R and L-R indication switchable
- SPL meter: switchable, indication of the total sound pressure level calculated from the individual channels
- Indicators:
  - peak level, -
  - RMS level (linear, A-, C-weighted),
  - peak hold,
  - numerical value of the peak hold level,
  - Digital Over

- Functions:
  - Gain (+20 dB, +40 dB acc. to standard),
  - Peak hold on,
  - RMS on,
  - Memory,
  - Reset,
  - Alarm (threshold over, silence)

### Analog Peakmeters

- Analog scales:
  - DIN,
  - DIN+10,
  - IEC 268 Type I (Nordic N9),
  - IEC 268-10A (Type IIa, Type IIb),
  - VU,
  - Zoom  $\pm 10$  dB,
  - Zoom  $\pm 1$  dB
  - SMPTE 24 dB – abs (30900-24 **only**)
  - SMPTE 20 dB – rel (30900-24 **only**)
  - NHK (30900-24 **only**)
- Integration time: according to standard or 300 ms, 20 ms, 10 ms, 1 ms, 0.1 ms
- Reference level (PML): according to standard:
  - +6 dBu (DIN, Nordic), +9 dBu (British) or selectable offset ( $\pm 8$  dB)
  - additionally for 30900-24:**
  - NHK: 0 dB @ system reference level
  - SMPTE 24 dB – abs: 0 dB @ 0 dBu
  - SMPTE 20 dB – rel: 0 dB @ +4 dBu

### Digital Peakmeters

- Word width: 24 bit
- Digital scales:
  - Digital 1 (0 dB FS to –60 dB FS absolute)
  - Digital 2 (0 dB FS to –20 dB FS absolute)
  - Digital 3 (18 dB to 0 dB relative, 0 dB @ –18 dB FS)
  - Digital 4 (18 dB to –18 dB relative, 0 dB @ –18 dB FS)
  - Digital 5 (20 dB to –40 dB relative, 0 dB @ –20 dB FS)
  - ARD +9 dB to –60 dB (0 dB @ –9 dB FS)
  - Q-DIN5,
  - Q-DIN10,
  - Zoom  $\pm 10$  dB
  - Zoom  $\pm 1$  dB (0 dB @ headroom setting)
  - Q-Nordic
- Headroom: selectable in 1 dB steps from -5 dB FS to -20 dB FS
- Integration time (Attack): sample or 20 ms, 10 ms, 1 ms, 0.1 ms
- Additional Gain: 40 dB
- High-pass filter: Off, 5 Hz, 10 Hz, 20 Hz
- Peak Hold indicator: integration time sample or same as level indication

- Over indicator (Clip):
  - Operating threshold: FS, FS-1LSB, FS-2LSB, -0.1 dB FS, -0.5 dB FS, -1 dB FS, -2 dB FS, -3 dB FS
  - Attack time: 1 to 15 samples
  - Word width: 16 to 24 bit selectable

### SPL Meter

- Measuring range: Low: 50 – 78 dB(SPL)  
Mid: 70 – 98 dB(SPL)  
High: 90 – 118 dB(SPL)
- Input sources: internal (mix of the surround channels), external (measuring input)
- Weighting: linear, A, C
- Integration time: F (125 ms), S (1 s)

### Surround Sound Analyzer

(available in surround mode only)

- Indicators:
  - graphics display indicating the single channel and total program loudness (Total Volume Indicator)
  - correlation of adjacent channels
  - position and width of phantom sound sources
- Measuring method: A-weighted RMS level (SPL) referring to the reference monitoring sound pressure level

### Multi-fold Phase Meter

- Surround mode
  - Display mode: for each channel pair in 5.1 format
  - Filter: low pass filter switchable (300 Hz)
- 2 Channel Stereo mode
  - Display mode: for the defined stereo channel pair L and R and the external channels  $L_{ext}$  and  $R_{ext}$

### Audio Vector Scope

- Surround mode
  - Modes:
    - 2-channel
    - 4-channel (fixed: L-R upper part, LS-RS lower part)
  - Input sources: in 2-channel mode selectable: L-R, LS-RS, L-LS, R-RS, L-C, C-R,  $L_{ext}$ - $R_{ext}$ ,  $L_0$ - $R_0$
  - Auto Gain: fast/slow
  - Functions:
    - Indication: Fast - Slow
    - Display: Normal - M/S
  - Phase meter: in 2- and 4-channel mode for displayed channel pairs
- 2 Channel Stereo mode
  - Input sources: L-R,  $L_{ext}$ - $R_{ext}$
  - Auto Gain: fast/slow
  - Functions:
    - indication: Fast - Slow
    - display: Normal - M/S
  - Phase meter: for the defined stereo channel pair L and R and the external channels  $L_{ext}$  and  $R_{ext}$

### **Spectrum Analyzer (RTA)**

- Input sources: Selectable:  
all channels without LF, Rear, L/R, single channels, measuring input
- Frequency range:
  - Norm: 20 Hz to 20 kHz,  
add-on band > 20 kHz to fs/2
  - LF: 5 Hz to 5 kHz
- Number of bands:
  - 1/3-octave: 31 bands, Filter acc. to IEC 225 class 2,
  - 1/6-octave: 61 bands
- Measuring range: 45 dB
- Resolution: 1, 2, 3 dB
- Functions:
  - Input select
  - Peak hold on
  - Display hold
  - Cursor readout
  - A-, C-weighting
  - Integration time
  - Set reference
  - Scaling
  - Frequency range
- Integration time: I (impulse), F, S, peak (10 ms)

### **Downmix Meter**

(available in surround mode only)

- Input sources: internal generated downmix signals or external 2-channel signals
- Indicators:
  - peak level
  - peak hold
  - RMS
  - audio vector scope
  - phase meterfor scales and standards see analog/digital peakmeter

### **Test Signal Generator**

- Signals:
  - pink noise: 20 Hz to 20 kHz  
200 Hz to 20 kHz
  - octave-band noise
  - sine wave
- Level:
  - 3 selectable levels:  
-9, -18, -20 dB FS RMS
  - variable in 1 dB steps:  
from 0 dB FS to -99 dB FS
- Outputs: analog or digital, signal is switched to the active channel or to all channels

### **AES/EBU Status Monitor**

- Indicators:
  - channel data are displayed as plain text, hex or binary
  - channel selectable
  - audio bit activity
  - hardware status

## System

- Remote control: RS-422, for connecting up to three units of Remote Control 30050.  
Sub-D-F connector, 9-pin
- GP IO (parallel):
  - 16 inputs, functions internal adjustable
  - 8 outputs for indication of alert events (threshold over, silence, Digital Over),  
Sub-D-F connector, 25-pin
  - GP IO inputs: active low, pulse or momentary function  
internal adjustable
  - GP IO outputs: internal adjustable active high or low,  
(0.1 s, 0.5 s, 1 s, 2 s, manual)
- USB: for connecting a computer mouse,  
USB 1.1,  $I_{\max}$  0.5 A
- Network: software update,  
other functions on request
- Video: VGA, 640 x 480, 256 colours, 60 Hz, for  
connecting a CRT or TFT monitor or the  
optional 8.4-inch Remote Display 30010

## General

- Operating temperature range: 0° to +45° C

## SurroundControl 30900/30900-24

- Power requirements: 85 to 264 V AC, 60 VA
- Dimensions: 19-inch/1U rack mount housing,  
depth 225 mm
- Weight: 3,7 kg
- Items supplied:
  - main unit 30900/30900-24 (processor)
  - Remote Control 30050
  - mains supply cable
  - operating manual

## Remote Control 30050

- Dimensions: 106 x 55 x 176 mm (W x H x D)
- Weight: 600 g with cable
- Type of connection: fixed cable, 5 m,  
with Sub-D-m connector, 9-pin
- Max. cable length: 25 m

## Optional accessories for 30900

- Remote Display 30010
- additional Remote Control 30050
- snake cable 1186 (8 x XLR-f connector  
to Sub-D-m connector, 25-pin, length 4 m)
- snake cable 1163 (8 x XLR-m connector  
to Sub-D-m connector, 25-pin, length 4 m)

Subject to changes without prior notice



## Appendix B: Declaration of Conformity

### EC Declaration of Conformity Directive 89/336/EEC and Directive 73/23/EEC

We,

**RTW GmbH & Co.KG**  
Elbeallee 19 · 50765 Köln · Germany

declare under sole responsibility that the product:

### **RTW SurroundControl 30900/30900-24 (inclusive Remote Control 30050)**

meet the intend of the Directive 89/336/EEC and Directive 73/23/EEC. Compliance was demonstrated to the following specifications as listed in the official Journal of the European Communities:

#### **EMC**

#### **89/336/EEC**

EN 50103-1 Emissions: EN 55022 Class B, radiated  
EN 55022 Class B, conducted

EN 50082-1 Immunity: EN 61000-4-2  
EN 61000-4-3  
EN 61000-4-4  
EN 61000-4-5  
EN 61000-4-6  
EN 61000-4-11

#### **Safety**

#### **73/23/EEC**

EN 60950 (1992 + A1/1993)

Tested and documented by the following companies:

**SERCO GmbH**, Bonn, accredited EMC laboratory  
**RTW GmbH & Co.KG**, Köln

Date and signature of the responsible person:

2004-11-18





# Appendix C: Licenses

## Information on the licenses that apply to the software supplied with the product

In addition to the hardware the RTW SurroundControl 30900(-24) product also includes a software package for which a variety of licenses apply:

- A. Software produced by RTW GmbH & Co.KG, which may only be used for the proper operation of the product as described in the documentation (application, DSP programs, boot loader). This software is the property of RTW GmbH & Co.KG and is protected by German and international copyrights.
- B. Third-party software (the Qt library from Trolltech AS), which is linked with the software described under A, and which also may only be used for the proper operation of the product. Qt® is a registered trademark of the Norwegian company Trolltech AS.
- C. Open source software, released under the GPL (General Public License) of the Free Software Foundation (FSF):
  - 1. Linux Kernel 2.4.19
  - 2. TinyLogin 1.4
  - 3. GDB 6.0
  - 4. s1811 USB Host Driver (by Cypress)
  - 5. Apache web server 1.3.6
  - 6. Busy Box 1.10

The original English version of the GPL is included in appendix D. Only the original English version is legally binding, however.

Some changes have been made to the open-source software packages 1 - 5 listed above. On request you can have the source code of the altered software sent to you within three years of purchasing the product.

Cologne, November 2006



Also see:

[www.gnu.org/copyleft/gpl.html](http://www.gnu.org/copyleft/gpl.html)

# Appendix D: GNU GENERAL PUBLIC LICENSE

Version 2, June 1991

Copyright (C) 1989, 1991 Free Software Foundation, Inc.  
59 Temple Place, Suite 330, Boston, MA 02111-1307 USA

Everyone is permitted to copy and distribute verbatim copies of this license document, but changing it is not allowed.

## **Preamble**

The licenses for most software are designed to take away your freedom to share and change it. By contrast, the GNU General Public License is intended to guarantee your freedom to share and change free software--to make sure the software is free for all its users. This General Public License applies to most of the Free Software Foundation's software and to any other program whose authors commit to using it. (Some other Free Software Foundation software is covered by the GNU Library General Public License instead.) You can apply it to your programs, too.

When we speak of free software, we are referring to freedom, not price. Our General Public Licenses are designed to make sure that you have the freedom to distribute copies of free software (and charge for this service if you wish), that you receive source code or can get it if you want it, that you can change the software or use pieces of it in new free programs; and that you know you can do these things.

To protect your rights, we need to make restrictions that forbid anyone to deny you these rights or to ask you to surrender the rights. These restrictions translate to certain responsibilities for you if you distribute copies of the software, or if you modify it.

For example, if you distribute copies of such a program, whether gratis or for a fee, you must give the recipients all the rights that you have. You must make sure that they, too, receive or can get the source code. And you must show them these terms so they know their rights.

We protect your rights with two steps: (1) copyright the software, and (2) offer you this license which gives you legal permission to copy, distribute and/or modify the software.

Also, for each author's protection and ours, we want to make certain that everyone understands that there is no warranty for this free software. If the software is modified by someone else and passed on, we want its recipients to know that what they have is not the original, so that any problems introduced by others will not reflect on the original authors' reputations.

Finally, any free program is threatened constantly by software patents. We wish to avoid the danger that redistributors of a free program will individually obtain patent licenses, in effect making the program proprietary. To prevent this, we have made it clear that any patent must be licensed for everyone's free use or not licensed at all.

The precise terms and conditions for copying, distribution and modification follow.

## **TERMS AND CONDITIONS FOR COPYING, DISTRIBUTION AND MODIFICATION**

0. This License applies to any program or other work which contains a notice placed by the copyright holder saying it may be distributed under the terms of this General Public License. The "Program", below, refers to any such program or work, and a "work based on the Program" means either the Program or any derivative work under copyright law: that is to say, a work containing the Program or a portion of

it, either verbatim or with modifications and/or translated into another language. (Hereinafter, translation is included without limitation in the term "modification".) Each licensee is addressed as "you".

Activities other than copying, distribution and modification are not covered by this License; they are outside its scope. The act of running the Program is not restricted, and the output from the Program is covered only if its contents constitute a work based on the Program (independent of having been made by running the Program). Whether that is true depends on what the Program does.

1. You may copy and distribute verbatim copies of the Program's source code as you receive it, in any medium, provided that you conspicuously and appropriately publish on each copy an appropriate copyright notice and disclaimer of warranty; keep intact all the notices that refer to this License and to the absence of any warranty; and give any other recipients of the Program a copy of this License along with the Program.

You may charge a fee for the physical act of transferring a copy, and you may at your option offer warranty protection in exchange for a fee.

2. You may modify your copy or copies of the Program or any portion of it, thus forming a work based on the Program, and copy and distribute such modifications or work under the terms of Section 1 above, provided that you also meet all of these conditions:

- a) You must cause the modified files to carry prominent notices stating that you changed the files and the date of any change.
- b) You must cause any work that you distribute or publish, that in whole or in part contains or is derived from the Program or any part thereof, to be licensed as a whole at no charge to all third parties under the terms of this License.
- c) If the modified program normally reads commands interactively when run, you must cause it, when started running for such interactive use in the most ordinary way, to print or display an announcement including an appropriate copyright notice and a notice that there is no warranty (or else, saying that you provide a warranty) and that users may redistribute the program under these conditions, and telling the user how to view a copy of this License. (Exception: if the Program itself is interactive but does not normally print such an announcement, your work based on the Program is not required to print an announcement.)

These requirements apply to the modified work as a whole. If identifiable sections of that work are not derived from the Program, and can be reasonably considered independent and separate works in themselves, then this License, and its terms, do not apply to those sections when you distribute them as separate works. But when you distribute the same sections as part of a whole which is a work based on the Program, the distribution of the whole must be on the terms of this License, whose permissions for other licensees extend to the entire whole, and thus to each and every part regardless of who wrote it.

Thus, it is not the intent of this section to claim rights or contest your rights to work written entirely by you; rather, the intent is to exercise the right to control the distribution of derivative or collective works based on the Program.

In addition, mere aggregation of another work not based on the Program with the Program (or with a work based on the Program) on a volume of a storage or distribution medium does not bring the other work under the scope of this License.

3. You may copy and distribute the Program (or a work based on it, under Section 2) in object code or executable form under the terms of Sections 1 and 2 above provided that you also do one of the following:

- a) Accompany it with the complete corresponding machine-readable source code, which must be distributed under the terms of Sections 1 and 2 above on a medium customarily used for software interchange; or,
- b) Accompany it with a written offer, valid for at least three years, to give any third party, for a charge no more than your cost of physically performing source distribution, a complete machine-readable copy of the corresponding source code, to be distributed under the terms of Sections 1 and 2 above on a medium customarily used for software interchange; or,
- c) Accompany it with the information you received as to the offer to distribute corresponding source code. (This alternative is allowed only for noncommercial distribution and only if you received the program in object code or executable form with such an offer, in accord with Subsection b above.)

The source code for a work means the preferred form of the work for making modifications to it. For an executable work, complete source code means all the source code for all modules it contains, plus any associated interface definition files, plus the scripts used to control compilation and installation of the executable. However, as a special exception, the source code distributed need not include anything that is normally distributed (in either source or binary form) with the major components (compiler, kernel, and so on) of the operating system on which the executable runs, unless that component itself accompanies the executable. If distribution of executable or object code is made by offering access to copy from a designated place, then offering equivalent access to copy the source code from the same place counts as distribution of the source code, even though third parties are not compelled to copy the source along with the object code.

- 4. You may not copy, modify, sublicense, or distribute the Program except as expressly provided under this License. Any attempt otherwise to copy, modify, sublicense or distribute the Program is void, and will automatically terminate your rights under this License. However, parties who have received copies, or rights, from you under this License will not have their licenses terminated so long as such parties remain in full compliance.
- 5. You are not required to accept this License, since you have not signed it. However, nothing else grants you permission to modify or distribute the Program or its derivative works. These actions are prohibited by law if you do not accept this License. Therefore, by modifying or distributing the Program (or any work based on the Program), you indicate your acceptance of this License to do so, and all its terms and conditions for copying, distributing or modifying the Program or works based on it.
- 6. Each time you redistribute the Program (or any work based on the Program), the recipient automatically receives a license from the original licensor to copy, distribute or modify the Program subject to these terms and conditions. You may not impose any further restrictions on the recipients' exercise of the rights granted herein. You are not responsible for enforcing compliance by third parties to this License.
- 7. If, as a consequence of a court judgment or allegation of patent infringement or for any other reason (not limited to patent issues), conditions are imposed on you (whether by court order, agreement or otherwise) that contradict the conditions of this License, they do not excuse you from the conditions of this License. If you cannot distribute so as to satisfy simultaneously your obligations under this License and any other pertinent obligations, then as a consequence you may not distribute the Program at all. For example, if a patent license would not permit royalty-free redistribution of the Program by all those who receive copies directly or indirectly through you, then the only way you could satisfy both it and this License would be to refrain entirely from distribution of the Program.  
If any portion of this section is held invalid or unenforceable under any particular circumstance, the balance of the section is intended to apply and the section as a whole is intended to apply in other circumstances.

It is not the purpose of this section to induce you to infringe any patents or other property right claims or to contest validity of any such claims; this section has the sole purpose of protecting the integrity of the free software distribution system, which is implemented by public license practices. Many people have made generous contributions to the wide range of software distributed through that system in reliance on consistent application of that system; it is up to the author/donor to decide if he or she is willing to distribute software through any other system and a licensee cannot impose that choice.

This section is intended to make thoroughly clear what is believed to be a consequence of the rest of this License.

8. If the distribution and/or use of the Program is restricted in certain countries either by patents or by copyrighted interfaces, the original copyright holder who places the Program under this License may add an explicit geographical distribution limitation excluding those countries, so that distribution is permitted only in or among countries not thus excluded. In such case, this License incorporates the limitation as if written in the body of this License.

9. The Free Software Foundation may publish revised and/or new versions of the General Public License from time to time. Such new versions will be similar in spirit to the present version, but may differ in detail to address new problems or concerns.

Each version is given a distinguishing version number. If the Program specifies a version number of this License which applies to it and "any later version", you have the option of following the terms and conditions either of that version or of any later version published by the Free Software Foundation. If the Program does not specify a version number of this License, you may choose any version ever published by the Free Software Foundation.

10. If you wish to incorporate parts of the Program into other free programs whose distribution conditions are different, write to the author to ask for permission. For software which is copyrighted by the Free Software Foundation, write to the Free Software Foundation; we sometimes make exceptions for this. Our decision will be guided by the two goals of preserving the free status of all derivatives of our free software and of promoting the sharing and reuse of software generally.

#### NO WARRANTY

11. BECAUSE THE PROGRAM IS LICENSED FREE OF CHARGE, THERE IS NO WARRANTY FOR THE PROGRAM, TO THE EXTENT PERMITTED BY APPLICABLE LAW. EXCEPT WHEN OTHERWISE STATED IN WRITING THE COPYRIGHT HOLDERS AND/OR OTHER PARTIES PROVIDE THE PROGRAM "AS IS" WITHOUT WARRANTY OF ANY KIND, EITHER EXPRESSED OR IMPLIED, INCLUDING, BUT NOT LIMITED TO, THE IMPLIED WARRANTIES OF MERCHANTABILITY AND FITNESS FOR A PARTICULAR PURPOSE. THE ENTIRE RISK AS TO THE QUALITY AND PERFORMANCE OF THE PROGRAM IS WITH YOU. SHOULD THE PROGRAM PROVE DEFECTIVE, YOU ASSUME THE COST OF ALL NECESSARY SERVICING, REPAIR OR CORRECTION.

12. IN NO EVENT UNLESS REQUIRED BY APPLICABLE LAW OR AGREED TO IN WRITING WILL ANY COPYRIGHT HOLDER, OR ANY OTHER PARTY WHO MAY MODIFY AND/OR REDISTRIBUTE THE PROGRAM AS PERMITTED ABOVE, BE LIABLE TO YOU FOR DAMAGES, INCLUDING ANY GENERAL, SPECIAL, INCIDENTAL OR CONSEQUENTIAL DAMAGES ARISING OUT OF THE USE OR INABILITY TO USE THE PROGRAM (INCLUDING BUT NOT LIMITED TO LOSS OF DATA OR DATA BEING RENDERED INACCURATE OR LOSSES SUSTAINED BY YOU OR THIRD PARTIES OR A FAILURE OF THE PROGRAM TO OPERATE WITH ANY OTHER PROGRAMS), EVEN IF SUCH HOLDER OR OTHER PARTY HAS BEEN ADVISED OF THE POSSIBILITY OF SUCH DAMAGES.

#### **END OF TERMS AND CONDITIONS**



## How to Apply These Terms to Your New Programs

If you develop a new program, and you want it to be of the greatest possible use to the public, the best way to achieve this is to make it free software which everyone can redistribute and change under these terms.

To do so, attach the following notices to the program. It is safest to attach them to the start of each source file to most effectively convey the exclusion of warranty; and each file should have at least the "copyright" line and a pointer to where the full notice is found.

<one line to give the program's name and an idea of what it does.>

Copyright (C) <year> <name of author>

This program is free software; you can redistribute it and/or modify it under the terms of the GNU General Public License as published by the Free Software Foundation; either version 2 of the License, or (at your option) any later version.

This program is distributed in the hope that it will be useful, but WITHOUT ANY WARRANTY; without even the implied warranty of MERCHANTABILITY or FITNESS FOR A PARTICULAR PURPOSE. See the GNU General Public License for more details.

You should have received a copy of the GNU General Public License along with this program; if not, write to the Free Software Foundation, Inc., 59 Temple Place - Suite 330, Boston, MA 02111-1307, USA.

Also add information on how to contact you by electronic and paper mail.

If the program is interactive, make it output a short notice like this when it starts in an interactive mode:

Gnomovision version 69, Copyright (C) year name of author Gnomovision comes with ABSOLUTELY NO WARRANTY; for details type `show w'. This is free software, and you are welcome to redistribute it under certain conditions; type `show c' for details.

The hypothetical commands `show w' and `show c' should show the appropriate parts of the General Public License. Of course, the commands you use may be called something other than `show w' and `show c'; they could even be mouse-clicks or menu items--whatever suits your program.

You should also get your employer (if you work as a programmer) or your school, if any, to sign a "copyright disclaimer" for the program, if necessary. Here is a sample; alter the names:

Yoyodyne, Inc., hereby disclaims all copyright interest in the program `Gnomovision' (which makes passes at compilers) written by James Hacker.

<signature of Ty Coon>, 1 April 1989

Ty Coon, President of Vice

This General Public License does not permit incorporating your program into proprietary programs. If your program is a subroutine library, you may consider it more useful to permit linking proprietary applications with the library. If this is what you want to do, use the GNU Lesser General Public License instead of this License.

