

# Data Sheet TM3-Primus

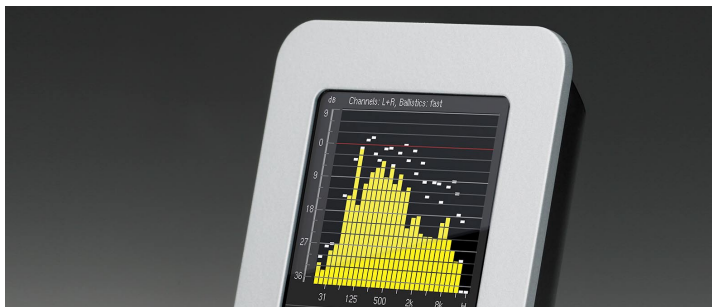

# TM3-Primus



**Optimized touch screen layout • analog, digital, USB audio inputs • digital output • Smart software • Loudness according to all relevant standards • LRA • PPM/True Peak • Chart • RTA • Audio Vectorscope • Monitoring • Moving Coil • Correlator**

RTW's TM3-Primus is a highly compact and innovative, easy-to-use product, giving music, voice, and multimedia producers everything they need for loudness and audio metering, including frequently used standard instruments and parameters in a high quality unit to meet the demands of a wide variety of applications. Beside the use as a standalone desktop unit including analog and digital audio interfaces, as well as USB audio, TM3-Primus also provides an innovative USB hybrid mode. Metering will be performed right from the DAW via RTW USB Connect plug-in without the need for additional wiring or extensive

signal routing. TM3-Primus will process and visualize the information simultaneously to monitoring the audio signal via DAW's audio interface. The graphical user interface used in TM3-Primus units is controlled simply by using your finger. Instruments can be selected and will be combined for an optimized reading. All commonly used parameters are set, just a few need to be adjusted by the user to meet individual requirements.

Start your measurement. TM3-Primus.

# Hardware

## TM3-Primus

- Compact unit with full feature set for multifunctional audio measurements (analog, digital, USB audio)
- Table-top unit with display and external USB mains adapter
- 4.3" capacitive touch screen (272 x 480 pixel)
- Optimized screen layout with selectable instruments
- Analog 2-channel stereo input via unbal. RCA, adjustable from -22 dBu (61 mV) to +24 dBu (12.28 V)
- Digital 2-channel stereo in- and output via S/PDIF (RCA)
- Micro-USB connector for digital audio inputs (stereo, 5.1) and USB power supply (USB mains adapter or PC)
- Loudness metering acc. to EBU R128, ITU-R BS.1770-4/1771-1, ATSC A/85, ARIB, OP-59, AGCOM, or CALM Act
- Summing loudness bargraph (M, S, I selectable)
- Numerical display (M, S, I, LRA, TPmax values)
- Loudness measurement control via onscreen keys
- Loudness Range (LRA) instrument with MagicLRA mode
- Loudness Chart instrument for displaying and analyzing the course of a loudness measurement over time
- PPM & True Peak measurement with standard scales
- Moving Coil instruments (PPM, VU, BBC mode)
- Real Time Analyzer (RTA) displaying the spectral distribution of an audio signal
- Audio Vectorscope (Lissajous display)
- Correlator instrument displaying the phase relationship between the two channels of a stereo signal
- Monitoring controller with onscreen level fader (downmix to S/PDIF out connector)
- USB hybrid function: Simultaneous monitoring and metering, and additional remote control of Start/Stop/Reset function with RTW USB Connect software



## TM3-Pri-2U

- 2U panel-mount unit with display, external USB mains adapter, and the same functionality as TM3-Primus

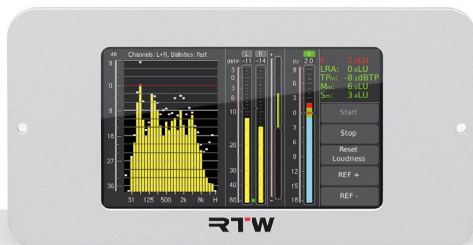

# Software

---

## Smart Software Package

With the integrated Smart software package, TM3-Primus is fully equipped. It provides a wide range of RTW's approved loudness and audio metering tools to meet the demands of a wide variety of applications. Beside the signal processing and the control functions this software includes the following instruments:

---

### TP/PPM Bargraph

PPM instrument displaying Peakmeter or TruePeak Meter bargraphs with analog or digital scales and numerical display.

### MC - Moving Coil

Moving Coil instrument for the display of needle instruments for 2-channel Stereo with PPM display, VU display, and combined PPM and Loudness display (BBC mode).

---

### Loudness Bar

Loudness Sum instrument for displaying the summed loudness values M, S, or I of a loudness measurement acc. to EBU R128, ITU BS.1770-4/1771-1, ARIB, ATSC A/85, OP-59, AGCOM, CALM Act on a bargraph display.

### Numeric Instrument

Loudness Num instrument for the numerical display of relevant values of a Loudness measurement: M, S, I, LRA, TPmax.

---

### Magic LRA

Loudness Range instrument in MagicLRA mode for a graphical representation of loudness variances.

### Chart

Loudness Chart instrument for displaying and analyzing the course over time of a loudness measurement directly on the display.

---

### VSC - Vectorscope

2-ch. Audio Vectorscope for displaying the phase relationship between the channels of a channel pair (Lissajous display).

### RTA

Real Time Spectrum Analyzer instrument for displaying the spectral content of the input channels using 31 filter bands. Highpass filter for High Band (>20 kHz).

---

### Monitoring

The Monitoring instrument provides a monitoring control function which enables monitoring of displayed audio signals and downmix of USB Surround to S/PDIF Out.

### Correlator

Stereo Correlator instrument for displaying the phase relationship between the two channels of a stereo signal and thus its mono compatibility.

---

### Keyboard

Selectable on-screen keys with defined functions for control of loudness measurement in multiple instruments.

---



## Software (continued)

---

### Optional Software

Optional software can be used to expand the fields of application for TM3-Primus.

---

#### RTW USB Connect (SW50300)

Available free of charge on our web site, the RTW USB Connect software enables a direct connection between a TM3-Primus and a DAW environment as a plug-in. It offers the remote control within the DAW for start/stop/reset or RTA reference to the TM3-Primus. With this software it is no longer necessary to define the TM3-Primus as output device (USB hybrid function). RTW USB connect can also be used as a stand-alone remote control for start/stop/reset or RTA reference to the TM3-Primus.

- Monitoring and metering at the same time.
- Plug-in operation for a direct connection between DAW and TM3-Primus via USB Connect.
- Direct access of Stereo or 5.1 audio signals from the DAW without dropping the audio interface.
- No need to define TM3-Primus as standard audio output device in the computer system.
- Remote control of start/stop/reset functions or RTA reference settings (MIDI controls) of the directly connected TM3-Primus via plug-in.
- Stand-alone operation for monitoring and metering of audio signals coming from media players or internet at the same time, and for remote control of start/stop/reset functions or RTW reference settings of TM3-Primus units.
- Sampling rates up to 96 kHz



# Dimensions

## TM3-Primus Table-top Unit

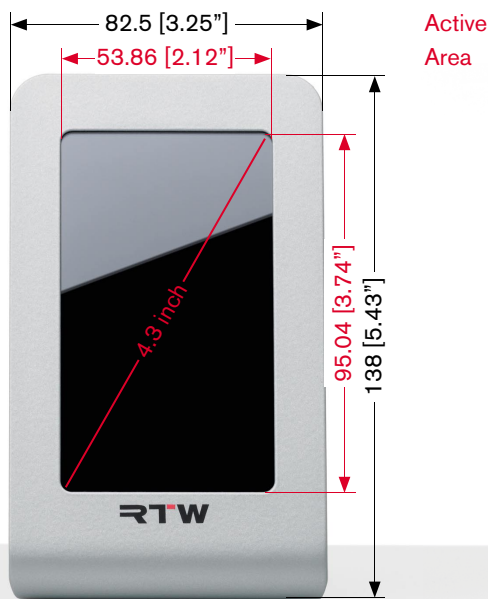

1 | Front view



2 | Side view



## Dimensions (continued)

### TM3-Pri-2U Panel-mount Unit

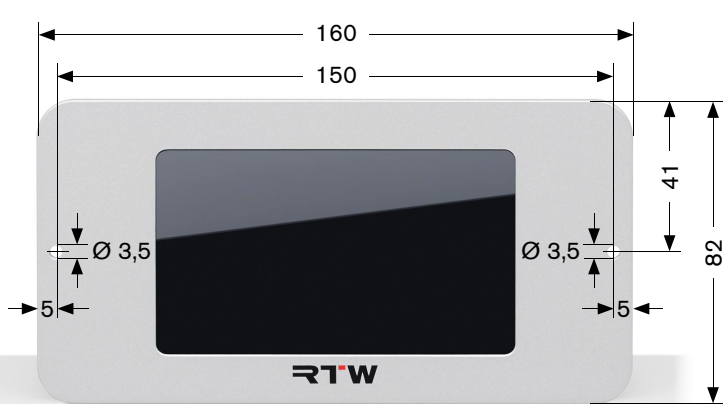

1 | Front view

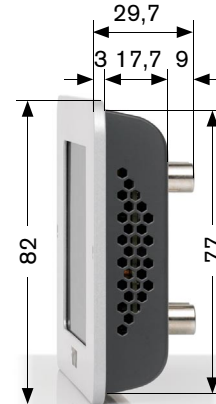

2 | Side view



3 | Rear view

Dimensions in mm [inch]  
Common tolerance:  $\pm 0,5$  mm [ $\pm 0.02$ "]

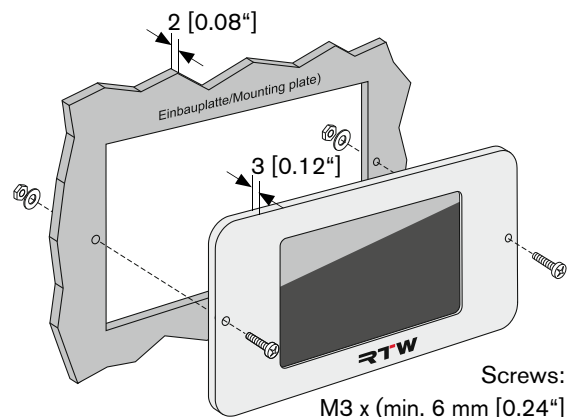

Screws:  
M3 x (min. 6 mm [0.24 inches]  
+ thickness of mounting plate)

5 | Diagram of mounting

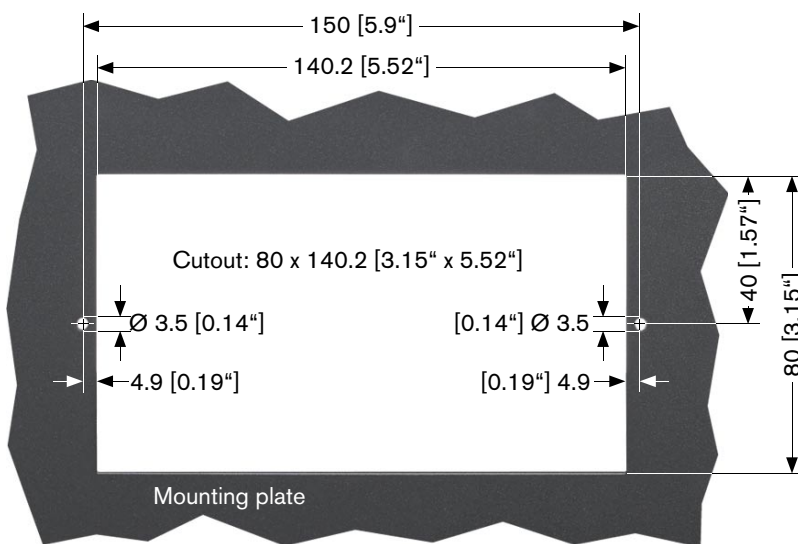

4 | Cutout of mounting plate



For adequate ventilation of the device after mounting, the mounting plate should have a maximum thickness of 2 mm [0.08 inches]

# Connection

**⚠ ATTENTION!** - TM3-Primus and TM3-Pri-2U can be operated either via connection directly from a computer or via mains adapter. For this, TM3-Primus and TM3-Pri-2U require appropriate USB mains adapters and USB connection cables. RTW recommends the use of the approved USB cables and the approved wide voltage USB power supplies included in the TM3-Primus and TM3-Pri-2U packages.

Potentiometers for adjustment of the analog input sensitivity for 0 dB reading (61 mV to 12.28 V)



**NOTE** – Do not disadjust, if not absolutely necessary. The unit has been calibrated at RTW and offers software calibration for analog 0 dB adjustment. **Please read chapter “Calibration” in the manual before performing adjustment changes!**

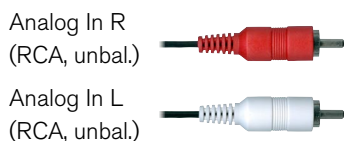

Shield/Chassis (Pin Assignment RCA connectors)

Signal



USB 2.0 Micro-B for:

- Power supply
- Audio input (if connected to a computer, a special Primus USB driver is required, see Specifications)

or:

- Power supply only (if USB mains adapter is used)



**Signal lines with RCA connector (3 m maximum) shall have a ferrite core at the end being connected to TM3-Primus and TM3-Pri-2U.**

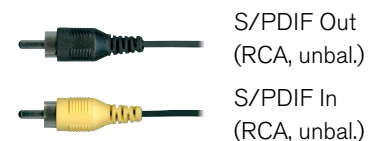

The S/PDIF input is permanently terminated with 75 Ω

The image shows the connectors of TM3-Primus as an example. TM3-Pri-2U's connectors are identical.

**It is recommended to use the USB connection cable and USB mains adapter included in the package!**



# Specifications

## System

### General

Power requirements:	+5 V DC via USB Micro B connector
Current drain:	400 mA nominal, power-up current is much higher
Display:	Capacitive 4.3" touch screen (272 x 480 pixel)
Connectors:	1 x USB Micro-B; USB 2.0 Full Speed connector for data exchange between computer applications and TM3-Primus, and for power supply via computer or external mains adapter
	2 x RCA-F, analog in (unbalanced, adjustable)
	1 x RCA-F, S/PDIF in (unbalanced)
	1 x RCA-F, S/PDIF out (unbalanced)
Dimensions (W x H x D):	Table-top TM3-Primus: 82.5 x 138 x 50 mm Panel-mount TM3-Pri-2U: 82 x 160 x 29.7 mm
Weight:	approx. 320 g w/o mains adapter
Operating temperature:	+5° to +40° C

### Functions

- Operation with one finger (touch sensitive display)
- Optimized screen layout with selectable instruments
- Multiformat PPM/TruePeak for 2-ch. Stereo (analog, digital, PC audio via USB) and 5.1 Surround signals (PC audio via USB)
- Loudness acc. to ITU-R BS.1770-4/1771-1, EBU R128, ATSC A/85, ARIB, OP-59, AGCOM, CALM Act
- Loudness Chart instrument
- Loudness Range instrument (Magic LRA)
- Moving Coil (BR, VU, BBC mode)
- Stereo Correlator
- 1/3-octave spectrum analyzer (RTA)
- 2-channel Audio Vectorscope
- Monitoring (with onscreen level fader)
- Numerical displays
- USB hybrid function: Simultaneous monitoring and metering, and additional remote control of Start/Stop/Reset function with RTW USB Connect software (PlugIn, Stand-alone)

### Analog Inputs

Inputs:	2 analog inputs, 2 x RCA-F connectors
Input sensitivity:	-22 dBu (61 mV) to +24 dBu (12.28 V), adjustable via potentiometer (see note below!)
Input calibration RTW:	<ul style="list-style-type: none"><li>▪ DIN5: 0 dB reading at +6 dBu (1.55 V)</li><li>▪ BR IIa: "6" reading at +8 dBu (1.946 V) (UK)</li><li>▪ VU: 0 dB reading at +4 dBu (1.228 V) (US)</li></ul>
Reference Levels:	<ul style="list-style-type: none"><li>▪ for analog scales: additionally adjustable in software in steps of 0.1 dB</li><li>▪ for digital scales: relation of dBu to 0 dBFS, adjustable in software in steps of 0.1 dB Example: +6 dBu reads -9 dBFS on TP60 scale with +15 dBu/0 dBFS reference setting</li></ul>
Impedance:	> 10 kΩ



**NOTE** – Please read the manual before adjustment changes are performed. The unit has been calibrated at RTW. All above mentioned analog references will change, when modifying the input sensitivity.

### Digital Inputs/Outputs

	1 digital S/PDIF input, RCA-F, unbalanced, permanently terminated with 75 Ω
	1 digital S/PDIF output, RCA-F
Sampling rates:	28 to 104 kHz, synchronisation to digital input signal

### USB Audio Input

(requires USB driver to be installed on Windows® systems, see Accessory)

Inputs:	Readout and processing of first two USB audio data streams
Modes:	2-ch. Stereo, 5.1 Surround
Sampling rates:	28 to 104 kHz, synchronisation to input signal, internal A/D sample rate @ 48 kHz w/o external digital signal present
Output:	via S/PDIF output connector <ul style="list-style-type: none"><li>▪ decoded, unchanged USB audio input signal</li><li>▪ decoded with or w/o onscreen level fader controlled USB audio input signal, if Monitoring function is activated</li></ul>



## Specifications (continued)

### TP/PPM Bargraph

Description: PPM instrument displaying Peakmeter or TruePeak Meter bargraphs with analog or digital scales and numerical display.

#### PPM instrument

Input sources: analog, digital, USB audio signals

Peakmeter:

- analog, digital: 2-ch. Stereo
- USB: 2-ch. Stereo, 5.1 Surround

Display:

- Bargraph with fixed colors:
  - yellow: normal
  - red: headroom
- Numerical value on top of the bargraph

#### Analog Peakmeter

Analog scales:

- DIN5: +5 .. -50 dB
- TP60: +3 .. -60 dB
- Nordic: +12 .. -42 dB
- BR IIa: 7 .. 1 (British)
- SMPTE24: +24 .. -30
- NHK

Headroom: beginning (turning red) at:

- 0 dB on DIN5 scale
- 9 dBTP on TP60 scale
- +6 dB on Nordic scale
- "6" on BR IIa scale
- +6 dB on SMPTE24 scale
- 0 dB on NHK scale

Integration time: acc. to standard: Sample (TP60), 20 ms (BR IIa), 10 ms (all others)

#### Digital Peak-/TruePeakmeter

Word width: 24 bit

Digital scales:

- TP60: +3 .. -60 dB
- Dig60: 0 .. -60 dB
- Nordic: +12 .. -42 dB
- BR IIa: 7 .. 1 (British)
- VU

Headroom: -9 dBFS, beginning (turning red) at:

- 9 dBTP on TP60 scale
- 9 dBFS on Dig60 scale
- +6 dB on Nordic scale
- "6" on BR IIa scale

Integration time (Attack): acc. to standard: Sample (Dig60), 4x over sample (TP60), 10 ms (Nordic), 20 ms (BR IIa)

### MC - Moving Coil

Description: Moving Coil instrument for the display of needle instruments for 2-channel Stereo with different modes and scales.

#### Moving Coil Instrument

Modes: PPM (BR IIa), VU, PPM (BR IIa) + Loudness (L/R + I)

#### PPM Mode

- Ch. arrangement: Stereo horizontal, Stereo vertical  
 - Scale: BR IIa: 7..1  
 - Integration time: 20 ms

#### VU Mode

- Ch. arrangement: Stereo horizontal, Stereo vertical  
 - Scale analog: VU (-20 to +3 dB)  
 - Scale digital: VU Digital (-20 to +3 dB)  
 - Lead: 0 dB, adjustable from 0 to 10 dB in steps of 1 dB

#### PPM + Loudness Mode

- Ch. arrangement: Dual-PPM with additional Loudness display (BBC) for I in one instrument  
 - Scales:

- PPM: see above
- Loudness: +9 to -9 LU fixed (mid of scale corresponds to Target Level)

### Loudness Bar/Numeric instrument

Description: Loudness Sum and Loudness Num instruments for displaying the summed loudness values M, S, or I of a loudness measurement acc. to EBU R128, ITU BS.1770-4/1771-1, ARIB, ATSC A/85, OP-59, AGCOM, CALM Act on a bargraph resp. on a numerical display.

#### Common Loudness Parameters

Loudness Sum display: One Loudness bargraph selectable:

- M bargraph (Momentary - summation of momentary loudness values of all channels for a short span of time)
- S bargraph (Short - loudness summation value of a dynamic time frame)
- I-Bargraph (Integrated - long term loudness value infinite or manual control)
- Onscreen keys for measurement operation: Start, Stop, Reset Loudness



## Specifications (continued)

Loudness Num display: M, S, I, TPmax, LRA values, selectable  
Weighting filter: K filter acc. to ITU BS.1770  
Level settings for summation (channel weighting):

- 0.0 dB (L, R, C)
- +1.5 dB (LS, RS)
- Off (LFE)

TruePeak Over Threshold: -1 dBTP; adjustable from 0 to -4 dBTP in steps of 1 dBTP

### EBU R128 Loudness Mode

Target Level: -23 LUFS; adjustable from -10 to -30 LUFS in steps of 0.5 LUFS  
Scale: EBU+9: +9 .. -18 LU (Loudness Units)  
M Integration time: 400 ms (SQR)  
S Integration Time: 3 s  
I Silence Gate: -70.0 LUFS  
I Relative Gate: -10.0 LU  
I Tolerance Range: ±1 LU  
Over Sensitivity: -1 dBFS  
Over hold time: 1 s

### ITU BS.1771 Loudness Mode

Target Level: -24 LKFS; adjustable from -10 to -30 LKFS in steps of 0.5 LKFS  
Scale: ITU+9: +9 .. -18 LU (Loudness Units)  
M Integration time: 400 ms (SQR)  
S Integration Time: 3 s  
I Silence Gate: -70.0 LKFS  
I Relative Gate: -10.0 LU  
I Tolerance Range: ±2 LU  
Over Sensitivity: -2 dBFS  
Over hold time: 1 s

### ATSC A/85 Loudness Mode

Target Level: -24 LKFS; adjustable from -10 to -30 LKFS in steps of 0.5 LKFS  
Scale: ATSC0: 0 .. -60 LKFS  
M Integration time: 400 ms (SQR)  
S Integration Time: 3 s  
I Silence Gate: -70.0 LKFS  
I Relative Gate: -10.0 LU  
I Tolerance Range: ±2 LU  
Over Sensitivity: -2 dBFS  
Over hold time: 1 s

### ARIB Loudness Mode

Target Level: -24 LKFS; adjustable from -10 to -30 LKFS in steps of 0.5 LKFS  
Scale: ATSC0: 0 .. -60 LKFS  
M Integration time: 400 ms (SQR)  
S Integration Time: 3 s  
I Silence Gate: -70.0 LKFS  
I Relative Gate: -10.0 LU  
I Tolerance Range: ±0 LU  
Over Sensitivity: -1 dBFS  
Over hold time: 1 s

### OP-59 Loudness Mode

Target Level: -24 LKFS; adjustable from -10 to -30 LKFS in steps of 0.5 LKFS  
Scale: ATSC0: 0 .. -60 LKFS  
M Integration time: 400 ms (SQR)  
S Integration Time: 3 s  
I Silence Gate: -70.0 LKFS  
I Relative Gate: -10.0 LU  
I Tolerance Range: ±2 LU  
Over Sensitivity: -2 dBFS  
Over hold time: 1 s

### AGCOM Loudness Mode

Target Level: -24 LKFS; adjustable from -10 to -30 LKFS in steps of 0.5 LKFS  
Scale: ATSC0: 0 .. -60 LKFS  
M Integration time: 400 ms (SQR)  
S Integration Time: 3 s  
I Silence Gate: -70.0 LKFS  
I Relative Gate: -8.0 LU  
I Tolerance Range: ±0.5 LU  
Over Sensitivity: -2 dBFS  
Over hold time: 1 s

### CALM Loudness Mode

Target Level: -24 LKFS; adjustable from -10 to -30 LKFS in steps of 0.5 LKFS  
Scale: ATSC0: 0 .. -60 LKFS  
M Integration time: 400 ms (SQR)  
S Integration Time: 3 s  
I Silence Gate: -70.0 LKFS  
I Relative Gate: -10.0 LU  
I Tolerance Range: ±2 LU  
Over Sensitivity: -2 dBFS  
Over hold time: 1 s



## Specifications (continued)

### Magic LRA

Description: Loudness Range instrument in MagicLRA mode for a graphical representation of loudness variances.

#### Loudness Range Instrument (LRA)

Display: Graphical display of the Loudness Range  
 Mode: MagicLRA: dynamic bargraph spreading around a zero-point, changing its color when passing the preset ranges

Scale range: -10 LU to +10 LU  
 LRA low range: 5 LU  
 Comfort zone: 10 LU  
 LRA high range: outside the comfort zone  
 Color: green, blended in 3 steps from dark to light acc. to low range, comfort zone, high range

### Chart

Description: Loudness Chart instrument for displaying and analyzing the course over time of a loudness measurement directly on the display.

#### Loudness Chart Instrument

Functions:

- Coordinate system displaying a graph with the course over time of one of the measured values TP, M, S, or I
- Relative Gate view switchable
- Adjustable time ranges
- Vertical Integrated bargraph switchable
- Adjustable tolerance levels

Display:

- Course over time of the selected value with color filling or as line
- Tolerance Marker
- Position of the Relative Gate (doubled horizontal line)
- Vertical I bargraph

Colors:

- Fill: Adoption of the corresponding colors of the Loudness Sum instrument
- Line: cyan (M), light red (S), green (I), yellow (TP)
- Tolerance Marker: coordinate system turns to light grey except the corridor defined by the tolerance settings
- Relative Gate: white

Time range presets: 1 m; 1 m, 5 m, 1 h selectable  
 Time range select: via preset or onscreen during normal operation  
 Lower tolerance: -0.0 LU; tolerance below the Target Level, adjustable from 0 to -6 LU in steps of 0.5 LU  
 Upper tolerance: 0.0 LU; tolerance above the Target Level, adjustable from 0 to 6 LU in steps of 0.5 LU

### VSC - Vectorscope

Description: 2-ch. Audio Vectorscope for displaying the phase relationship between the channels of a channel pair (Lissajous display).

#### Audio Vectorscope Instrument

Display mode: 2-channel  
 Inputs: L/R  
 AGC: fast  
 Grid: L/R

### RTA

Description: Real Time Spectrum Analyzer instrument for displaying the spectral content of the input channels using 31 filter bands. Highpass filter for High Band (>20 kHz).

#### Real Time Spectrum Analyzer (RTA) Instrument

Functions:

- Peak hold on/off
- Set reference
- Selectable resolution

Input sources: Stereo pairs  
 Frequency range: 20 Hz to 20 kHz, highpass filter for High Band (>20 kHz)  
 Number of bands: 1/3-octave: 31 bands, filter acc. to IEC 225 class 2  
 Weighting filter: Linear  
 Peak hold indicator: 4 s, 2 s, off  
 Measuring range: 45 dB max.  
 Resolution: 3, 6, 9 dB  
 Reference: 0.0 dB; adjustable from 0.0 to 21.0 dB in steps of 1 dB  
 Integration time (ballistics): Fast

### Monitoring

Description: The Monitoring instrument provides a monitoring control function which enables monitoring of displayed audio signals.

#### Monitoring Instrument

Functions:

- Monitor level control with onscreen level fader
- Mute, Dim
- Internal Downmix for multichannel monitoring, audio output of monitoring signals via S/PDIF out connector.

Output: Digital 2-ch. Stereo (S/PDIF out, unbal., RCA-F)



## Specifications (continued)

### Correlator

Description: Stereo Correlator instrument for displaying the phase relationship between the two channels of a stereo signal and thus its mono compatibility.

### Correlator Instrument

Display: Bargraph, additional spot indicator between PPM bargraphs

Scale range: -1 r to 0 to +1 r

Standard color setting: red: -1 r to -0.1 r  
white: 0 r (-0.1 r to +0.1 r)  
green: +0.1 r to +1 r

Attack/release time: 1.0 s/2.5 s

### Items of Delivery

- TM3-Primus:
- Display unit with 4.3" touch screen in a table-top case for 2-channel analog or digital stereo audio signals, or stereo and 5.1 USB audio
  - USB-A to Micro-USB-B connecting cable, 1.5 m length
  - USB mains adapter, manual

**Order no.: TM3-Primus**

- TM3-Pri-2U:
- Display unit with 4.3" touch screen in a panel-mount case for 2-channel analog or digital stereo audio signals, or stereo and 5.1 USB audio for mounting into mounting plates, front panels, or 19" environments
  - USB-A to Micro-USB-B connecting cable, 1.5 m length
  - USB mains adapter, manual

**Order no.: TM3-Pri-2U**

### Accessory

USB-Driver:

USB-Driver-Software to run TM3-Primus in USB audio input mode also on Windows® systems. Installer available for download at Audio Monitors/TM3-Primus section of the download area on our website: <https://www.rtw.com/en/support/manuals-software-downloads.html>

### Option

RTW USB Connect:

Software (plug-in, stand-alone) for simultaneous monitoring of audio data via USB (from DAW or media players/internet) and metering with TM3-Primus. Remote control of Start/Stop/Reset functions. Installer and instructions available free of charge for download from PC Software/RTW USB Connect section of the download area on our website: <https://www.rtw.com/en/support/manuals-software-downloads.html> or from RTW USB Connect product page. (Order no.: SW50300)

# Block Diagram

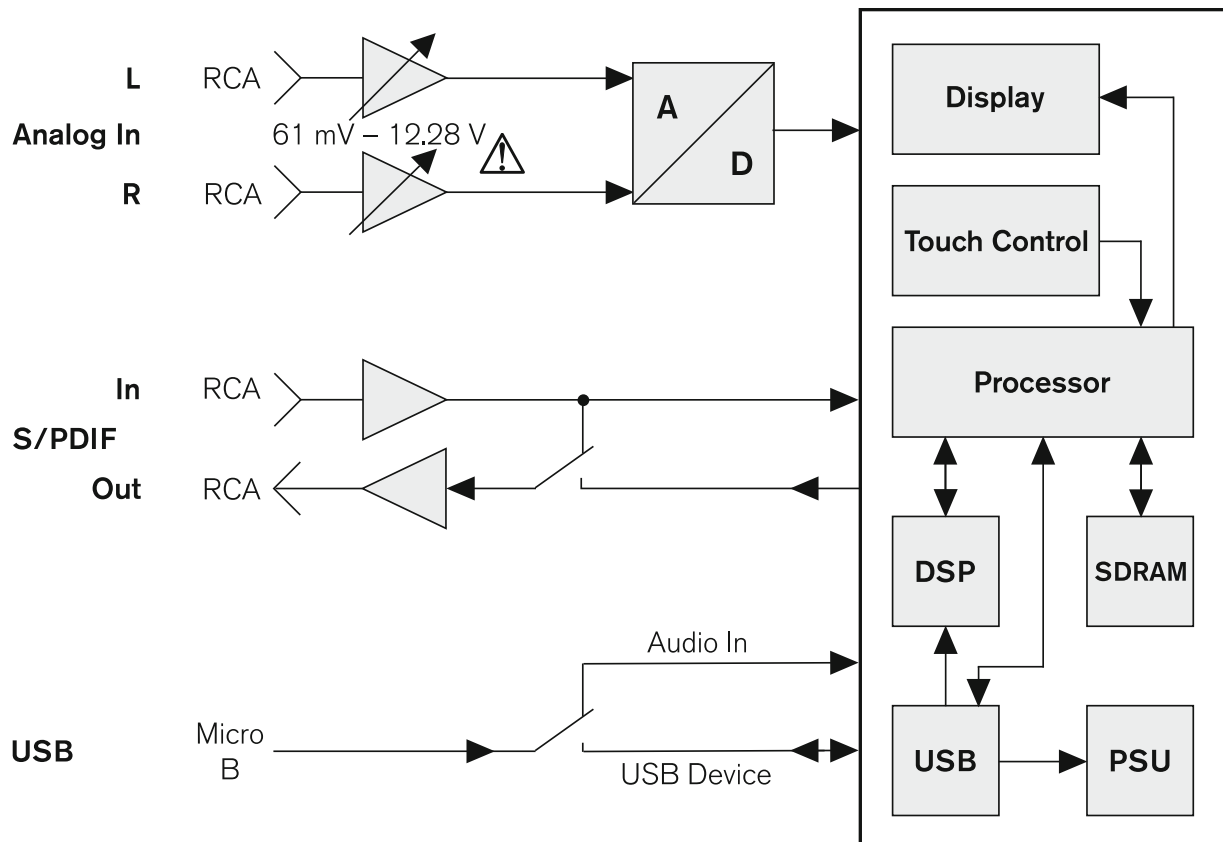

 **Calibrated at RTW. Please refer to manual before readjustment!**

© 03/2017 | Technical changes without prior notice.

RTW US Corp.  
160 Varick St | 3rd Floor | New York NY 10013  
Phone: +1 (646) 458 1423  
ussales@rtw.com | www.rtw.com

**RTW**  
EYES ON YOUR AUDIO